

Inhoudsopgave

Drijfwerkhuis 04	42
Elecktrisch 01	16
Kappen 04	12
Koppeling 05	28
Schakelpoken 02	70
Stickers 03	134
Stuur & Kabels 06	116
Stuurboom 04	88
Tandwielen 02	54
Type Stickers 00	136
Wielas 01	60
Wielen & Banden 03	126
Parts Index	138

Code	Description	Notes
01A_0_12068	BODYGUARD	Version: MC 320, MC 330
01A_1_12095	BODYGUARD	
01A_2_12123	ENGINE PROTECTIONS (310-320-330)	
01A_3_12154	ENGINE PROTECTIONS (310-320-330)	
01A_4_24894	ENGINE PROTECTIONS (310-320-330)	
002_0_10478	002_00 - ELECTRIC STARTER	
002_1_10500	002_01 - ELECTRIC STARTER	
003_0_10557	003_00 - SELF-VENTILATING CONE CLUTCH	
003_1_10576	003_01 - SELF-VENTILATING CONE CLUTCH	
003_2_10596	003_02 - SELF-VENTILATING CONE CLUTCH	
003_3_25078	003_03 - CLUTCH	Version: MC 346, MC 340
003_4_27606	003_04 - SELF-VENTILATING CONE CLUTCH	
003_5_33490	003_05 - CLUTCH	
004_0_10617	004_00 - GEARBOX	
004_1_10650	004_01 - GEARBOX	
004_2_10685	004_02 - GEARBOX	
004_3_10722	004_03 - GEARBOX	
004_4_25109	004_04 - GEARBOX	Version: MC 340
005_0_10769	005_00 - GEARS (320-330)	
005_1_10807	005_01 - GEARS (320-330)	
005_2_10845	005_02 - GEARS (320-330)	
007_0_10996	007_00 - WHEEL AXLE (320)	
007_1_11010	007_01 - WHEEL AXLE (320-310)	
010_0_11134	010_00 - STEERING COLUMN	
010_1_11182	010_01 - CONTROLS (320-330)	Version: MC 320, MC 330
010_2_11218	A010_02 - CONTROLS (320-330)	
10A_0_12219	STEERING COLUMN (320-330)	Version: MC 330, MC 320
10A_1_12244	STEERING COLUMN (310-320-330)	
10A_2_12281	STEERING COLUMN (310-320-330)	
10A_3_12322	STEERING COLUMN (310-320-330)	
10A_4_63871	STEERING COLUMN (310-320-330)	
012_0_11498	012_00 - HANDLEBAR (320-330)	
012_1_11547	012_01 - HANDLEBAR (320-330)	Version: MC 320, MC 330
012_2_11597	012_02 - HANDLEBAR (320-330)	

Code	Description	Notes
012_3_11651	012_03 - HANDLEBAR (320-330)	
012_4_25381	012_04 - HANDLEBAR (320-330)	
012_5_32832	012_05 - HANDLEBAR (320-330)	
012_6_64016	012_06 - HANDLEBAR	
015_0_11945	015_00 - WHEELS	
015_1_11971	015_01 - WHEELS	
015_2_11997	015_02 - WHEELS	
015_3_64117	015_03 - WHEELS	
016_0_12023	016_00 - STICKERS	
016_1_12046	016_01 - STICKERS	
016_2_25498	016_02 - STICKERS	
016_3_32939	016_03 - STICKERS	
017_0_25512	017_00 - STICKERS	

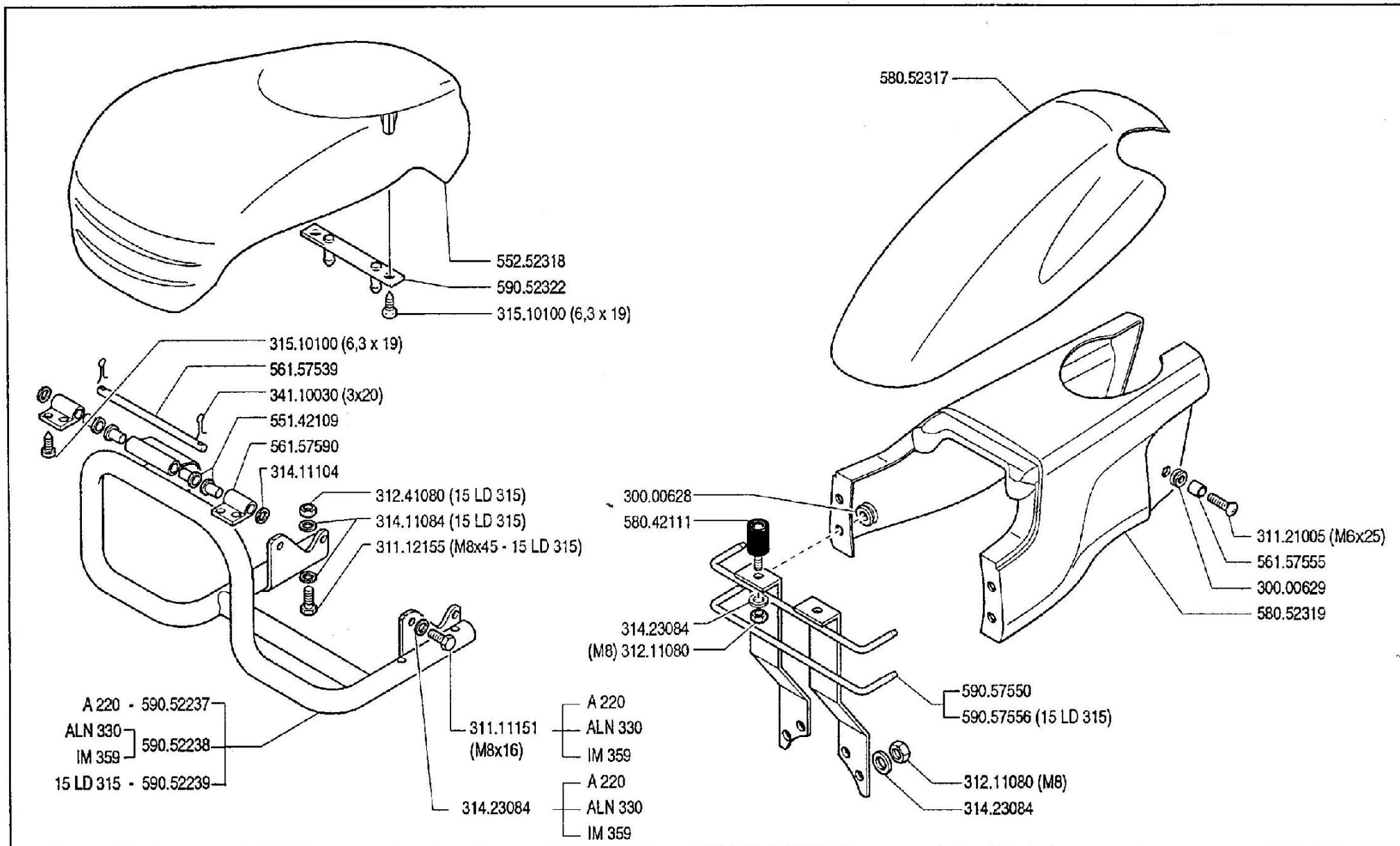

FERRARI

300 serie **95**

CARROZZERIA (320 - 330)

CARROGERÍA
CAROSSERIE

BODY
KAROSSERIE

DALLA MACCHINA
DE LA MAQUINA
DE LA MACHINE
FROM THE MACHINE
AB DER MASCHINE

★ N.

01/A/00

202978 (330)

112717 (320)

11.1996

Pos.	Code	Q.ty	Description	Notes
30000628	30000628	0	CABLE GLAND 90/200/30	
30000629	30000629	0	CABLE GLAND 80/110/30	
31111151	31111151	0	SCREW TE M8X16 UNI 5739 8G	
31112155	31112155	0	SCREW TE M8X45 UNI 5739 8G	
31121005	31121005	0	SCREW TBCEI FLANG. M6X25	
31211080	31211080	0	NUT M8	
31241080	31241080	0	HEXAGON SELFLOCK NUT M8	
31411084	31411084	0	WASHER 8,4x17	
31411104	31411104	0	WASHER 10,5x18	
31423084	31423084	0	SPRING WASHER 8,4	
31510100	31510100	0	RIBBED SCREW 6,3X19 UNI 6950	
34110030	34110030	0	SPLIT PIN	
55142109	55142109	0	BUSHING	
55252318	55252318	0	ENGINE HOOD	
56157539	56157539	0	PIN	
56157555	56157555	0	TUBE	
56157590	56157590	0	HOOD HINGE	
58042111	58042111	0	STOPPER	
58052317	58052317	0	GUARD	
58052319	58052319	0	GUARD	
59052237	59052237	0	COMPLETE BUMPERS	
59052238	59052238	0	COMPLETE BUMPERS	
59052239	59052239	0	COMPLETE BUMPERS	
59052322	59052322	0	SUPPORT	
59057550	59057550	0	SUPPORT	
59057556	59057556	0	SUPPORT	

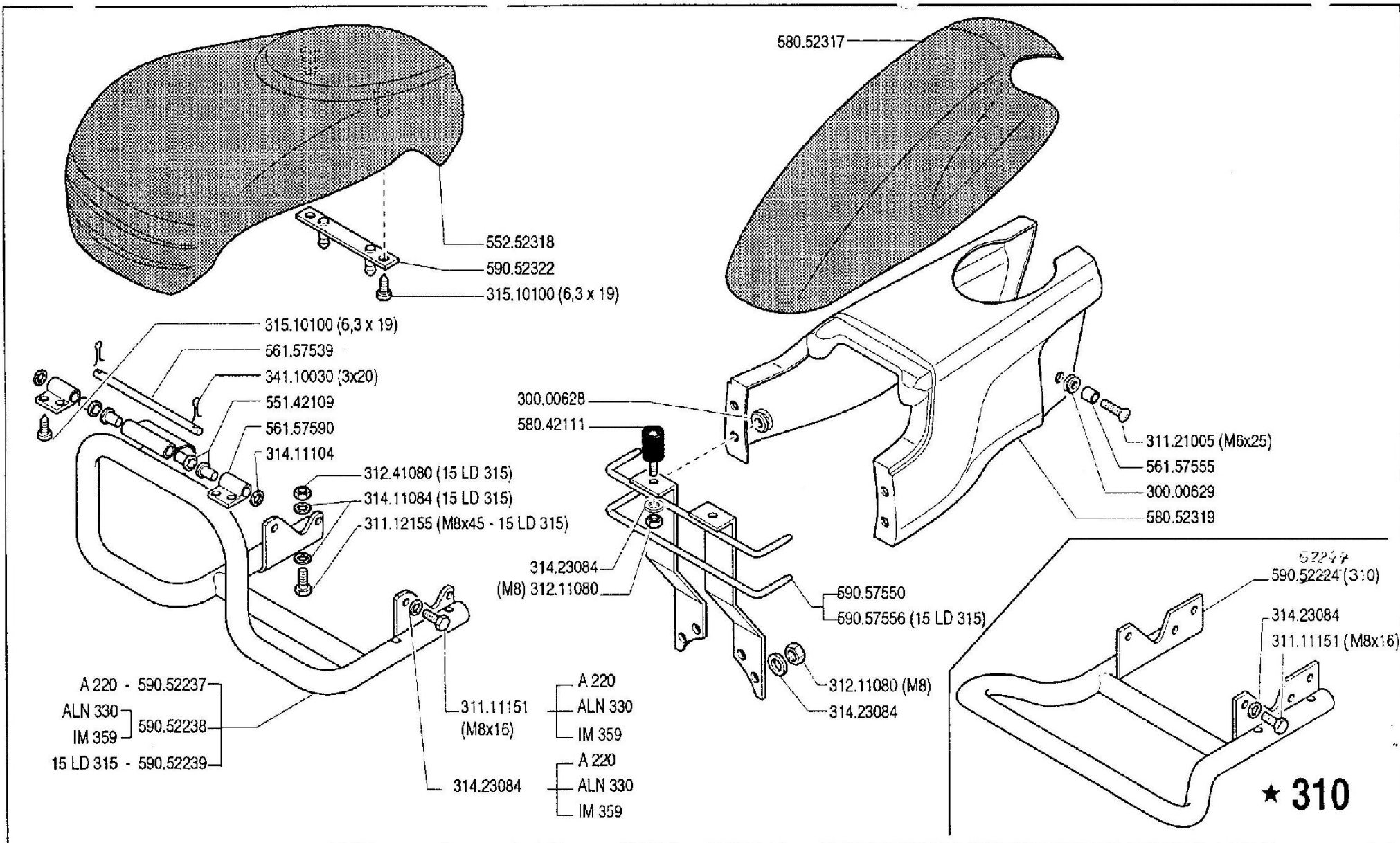

FERRARI

300 serie **95**

CARROZZERIA (310 - 320 - 330)

CARROCERIA
CARROSSERIE

BODY
KAROSSERIE

DALLA MACCHINA
DE LA MAQUINA
DE LA MACHINE
FROM THE MACHINE
AB DER MASCHINE

AGGIORNAMENTO
REVISION
MISE A JOUR
APLAZAMIENTO
ANPASSUNG

01 A 01
9/1997

★ N.

Pos.	Code	Q.ty	Description	Notes
30000628	30000628	0	CABLE GLAND 90/200/30	
30000629	30000629	0	CABLE GLAND 80/110/30	
31111151	31111151	0	SCREW TE M8X16 UNI 5739 8G	
31112155	31112155	0	SCREW TE M8X45 UNI 5739 8G	
31121005	31121005	0	SCREW TBCEI FLANG. M6X25	
31211080	31211080	0	NUT M8	
31241080	31241080	0	HEXAGON SELFLOCK NUT M8	
31411084	31411084	0	WASHER 8,4x17	
31411104	31411104	0	WASHER 10,5x18	
31423084	31423084	0	SPRING WASHER 8,4	
31510100	31510100	0	RIBBED SCREW 6,3X19 UNI 6950	
34110030	34110030	0	SPLIT PIN	
55142109	55142109	0	BUSHING	
55252318	55252318	0	ENGINE HOOD	
56157539	56157539	0	PIN	
56157555	56157555	0	TUBE	
56157590	56157590	0	HOOD HINGE	
58042111	58042111	0	STOPPER	
58052317	58052317	0	GUARD	
58052319	58052319	0	GUARD	
59052237	59052237	0	COMPLETE BUMPERS	
59052238	59052238	0	COMPLETE BUMPERS	
59052239	59052239	0	COMPLETE BUMPERS	
59052244	59052244	0	COMPLETE BUMPERS	
59052322	59052322	0	SUPPORT	
59057550	59057550	0	SUPPORT	
59057556	59057556	0	SUPPORT	

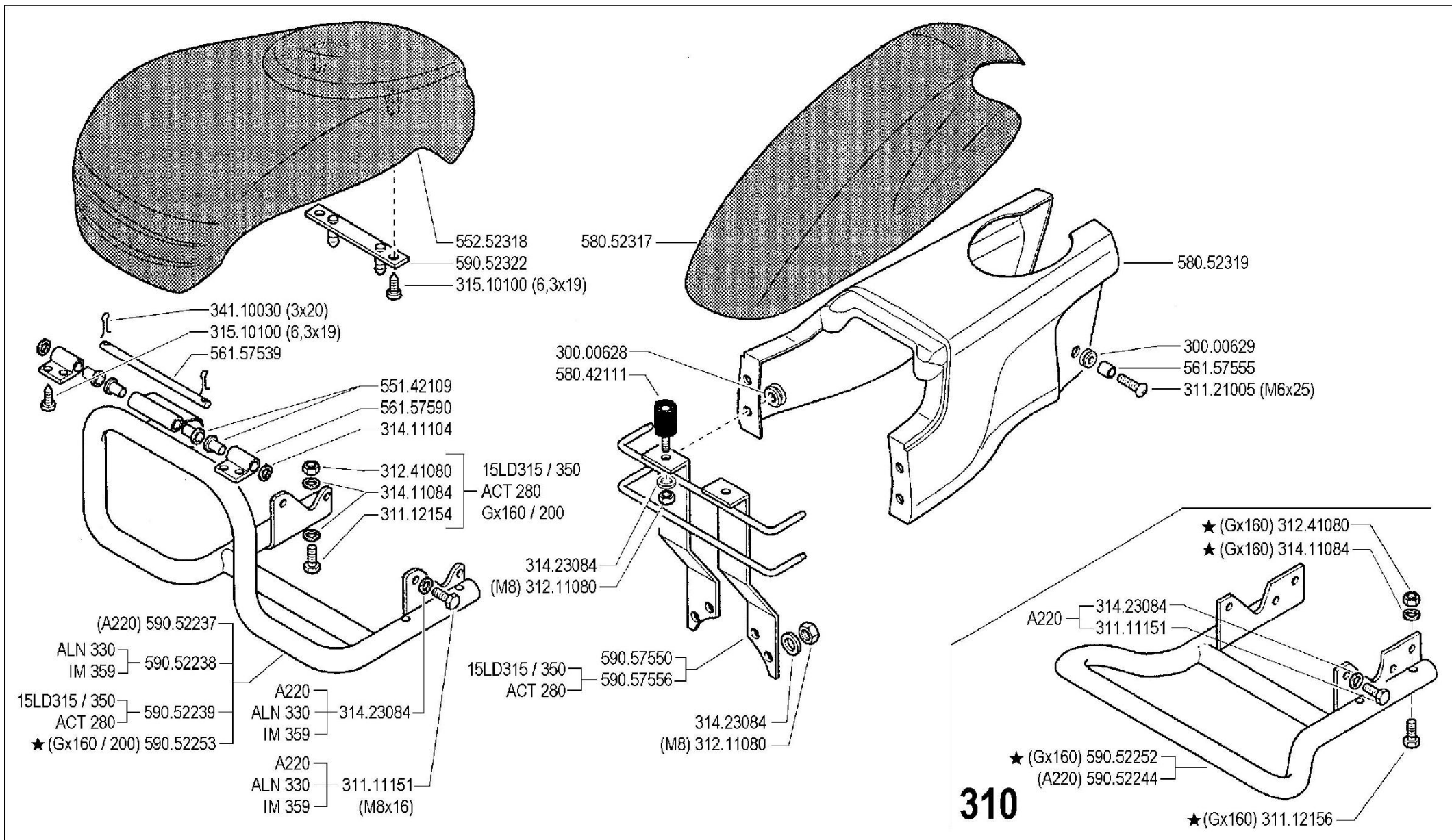

FERRARI

300 serie **95**

PROTEZIONI MOTORE (310-320-330)

ENGINE GUARDS
PROTECCIONES MOTOR

PROTECTIONS MOTEUR
MOTOR SCHUTZ

DALLA MACCHINA
DE LA MAQUINA
DE LA MACHINE
FROM THE MACHINE
AB DER MASCHINE

AGGIORNAMENTO

REVISION

MISE A JOUR

APLAZAMIENTO

ANPASSUNG

01 A 02

1/2000

Mod.

★N.

ZENIT

Pos.	Code	Q.ty	Description	Notes
30000628	30000628	0	CABLE GLAND 90/200/30	
30000629	30000629	0	CABLE GLAND 80/110/30	
31111151	31111151	0	SCREW TE M8X16 UNI 5739 8G	
31112154	31112154	0	SCREW TE M8X40 UNI 5739 8G	
31112156	31112156	0	SCREW TE M8X60 UNI 5739 8G	
31121005	31121005	0	SCREW TBCEI FLANG. M6X25	
31211080	31211080	0	NUT M8	
31241080	31241080	0	HEXAGON SELFLOCK NUT M8	
31411084	31411084	0	WASHER 8,4x17	
31411104	31411104	0	WASHER 10,5x18	
31423084	31423084	0	SPRING WASHER 8,4	
31510100	31510100	0	RIBBED SCREW 6,3X19 UNI 6950	
34110030	34110030	0	SPLIT PIN	
55142109	55142109	0	BUSHING	
55252318	55252318	0	ENGINE HOOD	
56157539	56157539	0	PIN	
56157555	56157555	0	TUBE	
56157590	56157590	0	HOOD HINGE	
58042111	58042111	0	STOPPER	
58052317	58052317	0	GUARD	
58052319	58052319	0	GUARD	
59052237	59052237	0	COMPLETE BUMPERS	
59052238	59052238	0	COMPLETE BUMPERS	
59052239	59052239	0	COMPLETE BUMPERS	
59052244	59052244	0	COMPLETE BUMPERS	
59052252	59052252	0	COMPLETE BUMPERS	
59052253	59052253	0	COMPLETE BUMPERS	
59052322	59052322	0	SUPPORT	
59057550	59057550	0	SUPPORT	
59057556	59057556	0	SUPPORT	

SERIAL

ENGINE PROTECTIONS (310-320-330)

CODE REV

01A_2_12123

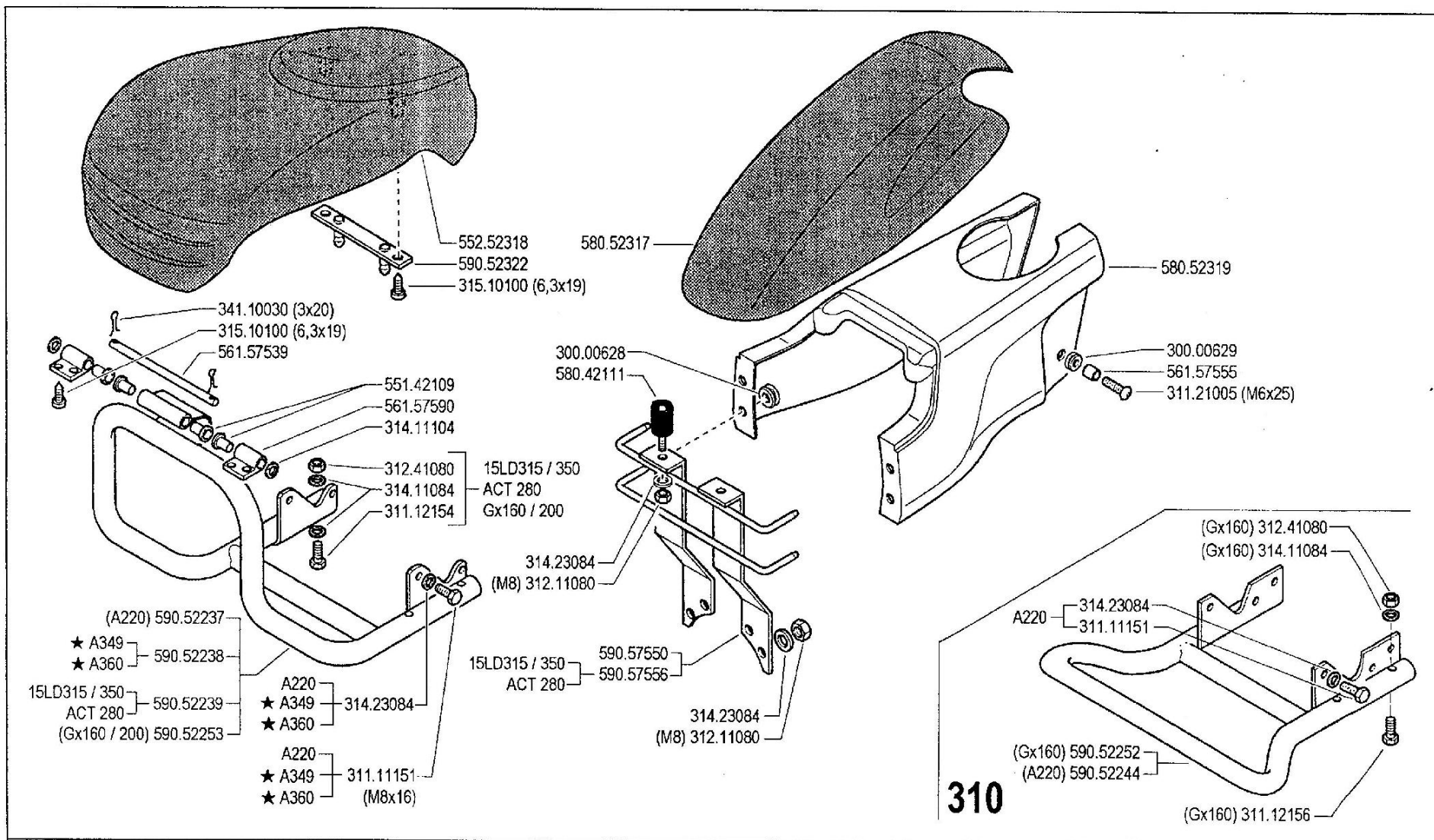

FERRARI

300 serie **95**

PROTEZIONI MOTORE (310-320-330)

ENGINE GUARDS
PROTECCIONES MOTOR

PROTECTIONS MOTEUR
MOTOR SCHUTZ

DALLA MACCHINA
DE LA MAQUINA
DE LA MACHINE
FROM THE MACHINE
AB DER MASCHINE

AGGIORNAMENTO
REVISION
MISE A JOUR
APLAZAMIENTO
ANPASSUNG

★ N.

01 A 3

3/2001

Rev.

ZENNE

Pos.	Code	Q.ty	Description	Notes
30000628	30000628	0	CABLE GLAND 90/200/30	
30000629	30000629	0	CABLE GLAND 80/110/30	
31111151	31111151	0	SCREW TE M8X16 UNI 5739 8G	
31112154	31112154	0	SCREW TE M8X40 UNI 5739 8G	
31112156	31112156	0	SCREW TE M8X60 UNI 5739 8G	
31121005	31121005	0	SCREW TBCEI FLANG. M6X25	
31211080	31211080	0	NUT M8	
31241080	31241080	0	HEXAGON SELFLOCK NUT M8	
31411084	31411084	0	WASHER 8,4x17	
31411104	31411104	0	WASHER 10,5x18	
31423084	31423084	0	SPRING WASHER 8,4	
31510100	31510100	0	RIBBED SCREW 6,3X19 UNI 6950	
34110030	34110030	0	SPLIT PIN	
55142109	55142109	0	BUSHING	
55252318	55252318	0	ENGINE HOOD	
56157539	56157539	0	PIN	
56157555	56157555	0	TUBE	
56157590	56157590	0	HOOD HINGE	
58042111	58042111	0	STOPPER	
58052317	58052317	0	GUARD	
58052319	58052319	0	GUARD	
59052237	59052237	0	COMPLETE BUMPERS	
59052238	59052238	0	COMPLETE BUMPERS	
59052239	59052239	0	COMPLETE BUMPERS	
59052244	59052244	0	COMPLETE BUMPERS	
59052252	59052252	0	COMPLETE BUMPERS	
59052253	59052253	0	COMPLETE BUMPERS	
59052322	59052322	0	SUPPORT	
59057550	59057550	0	SUPPORT	
59057556	59057556	0	SUPPORT	

SERIAL

ENGINE PROTECTIONS (310-320-330)

CODE REV

01A_3_12154

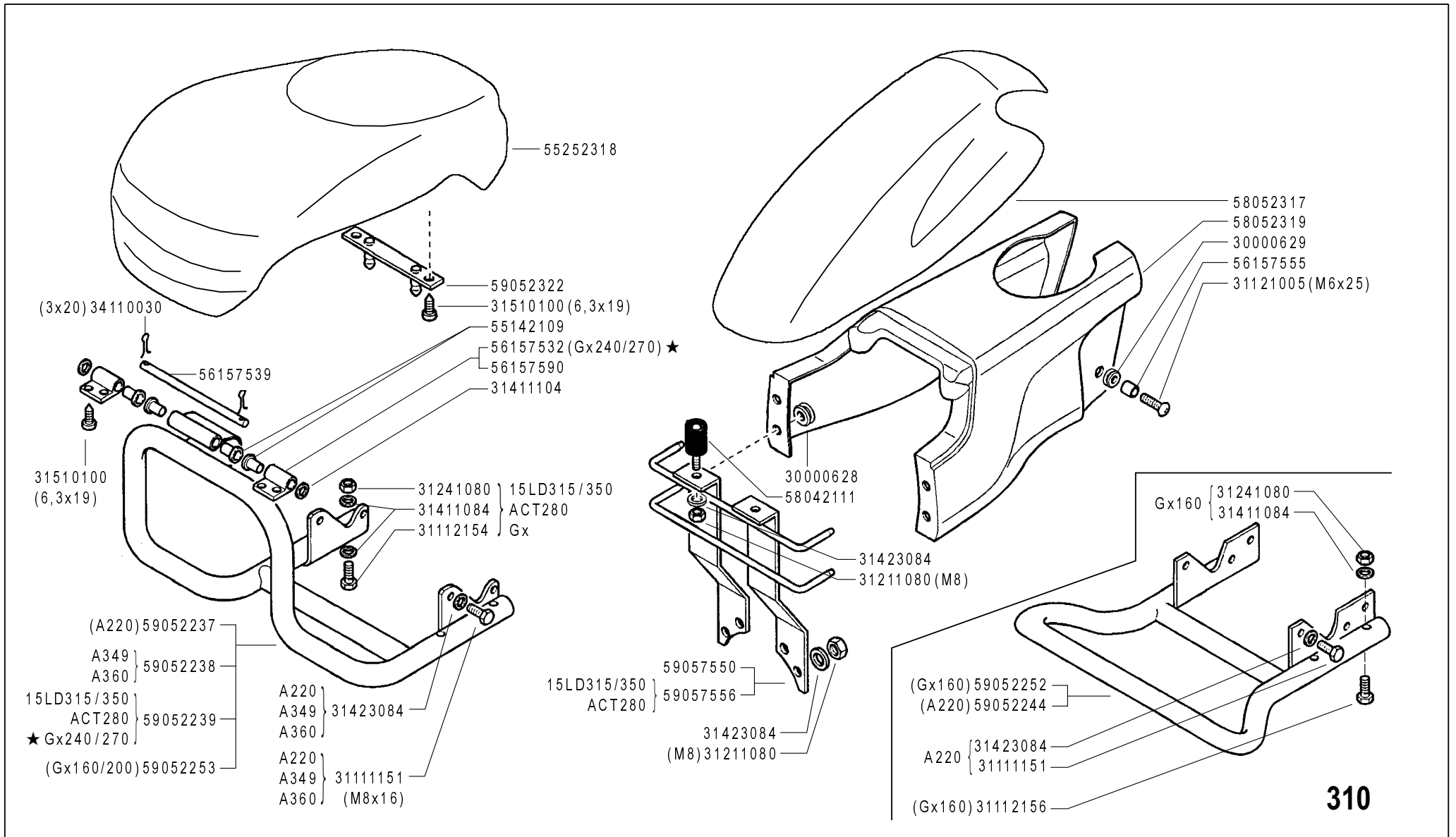

FERRARI

300 serie **95**

PROTEZIONI MOTORE (310-320-330)

ENGINE GUARDS
PROTECCIONES MOTOR

PROTECTIONS MOTEUR
MOTORSCHUTZ

DALLA MACCHINA
DE LA MAQUINA
DE LA MACHINE
FROM THE MACHINE
AB DER MASCHINE

AGGIORNAMENTO
REVISION
MISE A JOUR
APLAZAMIENTO
ANPASSUNG

★N.

01 A 4

02/2006

Rev.

ZENNE

Pos.	Code	Q.ty	Description	Notes
30000628	30000628	0	CABLE GLAND 90/200/30	
30000629	30000629	0	CABLE GLAND 80/110/30	
31111151	31111151	0	SCREW TE M8X16 UNI 5739 8G	
31112154	31112154	0	SCREW TE M8X40 UNI 5739 8G	
31112156	31112156	0	SCREW TE M8X60 UNI 5739 8G	
31121005	31121005	0	SCREW TBCEI FLANG. M6X25	
31211080	31211080	0	NUT M8	
31241080	31241080	0	HEXAGON SELFLOCK NUT M8	
31411084	31411084	0	WASHER 8,4x17	
31411104	31411104	0	WASHER 10,5x18	
31423084	31423084	0	SPRING WASHER 8,4	
31510100	31510100	0	RIBBED SCREW 6,3X19 UNI 6950	
34110030	34110030	0	SPLIT PIN	
55142109	55142109	0	BUSHING	
55252318	55252318	0	ENGINE HOOD	
56157532	56157532	1	HOOD HINGE	
56157539	56157539	0	PIN	
56157555	56157555	0	TUBE	
56157590	56157590	0	HOOD HINGE	
58042111	58042111	0	STOPPER	
58052317	58052317	0	GUARD	
58052319	58052319	0	GUARD	
59052237	59052237	0	COMPLETE BUMPERS	
59052238	59052238	0	COMPLETE BUMPERS	
59052239	59052239	0	COMPLETE BUMPERS	
59052244	59052244	0	COMPLETE BUMPERS	
59052252	59052252	0	COMPLETE BUMPERS	
59052253	59052253	0	COMPLETE BUMPERS	
59052322	59052322	0	SUPPORT	
59057550	59057550	0	SUPPORT	
59057556	59057556	0	SUPPORT	

SERIAL

ENGINE PROTECTIONS (310-320-330)

CODE REV

01A_4_24894

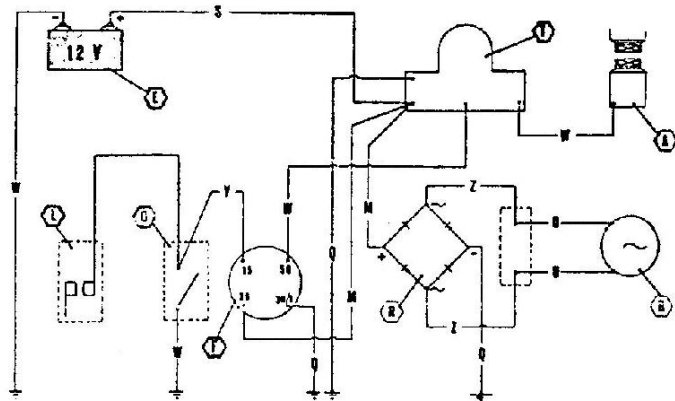

ALN 330
AT 330

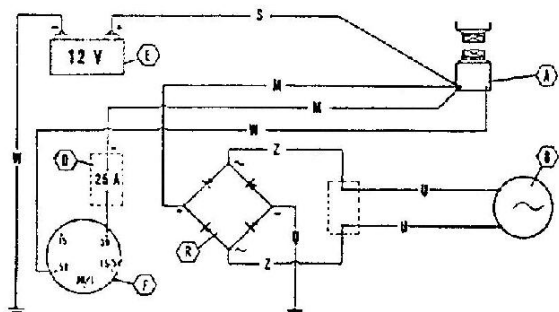

6LD 435

A	B	D	E	F
MOTORE D'AVVIAMENTO STARTER MOT DE ARRANQUE ANLASSMOTOR	GENERATORE DÉMARREUR GENERADOR GENERATOR	FUSIBILI FUSES FUSIBLES	BATTERIA BATTERIE BATERIA BATTERIE	INTERRUPTORE SWITCH INTERLUPTOR SCHALTER

L	O
PURIFICHE POINTS GRAINS PLATINOS KONTAKTSITZE	MOTOR STOP MOTOR STOP MOTOR STOP MOTOR STOP MOTOR STOP

R	Y
INDICAZIONE RECTIFIER REPRESSOR EMERLEADOR BELEH	TELEINTORRE REMOTE CONTROL SWITCH TELEINTORRE Fernschalter

M	N	Q	S	U	V	Z	Y	W
ROSSO RED ROUGE ROJO ROT	VERDE GREEN VERT VERDE GRÜN	GIALLO - VERDE YELLOW - GREEN JAUNE - VERT AMARILLO VERDE GELB - GRÜN	BLU BLUE BLEU AZUL BLAU	GIALLO YELLOW JAUNE AMARILLO GELB	BIANCO WHITE BLANC BLANCO WEISS	MARRONE BROWN MARRON CASTANO BRAUN	GRIGIO GREY GRIS GRIS GRAU	NERO BLACK NOIR NEGRO SCHWARZ

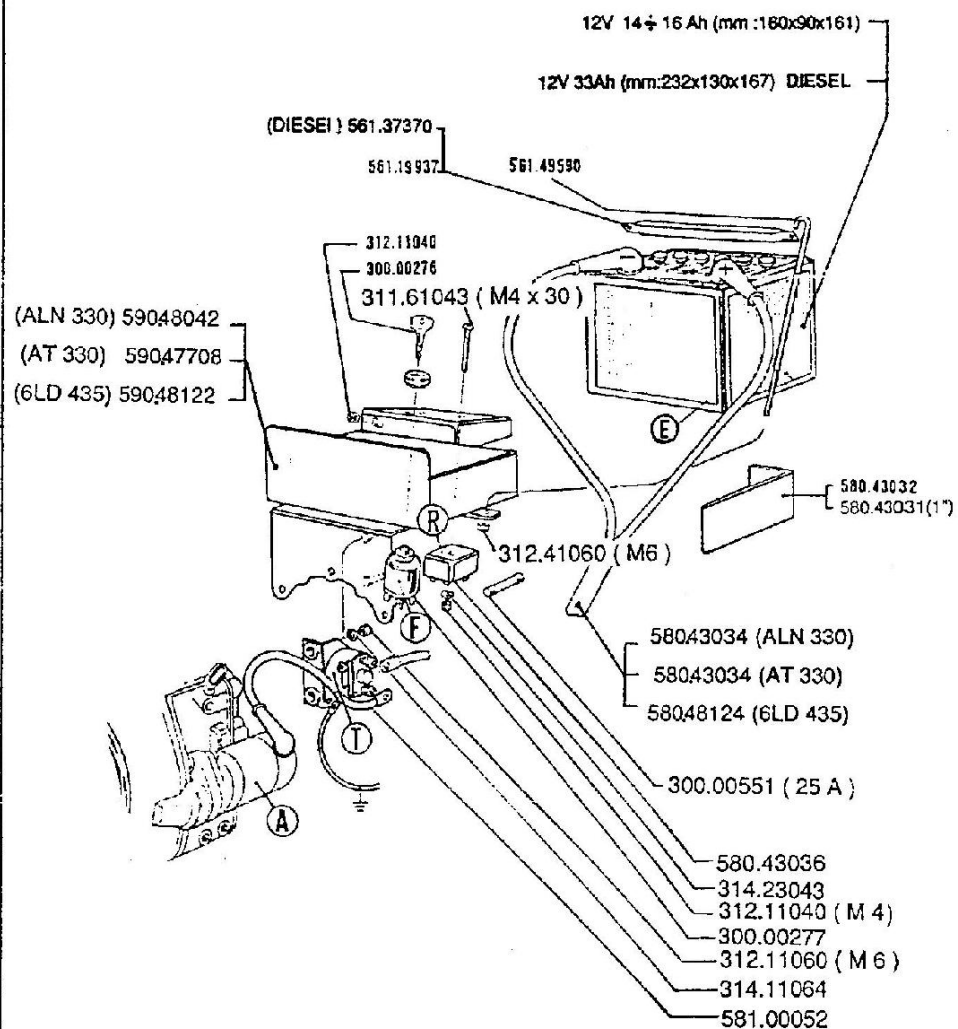

FERRARI

300 serie **95**

AVVIAMENTO ELETTRICO

ARRANQUE ELECTRICO
DÉMARRAGE ÉLECTRIQUE

ELECTRIC STARTER
ELEKTROSTART

DALLA MACCHINA
DE LA MAQUINA
DE LA MACHINE
FROM THE MACHINE
AB DER MASCHINE

N.

02.00

01.06.1995

Pos.	Code	Q.ty	Description	Notes
30000276	30000276	0	KEY	
30000277	30000277	0	SWITCH	
30000551	30000551	0	FUSE/LOCK	
31161043	31161043	0	SCREW TC M4X30 UNI 6107	
31211040	31211040	0	NUT M4	
31211060	31211060	0	HEXAGONAL NUT M8	
31241060	31241060	0	HEXAGON SELFLOCK NUT M6	
31411064	31411064	0	WASHER 6,4x12,5	
31423043	31423043	0	SPRING WASHER 4,3	
56119937	56119937	0	BATTERY SUPPORT	
56137370	56137370	0	BATTERY BRACKET	
56149590	56149590	0	BATTERY BRACKET	
58043031	58043031	0	RUBBER	
58043032	58043032	0	KIT	
58043034	58043034	0	WIRING	
58043036	58043036	0	RECTIFIER	
58048124	58048124	0	WIRING	
58100052	58100052	0	RELAY	
59047708	59047708	0	BATTERY SUPPORT	
59048042	59048042	0	BATTERY SUPPORT	
59048122	59048122	0	BATTERY SUPPORT	

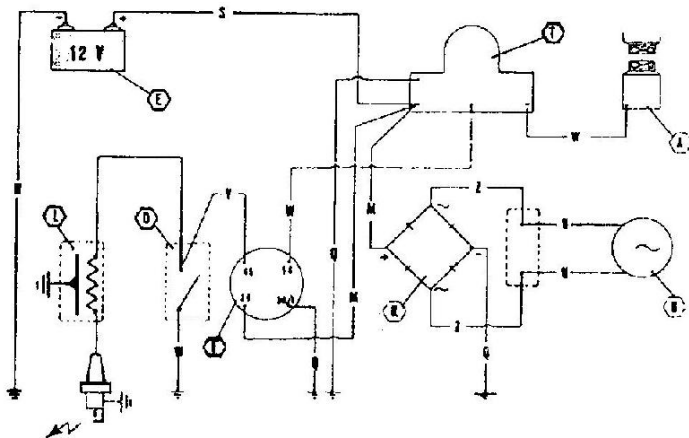

ALN 330
AT 330

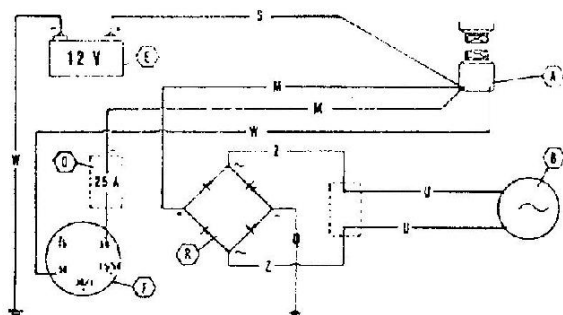

6LD 435

A	B	D	E	F
MOTORINO D'AVVIAMENTO STARTER DE MARCHEUR MOT DE ARRANQUE MILASSMOTOR	GENERATORE GENERATOR GENÉRATEUR GENERADOR GENERATOR	FUSIBILI FUSES FUSIBLES FUSIBLES SCHMELZSICHERHEITEN	BATTERIA BATTERY BATTERIE BATERIA BATTERIE	INTERRUTTORE SWITCH INTERROMPTEUR INTERRUPTOR SCHALTER

★ L	O
BOSINA COIL BOBINE BOBINA SPULE	MOTOR STOP MOTOR STOP MOTOR STOP MOTOR STOP MOTOR STOP

R	T
ANDORIZZATORE RECTIFIER RECTIFIEUR RECTOR REGLER	TELEINTERRUTTORE REMOTE COIL SWITCH TELEINTERRUPTEUR TELEINTERRUPTOR FERNSCHALTER

M	N	Q	S	U	V	Z	Y	W
ROSSO RED ROUGE ROJO ROI	VERDE GREEN VERT VERDE GRÜN	GIALLO VERDE YELLOW-GREEN JAUNE-VERT AMARILLO VERDE GELB GRÜN	BLU BLUE BLEU AZUL BLAU	GIALLO YELLOW JAUNE AMARILLO GELB	BIANCO WHITE BLANC BLANCO WEISS	MARRONE BROWN MARRON CASTAÑO BRAUN	GRIGIO GREY GRIS GRIS GRAU	NERO BLACK NOIR NEGRO SCHWARZ

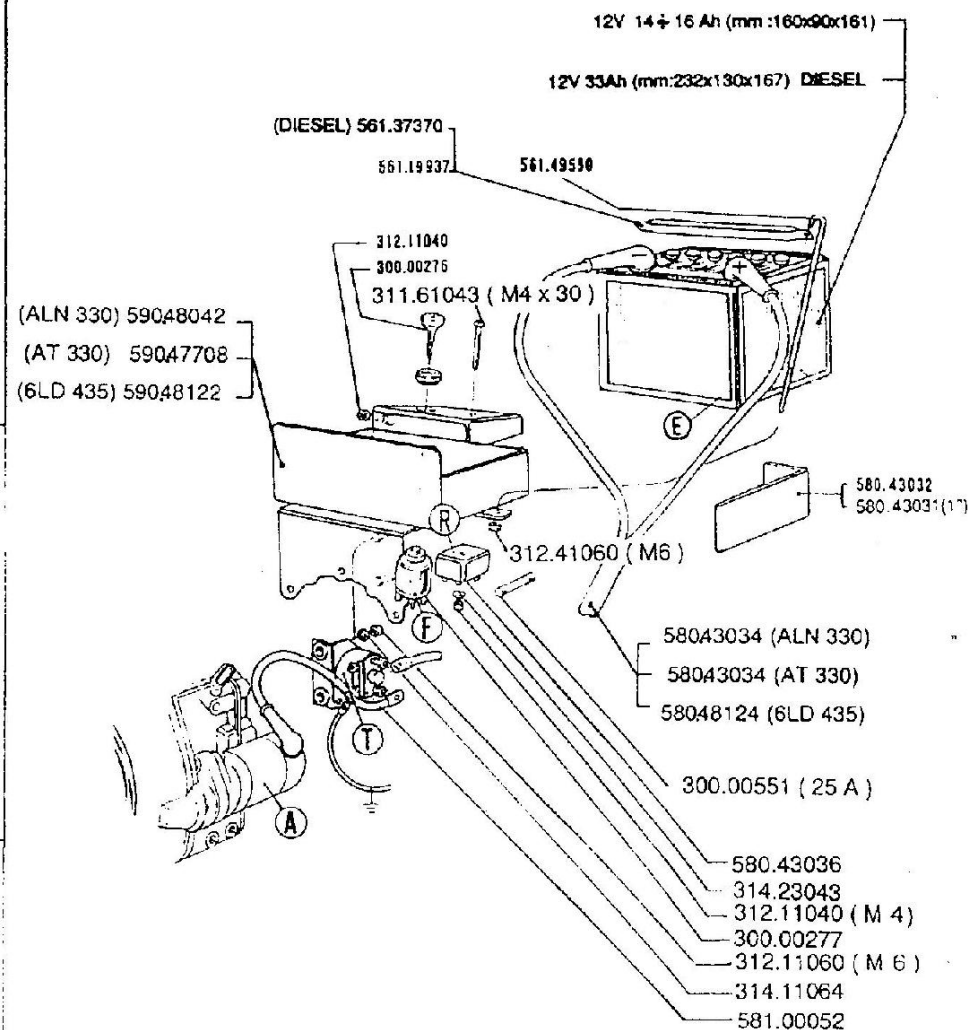

(ALN 330) 59048042
(AT 330) 59047708
(6LD 435) 59048122

12V 14 + 16 Ah (mm:160x90x161)
12V 33Ah (mm:232x130x167) DIESEL

(DIESEL) 561.37370

561.19937

561.49590

312.11040

300.00275

311.61043 (M4 x 30)

E

580.43032

580.43031(17)

312.41060 (M6)

58043034 (ALN 330)

58043034 (AT 330)

58048124 (6LD 435)

300.00551 (25 A)

580.43036

314.23043

312.11040 (M4)

300.00277

312.11060 (M6)

314.11064

581.00052

FERRARI

300 serie **95**

AVVIAMENTO ELETTRICO

ARRANQUE ELECTRICO
DÉMARRAGE ÉLECTRIQUE

ELECTRIC STARTER
ELEKTROSTART

DALLA MACCHINA
DE LA MAQUINA
DE LA MACHINE
FROM THE MACHINE
AB DER MASCHINE

AGGIORNAMENTO

REVISION

MISE A JOUR

APLAZAMIENTO

ANPASSUNG

02.01

9/1997

★ N.

Pos.	Code	Q.ty	Description	Notes
30000276	30000276	0	KEY	
30000277	30000277	0	SWITCH	
30000551	30000551	0	FUSE/LOCK	
31161043	31161043	0	SCREW TC M4X30 UNI 6107	
31211040	31211040	0	NUT M4	
31211060	31211060	0	HEXAGONAL NUT M8	
31241060	31241060	0	HEXAGON SELFLOCK NUT M6	
31411064	31411064	0	WASHER 6,4x12,5	
31423043	31423043	0	SPRING WASHER 4,3	
56119937	56119937	0	BATTERY SUPPORT	
56137370	56137370	0	BATTERY BRACKET	
56149590	56149590	0	BATTERY BRACKET	
58043031	58043031	0	RUBBER	
58043032	58043032	0	KIT	
58043034	58043034	0	WIRING	
58043036	58043036	0	RECTIFIER	
58048124	58048124	0	WIRING	
58100052	58100052	0	RELAY	
59047708	59047708	0	BATTERY SUPPORT	
59048042	59048042	0	BATTERY SUPPORT	
59048122	59048122	0	BATTERY SUPPORT	

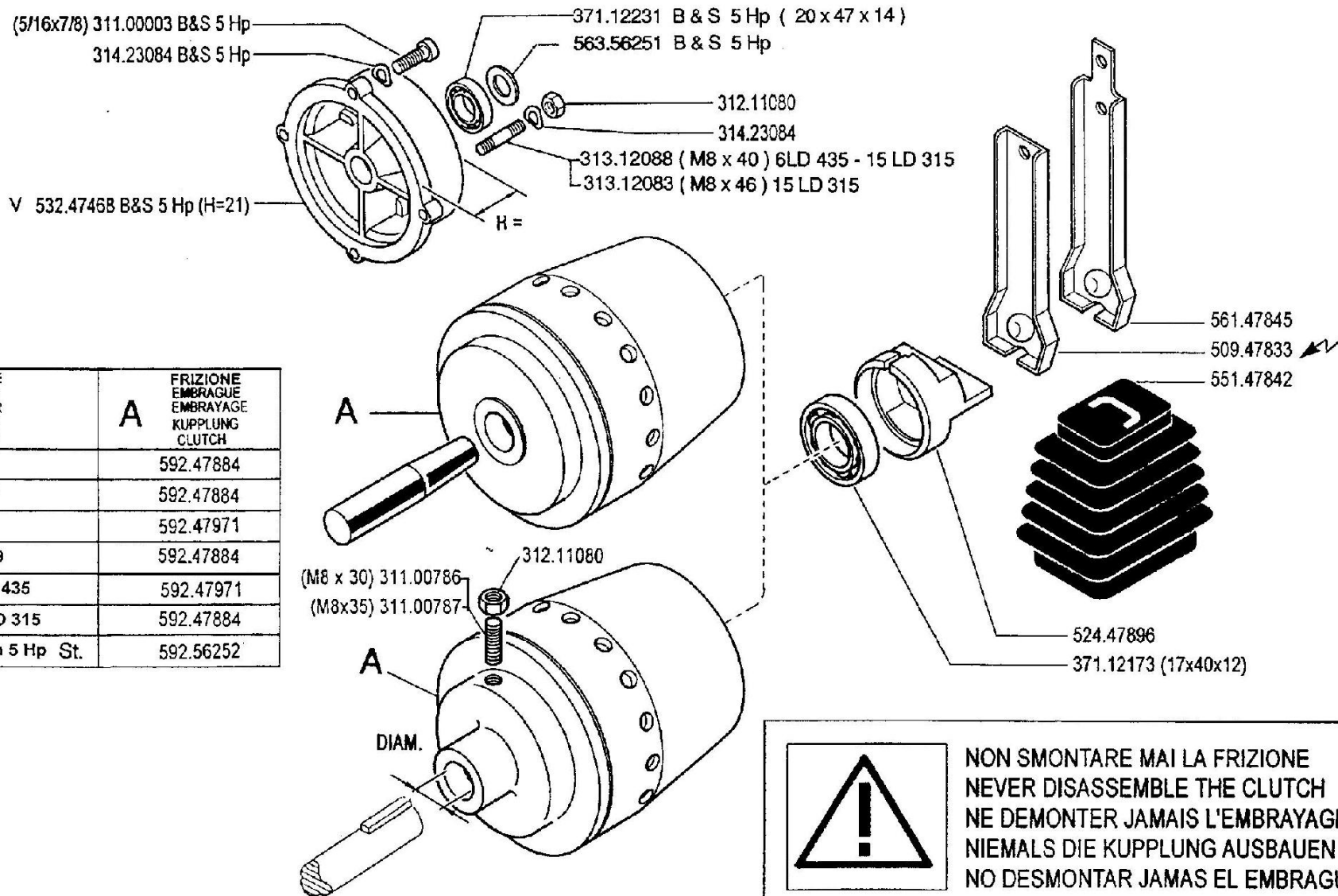

MOTORE ENGINE MOTEUR MOTOR	A	FRIZIONE EMBRAGUE EMBRAYAGE KUPPLUNG CLUTCH
Acme A220		592.47884
Acme ALN 330W		592.47884
Acme AT 330 W		592.47971
Intermotor IM 359		592.47884
Lombardini 6 LD 435		592.47971
Lombardini 15 LD 315		592.47884
Briggs & Stratton 5 Hp St.		592.56252

V = verde - vert - green - grün

FERRARI

300 serie **95**

FRIZIONE A CONO AUTOVENTILANTE

EMBRAGUE
EMBRAYAGE

CLUTCH
KUPPLUNG

DALLA MACCHINA
DE LA MAQUINA
DE LA MACHINE
FROM THE MACHINE
AB DER MASCHINE

N.

03.00

01.06.1995

Pos.	Code	Q.ty	Description	Notes
31100003	31100003	0	SCREW TE 5/16X7/8	
31100786	31100786	0	SCREW STEI M8X30 UNI5923 8G	
31100787	31100787	0	SCREW STEI M8X35 UNI5923 8G	
31211080	31211080	0	NUT M8	
31312083	31312083	0	STUD BOLT M8X46X16X16	
31312088	31312088	0	STUD BOLT M8X40X14X14	
31423084	31423084	0	SPRING WASHER 8,4	
37112173	37112173	0	BEARING	
37112231	37112231	0	BEARING	
50947833	50947833	0	CLUTCH LEVER	
52447896	52447896	0	PRESSURE PLATE	
53247468	53247468	0	FLANGE	
55147842	55147842	0	BELLOWS	
56147845	56147845	0	CLUTCH LEVER	
56356251	56356251	0	SHIM D=19,6	
59247884	59247884	0	CLUTCH ASSY	
59247971	59247971	0	CLUTCH	
59256252	59256252	0	CLUTCH ASSY	

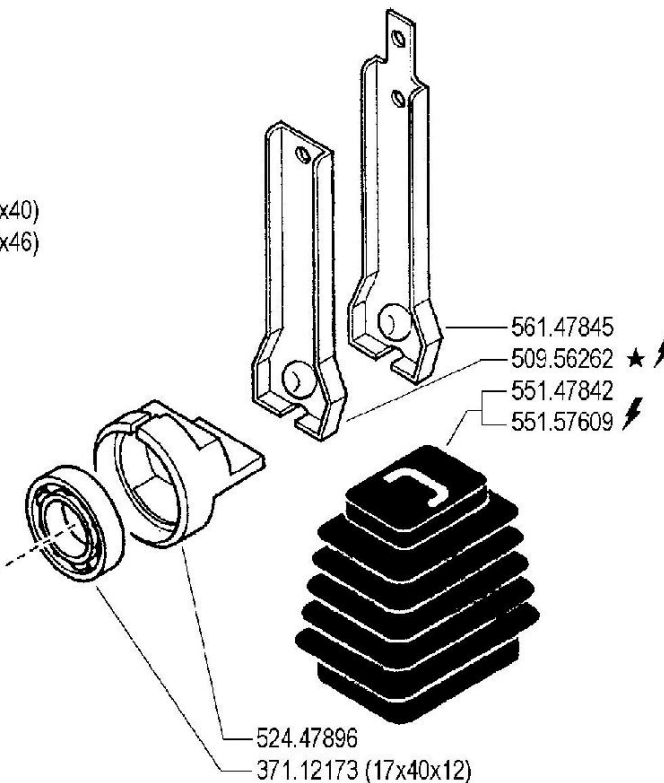
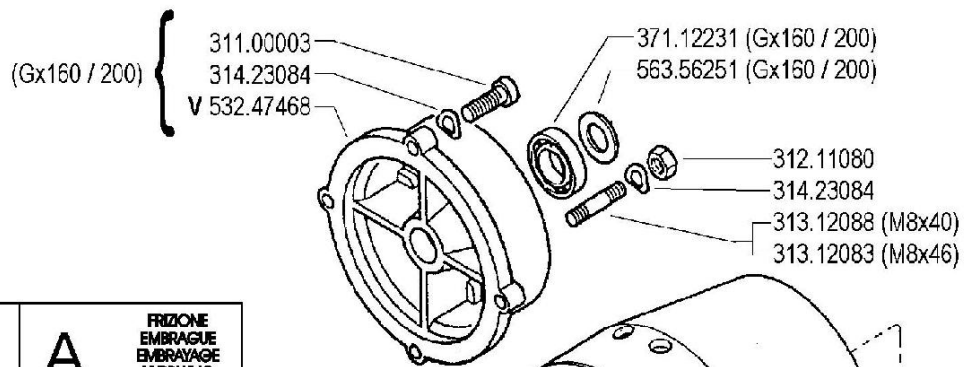

 **NON SMONTARE MAI LA FRIZIONE
NEVER DISASSEMBLE THE CLUTCH
NE DEMONTER JAMAIS L'EMBRAYAGE
NIEMALS DIE KUPPLUNG AUSBAUEN
NO DESMONTAR JAMAS EL FMBRAGUE**

MOTORE ENGINE MOTEUR MOTOR	A	FRIZIONE EMBRAYAGE EMBRAYAGE KUPPLUNG CLUTCH
Acme A 220	592.47884	
Acme ALN 330W - ACT 280 ★	592.47884	
Acme AT 330W - ACT 340 ★	592.47971	
Honda Gx 160 / 200 ★	592.56252	
Intermotor IM 359	592.47884	
Lombardini 6 LD 435	592.47971	
Lombardini 15 LD 315 / 350	592.47884	
Yanmar L100 AE ★	592.47971	

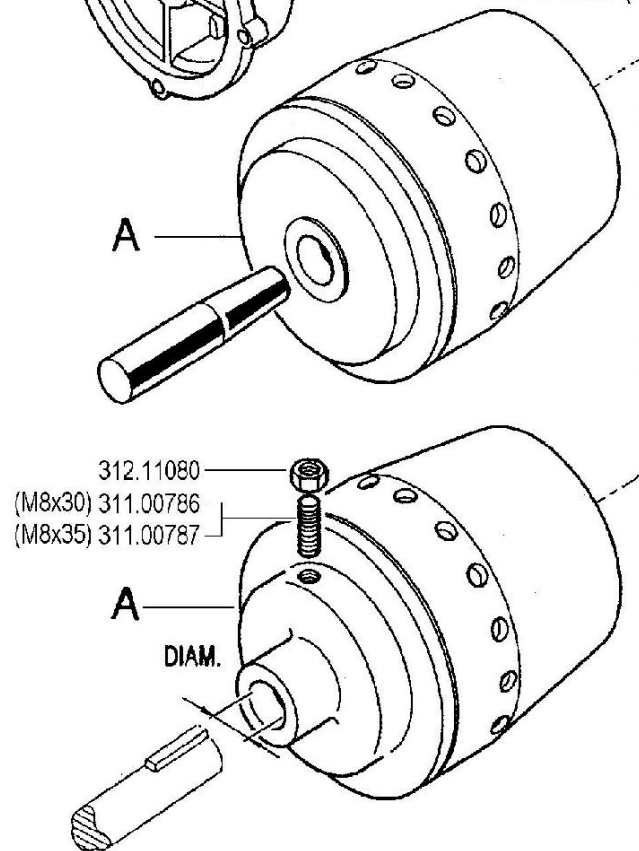

V = verde - green - vert - grün

FERRARI

300 serie 95

FRIZIONE A CONO AUTOVENTILANTE

CLUTCH
EMBRAGUE

EMBRAYAGE
KUPPLUNG

DALLA MACCHINA
DE LA MAQUINA
DE LA MACHINE
FROM THE MACHINE
AB DER MASCHINE

AGGIORNAMENTO

REVISION

MISE A JOUR

APLAZAMIENTO

ANPASSUNG

03

Mod.
01

1/2000

★ N.

Pos.	Code	Q.ty	Description	Notes
31100003	31100003	0	SCREW TE 5/16X7/8	
31100786	31100786	0	SCREW STEI M8X30 UNI5923 8G	
31100787	31100787	0	SCREW STEI M8X35 UNI5923 8G	
31211080	31211080	0	NUT M8	
31312083	31312083	0	STUD BOLT M8X46X16X16	
31312088	31312088	0	STUD BOLT M8X40X14X14	
31423084	31423084	0	SPRING WASHER 8,4	
37112173	37112173	0	BEARING	
37112231	37112231	0	BEARING	
50956262	50956262	0	CLUTCH LEVER	
52447896	52447896	0	PRESSURE PLATE	
53247468	53247468	0	FLANGE	
55147842	55147842	0	BELLOWS	
55157609	55157609	0	BELLOWS	
56147845	56147845	0	CLUTCH LEVER	
56356251	56356251	0	SHIM D=19,6	
59247884	59247884	0	CLUTCH ASSY	
59247971	59247971	0	CLUTCH	
59256252	59256252	0	CLUTCH ASSY	

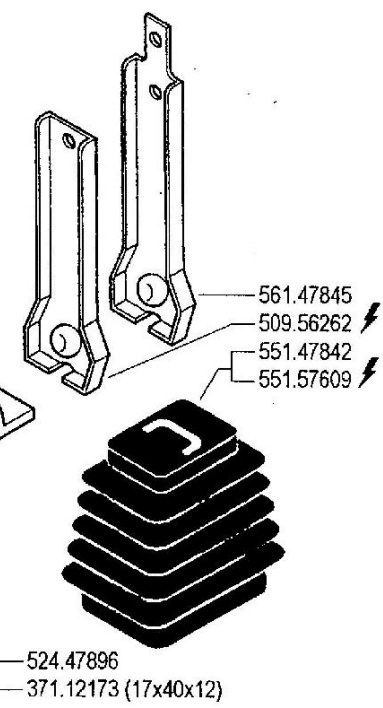
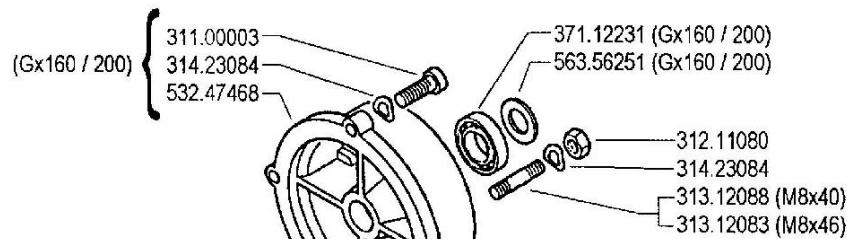

MOTORE ENGINE MOTEUR MOTOR	A	FRIZIONE EMBRAGUE EMBRAYAGE KUPPLUNG CLUTCH
Acme A 220		592.47884
A349★ - A360★ - ACT 280		592.47884
ACT 340		592.47971
Honda Gx 160 / 200		592.56265★ (1)
Intermotor IM 359		592.47884
Lombardini 6 LD 435		592.47971
Lombardini 15 LD 315 / 350		592.47884
Yanmar L100 AE		592.47971

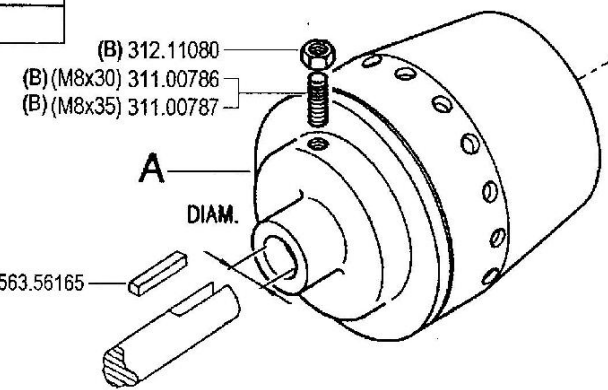
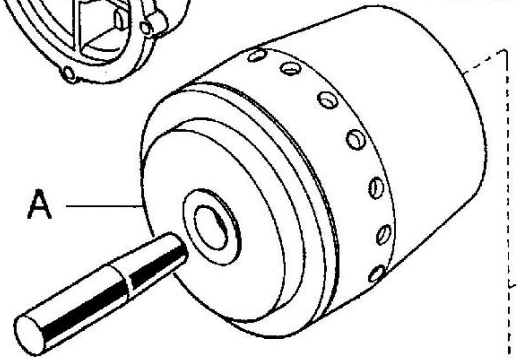

NON SMONTARE MAI LA FRIZIONE
NEVER DISASSEMBLE THE CLUTCH
NE DEMONTER JAMAIS L'EMBRAYAGE
NIEMALS DIE KUPPLUNG AUSBAUEN
NO DESMONTAR JAMAS EL FMBRAGUE

(*) serrate a 2 kgm

(1) sostituisce 592.56252

FERRARI	300 serie 95	FRIZIONE A CONO AUTOVENTILANTE		DALLA MACCHINA DE LA MAQUINA DE LA MACHINE FROM THE MACHINE AB DER MASCHINE	AGGIORNAMENTO	03	Rev. 2
		CLUTCH EMBRAGUE	EMBRAYAGE KUPPLUNG		REVISION		
				★N	MISE A JOUR		
					APLAZAMIENTO		
					ANPASSUNG	10/2001	

REV.01

Pos.	Code	Q.ty	Description	Notes
31100003	31100003	0	SCREW TE 5/16X7/8	
31100786	31100786	0	SCREW STEI M8X30 UNI5923 8G	
31100787	31100787	0	SCREW STEI M8X35 UNI5923 8G	
31211080	31211080	0	NUT M8	
31312083	31312083	0	STUD BOLT M8X46X16X16	
31312088	31312088	0	STUD BOLT M8X40X14X14	
31423084	31423084	0	SPRING WASHER 8,4	
37112173	37112173	0	BEARING	
37112231	37112231	0	BEARING	
50956262	50956262	0	CLUTCH LEVER	
52447896	52447896	0	PRESSURE PLATE	
53247468	53247468	0	FLANGE	
55147842	55147842	0	BELLOWS	
55157609	55157609	0	BELLOWS	
56147845	56147845	0	CLUTCH LEVER	
56356165	56356165	0	DOWEL	
56356251	56356251	0	SHIM D=19,6	
59247884	59247884	0	CLUTCH ASSY	
59247971	59247971	0	CLUTCH	
59256265	59256265	0	CLUTCH ASSY	

- ★(Gx240/270) 31100015
(Gx160/200) 31100003
- ★(Gx240/270) 53156150
(Gx160/200) 53247468
- ★(Gx240/270) 31423105
(Gx160/200) 31423084
- ★(Gx240/270) 37112233
(Gx160/200) 37112231
- 56347484 (Gx240/270) ★
- 56356251 (Gx160/200)
- 31211080
- 31241080 ⚡
- 31423084
- 31312088 (M8x40)
- 31312083 (M8x46)

MOTORE ENGINE MOTEUR MOTOR	A	FRIZIONE CLUTCH EMBRAYAGE EMBRAGUE KUPPLUNG
AcmeA220		59247884
A349 - A360 - ACT280		59247884
ACT340		59247971
Honda Gx160/200		59256271 ★(1)
Honda Gx240/270 ★		59256253
Lombardini 15LD315/350		59247884
Lombardini 15LD500 ★		59247924
Yanmar L70AE ★		59247884
Yanmar L100AE		59247971

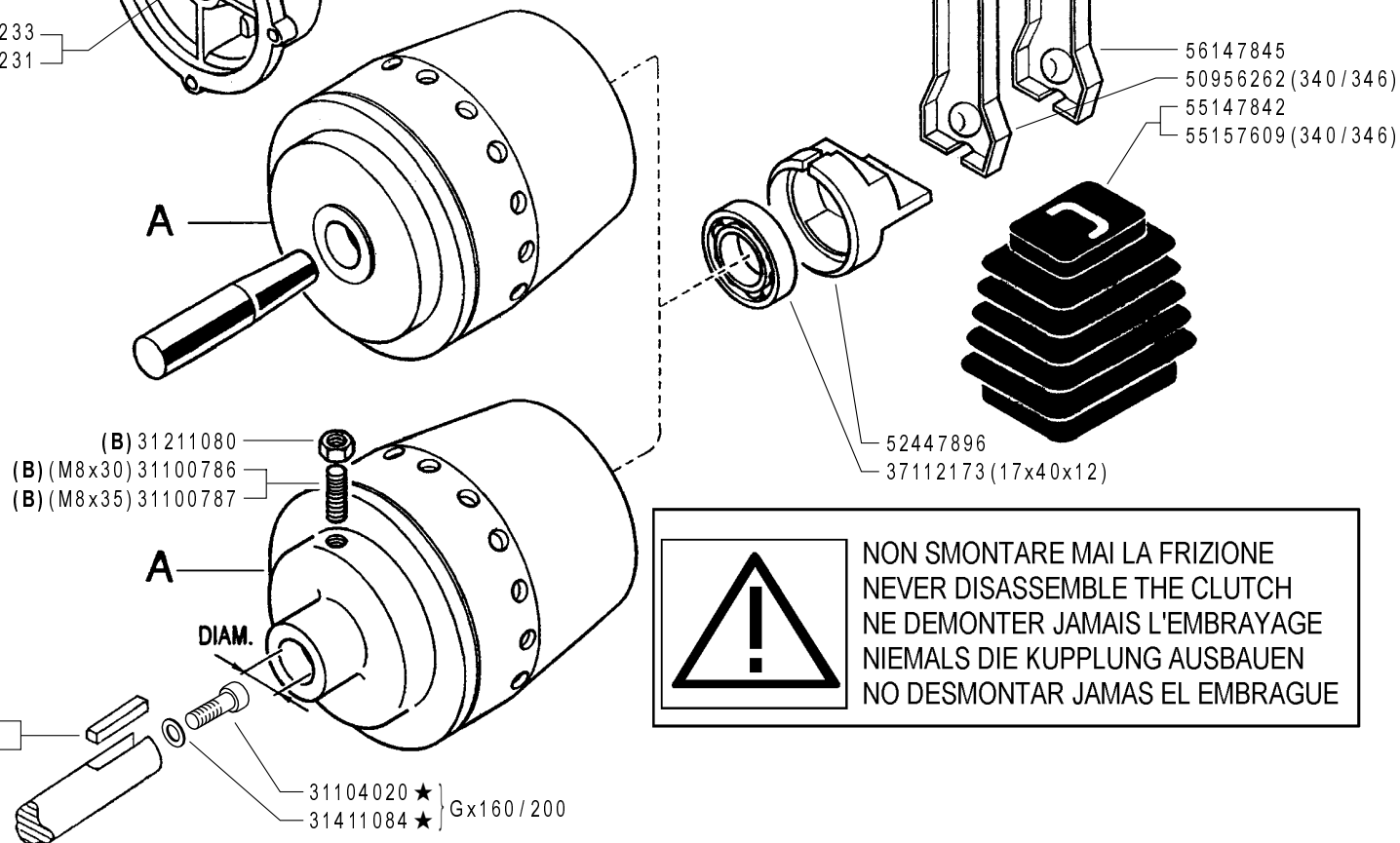

(1) sostituisce 59256265

FERRARI	300 serie 95	FRIZIONE A CONO AUTOVENTILANTE	DALLA MACCHINA		Rev.	
			DE LA MAQUINA			
			DE LA MACHINE	(1) 763195		03
			FROM THE MACHINE	752002 (346)		3
		CLUTCH	EMBRAYAGE			
		EMBRAGUE	KUPPLUNG			
			★N.	749391 (340)	02/2006	

(B) serrare a 2 kgm

ZENNE

Pos.	Code	Q.ty	Description	Notes
31100003	31100003	1	SCREW TE 5/16X7/8	
31100015	31100015	1	SCREW TE 3/8X1	
31100786	31100786	1	SCREW STEI M8X30 UNI5923 8G	
31100787	31100787	1	SCREW STEI M8X35 UNI5923 8G	
31104020	31104020	1	SCREW TCCE 5/16X3/4 24 UNF 12K	
31211080	31211080	1	NUT M8	
31241080	31241080	1	HEXAGON SELFLOCK NUT M8	
31312083	31312083	1	STUD BOLT M8X46X16X16	
31312088	31312088	1	STUD BOLT M8X40X14X14	
31411084	31411084	1	WASHER 8,4x17	
31423084	31423084	1	SPRING WASHER 8,4	
31423105	31423105	1	SPRING WASHER 10,5	
37112173	37112173	1	BEARING	
37112231	37112231	1	BEARING	
37112233	37112233	1	BEARING	
50956262	50956262	1	CLUTCH LEVER	
52447896	52447896	1	PRESSURE PLATE	
53156150	53156150	1	ENGINE FLANGE	
53247468	53247468	1	FLANGE	
55147842	55147842	1	BELLOWS	
55157609	55157609	1	BELLOWS	
56147845	56147845	1	CLUTCH LEVER	
56347484	56347484	1	SHIM	
56349782	56349782	1	DOWEL	
56356165	56356165	1	DOWEL	
56356251	56356251	1	SHIM D=19,6	
59247884	59247884	1	CLUTCH ASSY	
59247924	59247924	1	CLUTCH	
59247971	59247971	1	CLUTCH	
59256253	59256253	1	CLUTCH ASSY	

SERIAL

003_03 - CLUTCH
Version: MC 346, MC 340

CODE REV
003_3_25078

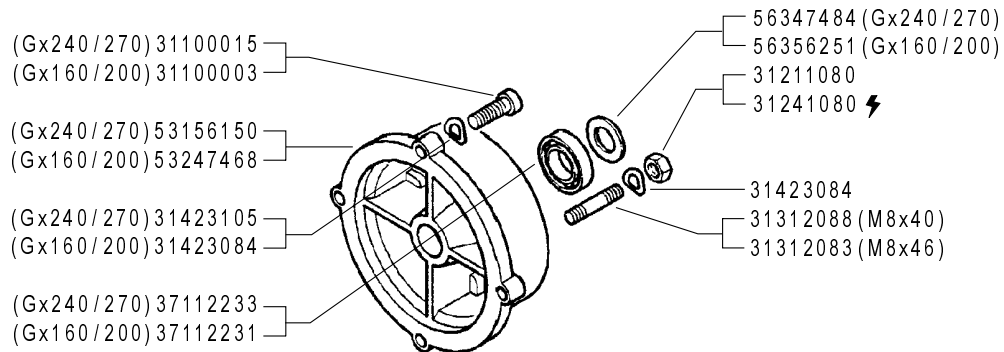

MOTORE ENGINE MOTEUR MOTOR	A	FRIZIONE CLUTCH EMBRAYAGE EMBRAGUE KUPPLUNG
AcmeA220		59247884
A349 - A360 - ACT280		59247884
ACT340		59247971
Honda Gx160/200 (D=19)		59256275 ★ (1)
Honda Gx240/270 (D=25,4)		59256279 ★ (2)
Lombardini 15LD315/350		59247884
Lombardini 15LD500		59247924
Yanmar L70AE		59247884
Yanmar L100AE		59247971

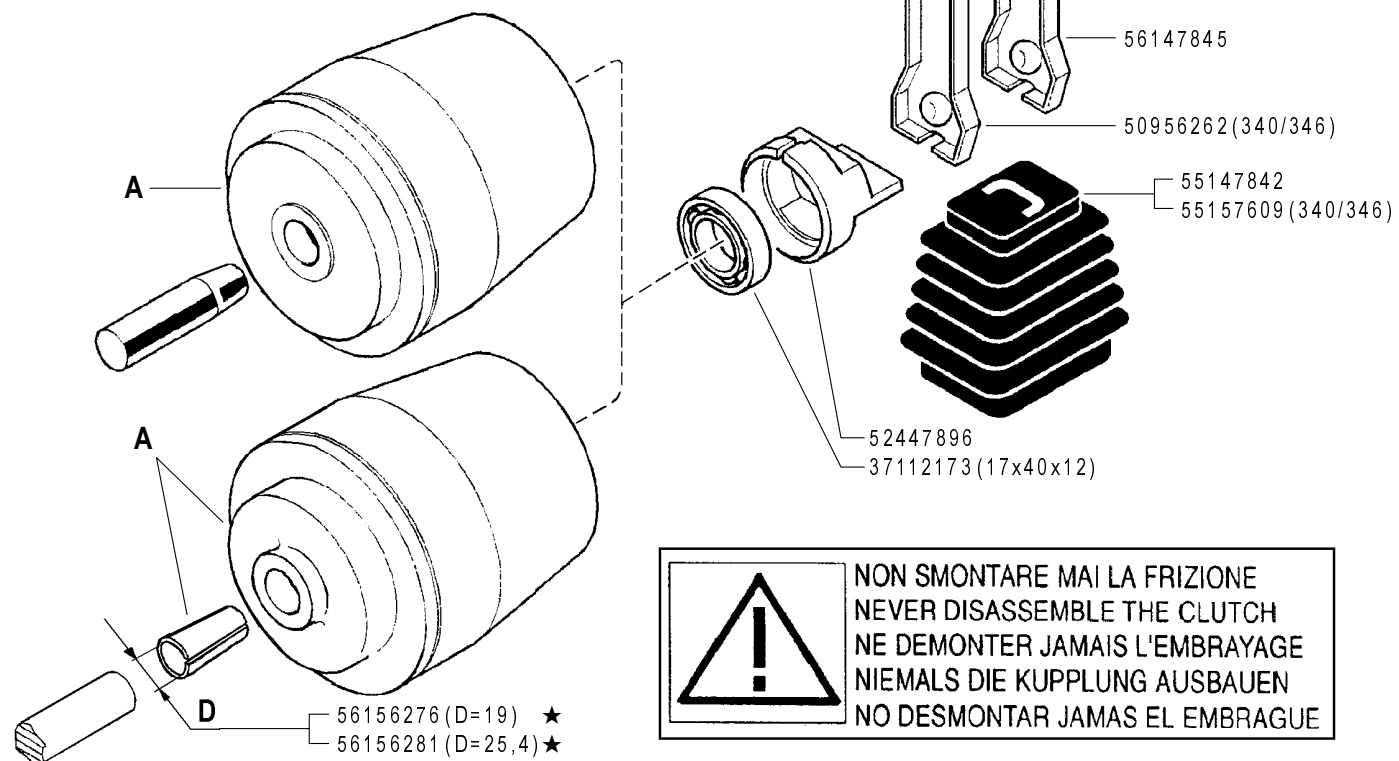

**NON SMONTARE MAI LA FRIZIONE
 NEVER DISASSEMBLE THE CLUTCH
 NE DEMONTER JAMAIS L'EMBRAYAGE
 NIEMALS DIE KUPPLUNG AUSBAUEN
 NO DESMONTAR JAMAS EL EMBRAGUE**

(2) sostituisce 59256253
 (1) sostituisce 59256271

FERRARI

300 serie 95

FRIZIONE A CONO AUTOVENTILANTE

CLUTCH
EMBRAGUE

EMBRAYAGE
KUPPLUNG

DALLA MACCHINA
DE LA MAQUINA
DE LA MACHINE
FROM THE MACHINE
AB DER MASCHINE

CHIEDERE A S.A.T.

ASK TO S.A.T.

DEMANDER A S.A.T.

SOLICITAR EL S.A.T.

ANFRAGEN DER S.A.T.

03

Rev.
4

11/2006

★N.

ZENNE

Pos.	Code	Q.ty	Description	Notes
31100003	31100003	1	SCREW TE 5/16X7/8	
31100015	31100015	1	SCREW TE 3/8X1	
31211080	31211080	1	NUT M8	
31241080	31241080	1	HEXAGON SELFLOCK NUT M8	
31312083	31312083	1	STUD BOLT M8X46X16X16	
31312088	31312088	1	STUD BOLT M8X40X14X14	
31423084	31423084	1	SPRING WASHER 8,4	
31423105	31423105	1	SPRING WASHER 10,5	
37112173	37112173	1	BEARING	
37112231	37112231	1	BEARING	
37112233	37112233	1	BEARING	
50956262	50956262	1	CLUTCH LEVER	
52447896	52447896	1	PRESSURE PLATE	
53156150	53156150	1	ENGINE FLANGE	
53247468	53247468	1	FLANGE	
55147842	55147842	1	BELLOWS	
55157609	55157609	1	BELLOWS	
56147845	56147845	1	CLUTCH LEVER	
56156276	56156276	1	SLEEVE	
56156281	56156281	1	CENTRING BUSH	
56347484	56347484	1	SHIM	
56356251	56356251	1	SHIM D=19,6	
59247884	59247884	1	CLUTCH ASSY	
59247924	59247924	1	CLUTCH	
59247971	59247971	1	CLUTCH	
59256275	59256275	1	CLUTCH ASSY	
59256279	59256279	1	CLUTCH ASSY	

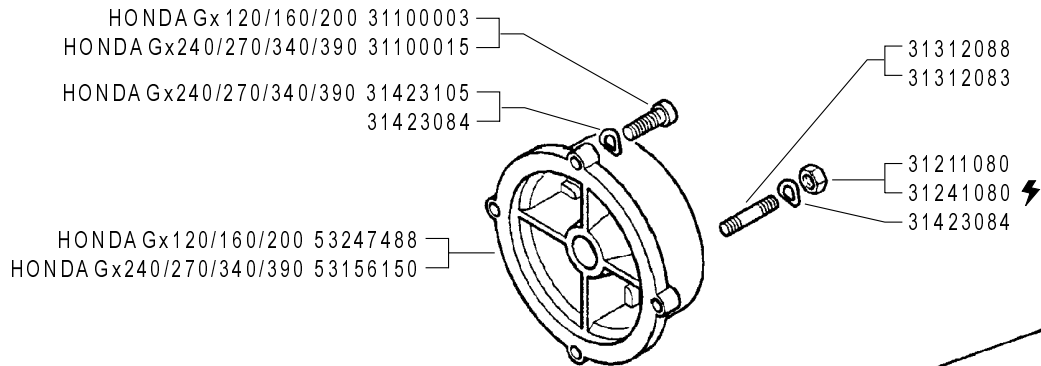

MOTORE ENGINE MOTEUR MOTOR MOTOR	FRIZIONE CLUTCH A EMBRAYAGE EMBRAGUE KUPPLUNG
Acme A220	59247884
Acme A220 (REF.)	59256255
Acme ACT280 - A349 - A360	59247884
Acme ACT340	59247971
Honda Gx390 - Gx340 D=25,4	59256280
Honda Gx240/270 D=25,4	59256279
Honda Gx120/160/200 D=19	59256275
Lombardini 15LD315/350	59247884
Lombardini 15LD500	59247924
Yanmar L100AE	59247971
Yanmar L70AE	59247884

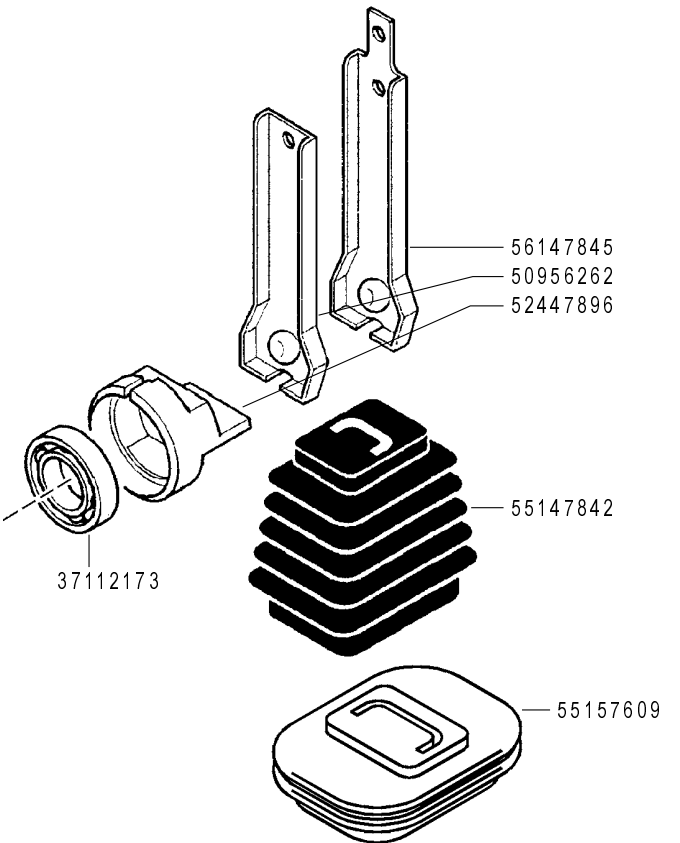
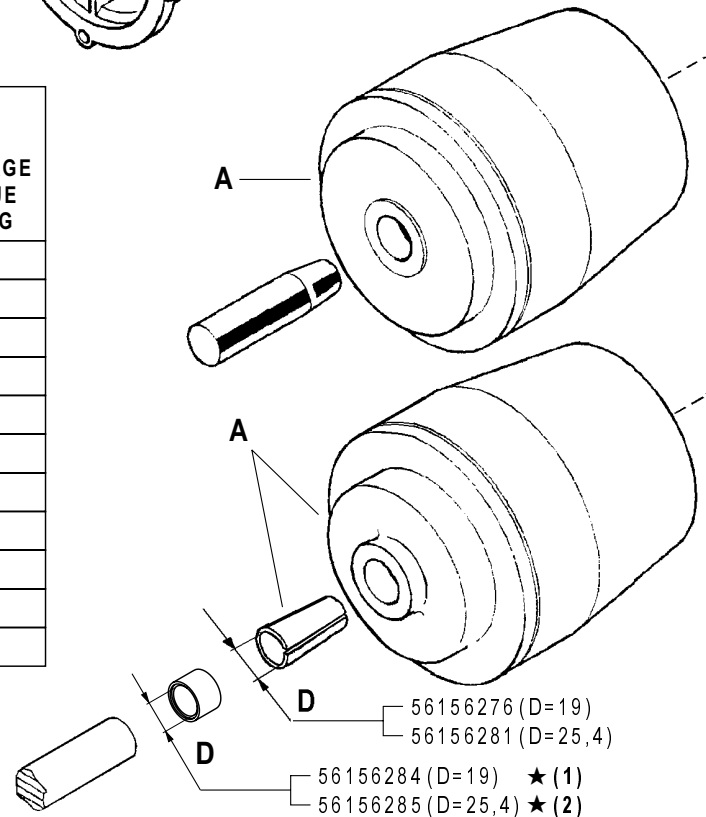

! NON SMONTARE MAI LA FRIZIONE
NEVER DISASSEMBLE THE CLUTCH
NE DEMONTER JAMAIS L'EMBRAYAGE
NIEMALS DIE KUPPLUNG AUSBAUEN
NO DESMONTAR JAMAS EL EMBRAGUE

FERRARI

300 serie **95**

FRIZIONE A CONO AUTOVENTILANTE

CLUTCH
EMBRAGUE

EMBRAYAGE
KUPPLUNG

DALLA MACCHINA
DE LA MAQUINA
FROM THE MACHINE
AB DER MASCHINE

★N.

(2) 799519

(1) 779324

03

Rev.
5

11/2006

ZENNE

Pos.	Code	Q.ty	Description	Notes
31100003	31100003	1	SCREW TE 5/16X7/8	
31100015	31100015	1	SCREW TE 3/8X1	
31211080	31211080	1	NUT M8	
31241080	31241080	1	HEXAGON SELFLOCK NUT M8	
31312083	31312083	1	STUD BOLT M8X46X16X16	
31312088	31312088	1	STUD BOLT M8X40X14X14	
31423084	31423084	1	SPRING WASHER 8,4	
31423105	31423105	1	SPRING WASHER 10,5	
37112173	37112173	1	BEARING	
50956262	50956262	1	CLUTCH LEVER	
52447896	52447896	1	PRESSURE PLATE	
53156150	53156150	1	ENGINE FLANGE	
53247488	53247488	1	ENGINE FLANGE	
55147842	55147842	1	BELLOWS	
55157609	55157609	1	BELLOWS	
56147845	56147845	1	CLUTCH LEVER	
56156276	56156276	1	SLEEVE	
56156281	56156281	1	CENTRING BUSH	
56156284	56156284	1	SPACER	
56156285	56156285	1	SPACER	
59247884	59247884	1	CLUTCH ASSY	
59247924	59247924	1	CLUTCH	
59247971	59247971	1	CLUTCH	
59256255	59256255	1	CLUTCH ASSY	
59256275	59256275	1	CLUTCH ASSY	
59256279	59256279	1	CLUTCH ASSY	
59256280	59256280	1	CLUTCH ASSY	

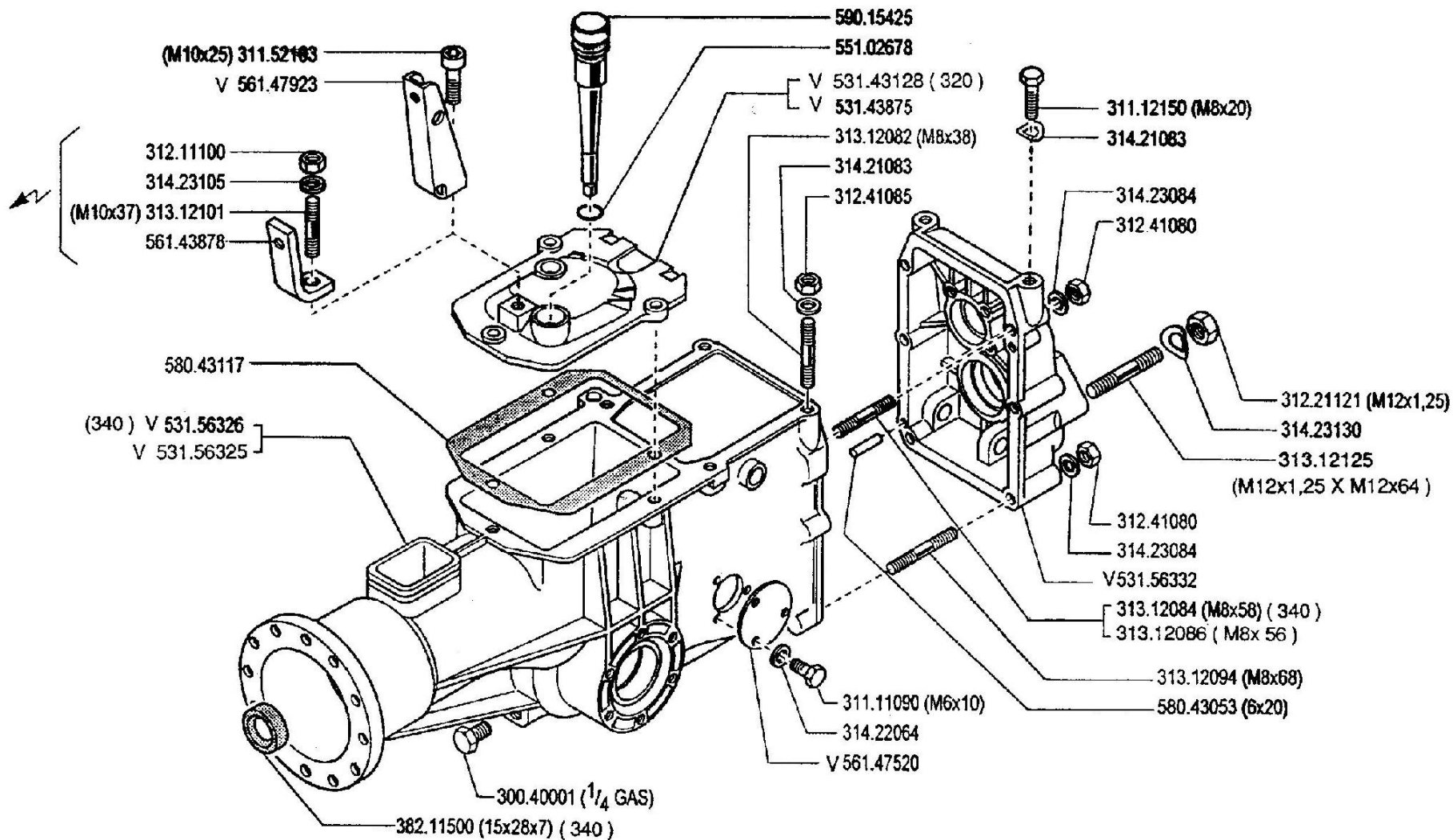

V = verde - vert - green - grün

FERRARI

300 serie **95**

SCATOLA CAMBIO

CAJA DE CAMBIO

BOITE DE VITESSES

GEARBOX

WECHSELGETRIEBE

DALLA MACCHINA
DE LA MAQUINA
DE LA MACHINE
FROM THE MACHINE
AB DER MASCHINE

N.

04.00

01.06.1995

Pos.	Code	Q.ty	Description	Notes
30040001	30040001	0	PLUG	
31111090	31111090	0	SCREW TE M5X10 UNI 5739 8G	
31112150	31112150	0	SCREW TE M8X20 UNI 5739 8G	
31152103	31152103	0	SCREW TCEI M10X25 UNI 5931	
31211100	31211100	0	NUT M10	
31221121	31221121	0	NUT M12X1,25	
31241080	31241080	0	HEXAGON SELFLOCK NUT M8	
31241085	31241085	0	SELFLOCK NUT M8 6S	
31312082	31312082	0	STUD BOLT M8X38X14X20	
31312084	31312084	0	STUD BOLT M8X58X16X16	
31312086	31312086	0	STUD BOLT M8X56X20X14	
31312094	31312094	0	STUD BOLT M8X68X14X36	
31312101	31312101	0	STUD BOLT M10X37X15X19	
31312125	31312125	0	STUD BOLT	
31421083	31421083	0	WASHER	
31422064	31422064	0	SPRING WASHER 6,4	
31423084	31423084	0	SPRING WASHER 8,4	
31423105	31423105	0	SPRING WASHER 10,5	
31423130	31423130	0	SPRING WASHER 13	
38211500	38211500	0	OIL SEAL 15X28X7	
53143128	53143128	0	COVER	
53143875	53143875	0	GEARBOX HOUSING COVER	
53156325	53156325	0	BODY	
53156326	53156326	0	BODY	
53156332	53156332	0	REAR COVER	
55102678	55102678	0	RUBBER RING	
56143878	56143878	0	BRACKET	
56147520	56147520	0	COVER	
56147923	56147923	0	BRACKET	
58043053	58043053	0	CYLINDRICAL PLUG	
58043117	58043117	0	COVER GASKET	
59015425	59015425	0	PLUG	

SERIAL

004_00 - GEARBOX

CODE REV

004_0_10617

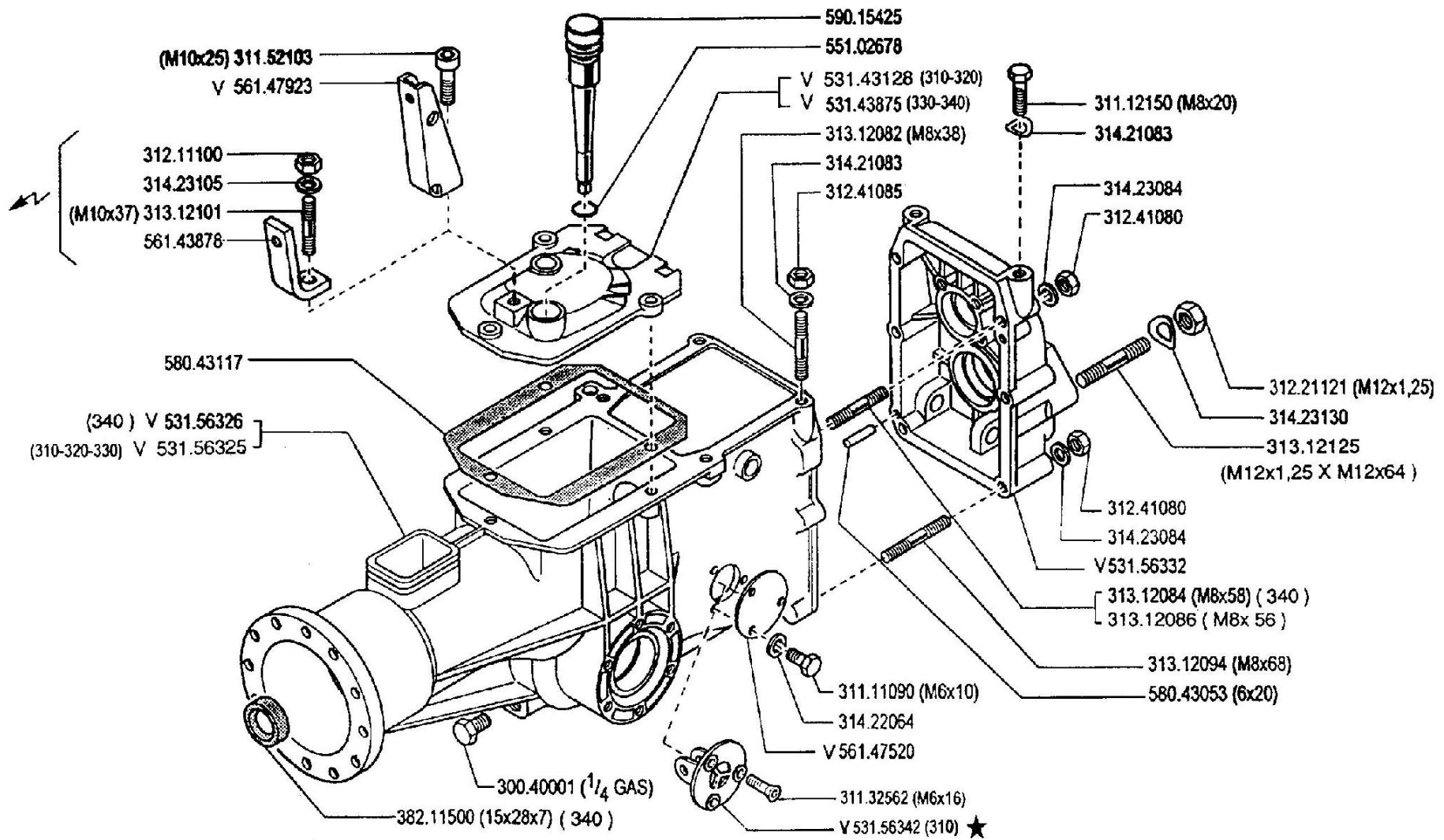

V = verde - vert - green - grün

FERRARI

300 serie **95**

SCATOLA CAMBIO

CAJA DE CAMBIO
BOITE DE VITESSES

GEARBOX

WECHSELGETRIEBE

DALLA MACCHINA
DE LA MAQUINA
DE LA MACHINE
FROM THE MACHINE
AB DER MASCHINE

AGGIORNAMENTO	04.01
REVISION	
MISE A JOUR	9/1997
APLAZAMIENTO	
ANPASSUNG	

★ N.

Pos.	Code	Q.ty	Description	Notes
30040001	30040001	0	PLUG	
31111090	31111090	0	SCREW TE M5X10 UNI 5739 8G	
31112150	31112150	0	SCREW TE M8X20 UNI 5739 8G	
31132562	31132562	0	SCREW TSVEI M6X16 UNI 5933	
31152103	31152103	0	SCREW TCEI M10X25 UNI 5931	
31211100	31211100	0	NUT M10	
31221121	31221121	0	NUT M12X1,25	
31241080	31241080	0	HEXAGON SELFLOCK NUT M8	
31241085	31241085	0	SELFLOCK NUT M8 6S	
31312082	31312082	0	STUD BOLT M8X38X14X20	
31312084	31312084	0	STUD BOLT M8X58X16X16	
31312086	31312086	0	STUD BOLT M8X56X20X14	
31312094	31312094	0	STUD BOLT M8X68X14X36	
31312101	31312101	0	STUD BOLT M10X37X15X19	
31312125	31312125	0	STUD BOLT	
31421083	31421083	0	WASHER	
31422064	31422064	0	SPRING WASHER 6,4	
31423084	31423084	0	SPRING WASHER 8,4	
31423105	31423105	0	SPRING WASHER 10,5	
31423130	31423130	0	SPRING WASHER 13	
38211500	38211500	0	OIL SEAL 15X28X7	
53143128	53143128	0	COVER	
53143875	53143875	0	GEARBOX HOUSING COVER	
53156325	53156325	0	BODY	
53156326	53156326	0	BODY	
53156332	53156332	0	REAR COVER	
53156342	53156342	0	GEAR SUPPORT	
55102678	55102678	0	RUBBER RING	
56143878	56143878	0	BRACKET	
56147520	56147520	0	COVER	
56147923	56147923	0	BRACKET	
58043053	58043053	0	CYLINDRICAL PLUG	
58043117	58043117	0	COVER GASKET	
59015425	59015425	0	PLUG	

SERIAL

004_01 - GEARBOX

CODE REV

004_1_10650

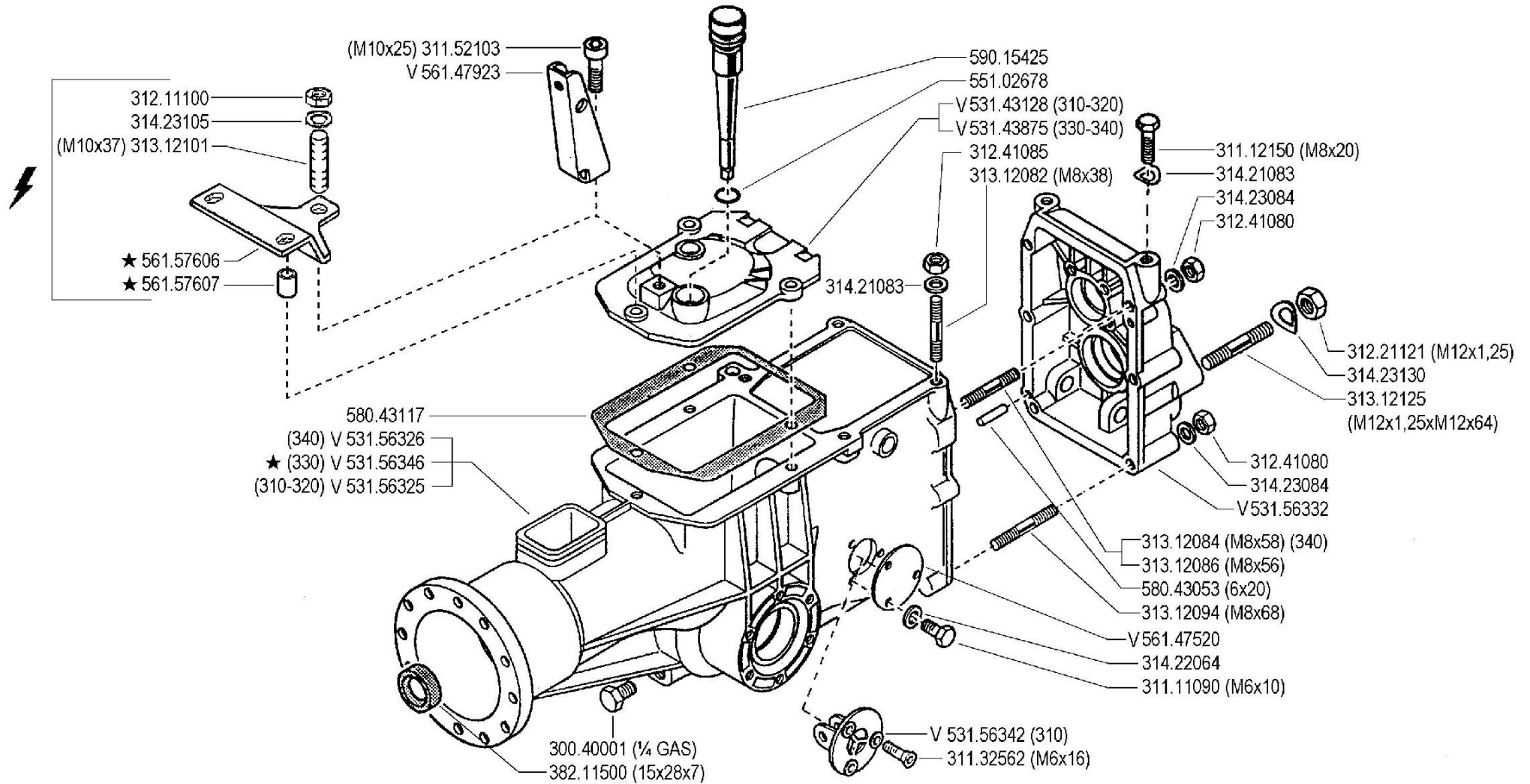

V = verde - green - vert - grün

FERRARI

300 serie **95**

SCATOLA CAMBIO

GEARBOX
CAJA DE CAMBIO

BOITE DE VITESSES
WECHSELGETRIEBE

DALLA MACCHINA
DE LA MAQUINA
DE LA MACHINE
FROM THE MACHINE
AB DER MASCHINE

AGGIORNAMENTO

REVISION

MISE A JOUR

APLAZAMIENTO

ANPASSUNG

04 **02**

1/2000

★N.

Pos.	Code	Q.ty	Description	Notes
30040001	30040001	0	PLUG	
31111090	31111090	0	SCREW TE M5X10 UNI 5739 8G	
31112150	31112150	0	SCREW TE M8X20 UNI 5739 8G	
31132562	31132562	0	SCREW TSVEI M6X16 UNI 5933	
31152103	31152103	0	SCREW TCEI M10X25 UNI 5931	
31211100	31211100	0	NUT M10	
31221121	31221121	0	NUT M12X1,25	
31241080	31241080	0	HEXAGON SELFLOCK NUT M8	
31241085	31241085	0	SELFLOCK NUT M8 6S	
31312082	31312082	0	STUD BOLT M8X38X14X20	
31312084	31312084	0	STUD BOLT M8X58X16X16	
31312086	31312086	0	STUD BOLT M8X56X20X14	
31312094	31312094	0	STUD BOLT M8X68X14X36	
31312101	31312101	0	STUD BOLT M10X37X15X19	
31312125	31312125	0	STUD BOLT	
31421083	31421083	0	WASHER	
31422064	31422064	0	SPRING WASHER 6,4	
31423084	31423084	0	SPRING WASHER 8,4	
31423105	31423105	0	SPRING WASHER 10,5	
31423130	31423130	0	SPRING WASHER 13	
38211500	38211500	0	OIL SEAL 15X28X7	
53143128	53143128	0	COVER	
53143875	53143875	0	GEARBOX HOUSING COVER	
53156325	53156325	0	BODY	
53156326	53156326	0	BODY	
53156332	53156332	0	REAR COVER	
53156342	53156342	0	GEAR SUPPORT	
53156346	53156346	0	BODY	
55102678	55102678	0	RUBBER RING	
56147520	56147520	0	COVER	
56147923	56147923	0	BRACKET	
56157606	56157606	0	STOP	
56157607	56157607	0	SPACER	
58043053	58043053	0	CYLINDRICAL PLUG	

SERIAL

004_02 - GEARBOX

CODE REV

004_2_10685

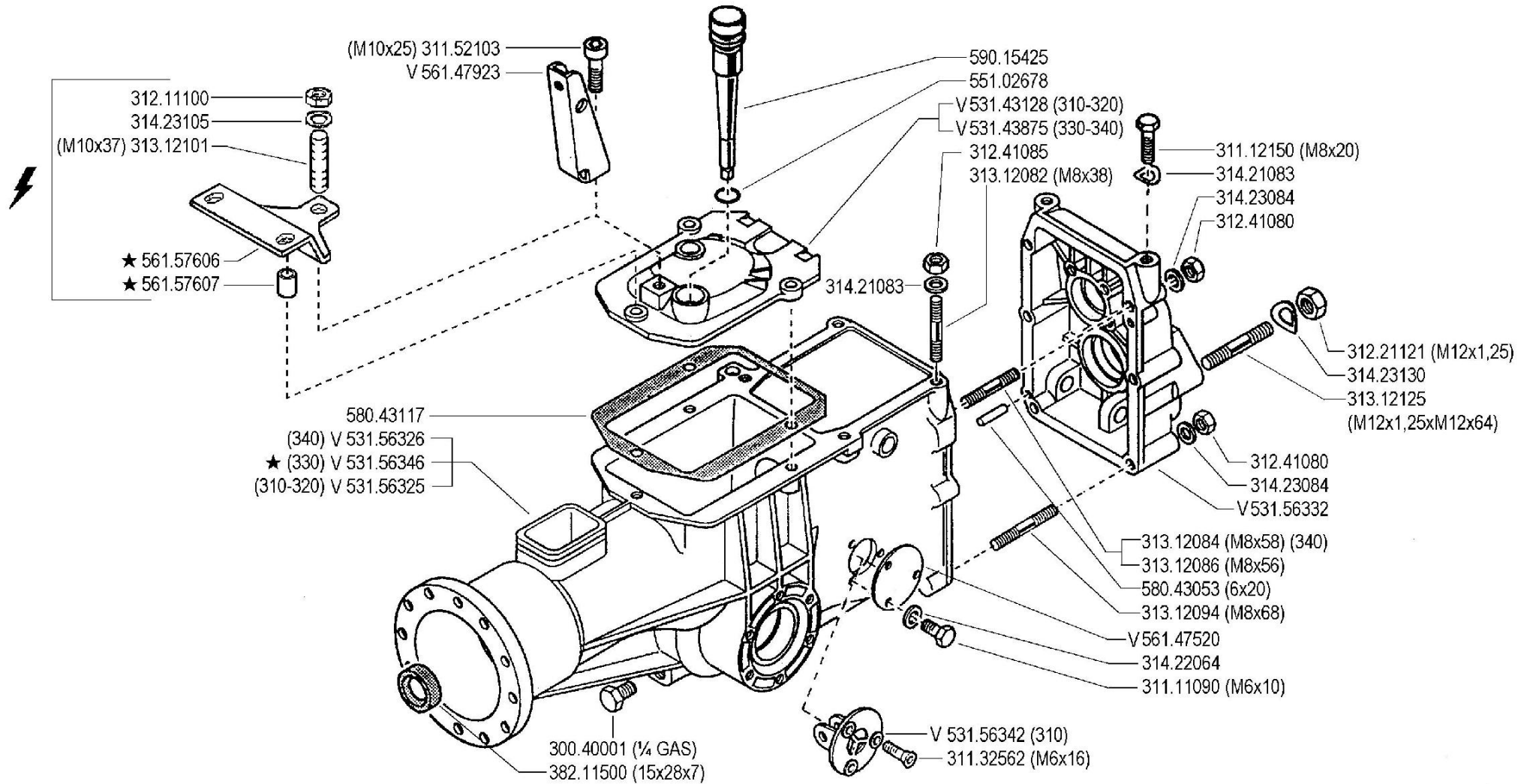

V = verde - green - vert - grün

FERRARI

300 serie **95**

SCATOLA CAMBIO

GEARBOX
CAJA DE CAMBIO

BOITE DE VITESSES
WECHSELGETRIEBE

DALLA MACCHINA
DE LA MAQUINA
DE LA MACHINE
FROM THE MACHINE
AB DER MASCHINE

AGGIORNAMENTO

REVISION

MISE A JOUR

APLAZAMIENTO

ANPASSUNG

04 **02**

1/2000

★N.

Pos.	Code	Q.ty	Description	Notes
58043117	58043117	0	COVER GASKET	
59015425	59015425	0	PLUG	

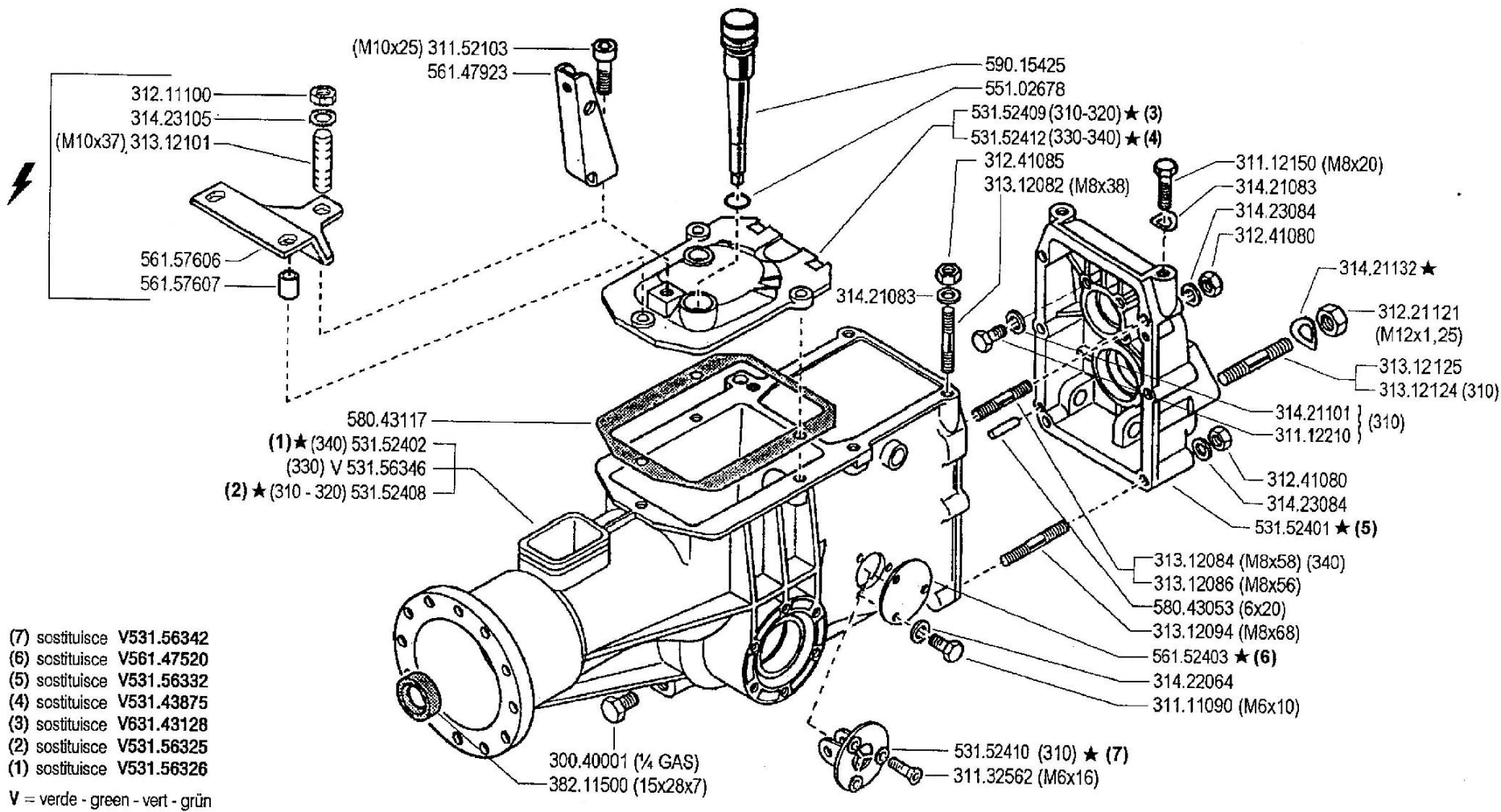

- (7) sostituisce V531.56342
 - (6) sostituisce V561.47520
 - (5) sostituisce V531.56332
 - (4) sostituisce V531.43875
 - (3) sostituisce V631.43128
 - (2) sostituisce V531.56325
 - (1) sostituisce V531.56326
- V = verde - green - vert - grün

FERRARI	300 serie 95	SCATOLA CAMBIO		DALLA MACCHINA DE LA MAQUINA DE LA MACHINE FROM THE MACHINE AB DER MASCHINE	AGGIORNAMENTO	04	Rev. 3
		GEARBOX			REVISION		
		CAJA DE CAMBIO			MISE A JOUR		
		BOITE DE VITESSES			APLAZAMIENTO		
		WECHSELGETRIEBE			ANPASSUNG		
★N				12/2002			

ZENNE

Pos.	Code	Q.ty	Description	Notes
30040001	30040001	0	PLUG	
31111090	31111090	0	SCREW TE M5X10 UNI 5739 8G	
31112150	31112150	0	SCREW TE M8X20 UNI 5739 8G	
31112210	31112210	0	SCREW TE M10X20 UNI 5739	
31132562	31132562	0	SCREW TSVEI M6X16 UNI 5933	
31152103	31152103	0	SCREW TCEI M10X25 UNI 5931	
31211100	31211100	0	NUT M10	
31221121	31221121	0	NUT M12X1,25	
31241080	31241080	0	HEXAGON SELFLOCK NUT M8	
31241085	31241085	0	SELFLOCK NUT M8 6S	
31312082	31312082	0	STUD BOLT M8X38X14X20	
31312084	31312084	0	STUD BOLT M8X58X16X16	
31312086	31312086	0	STUD BOLT M8X56X20X14	
31312094	31312094	0	STUD BOLT M8X68X14X36	
31312101	31312101	0	STUD BOLT M10X37X15X19	
31312124	31312124	0	STUD BOLT	
31312125	31312125	0	STUD BOLT	
31421083	31421083	0	WASHER	
31421101	31421101	0	WASHER	
31421132	31421132	0	WASHER 13X24X2,8	
31422064	31422064	0	SPRING WASHER 6,4	
31423084	31423084	0	SPRING WASHER 8,4	
31423105	31423105	0	SPRING WASHER 10,5	
38211500	38211500	0	OIL SEAL 15X28X7	
53143128	53143128	0	COVER	
53143875	53143875	0	GEARBOX HOUSING COVER	
53152401	53152401	0	REAR COVER	
53152402	53152402	0	BODY	
53152408	53152408	0	BODY	
53152409	53152409	0	COVER	
53152410	53152410	0	GEAR SUPPORT	
53152412	53152412	0	COVER	
53156325	53156325	0	BODY	
53156326	53156326	0	BODY	

SERIAL

004_03 - GEARBOX

CODE REV

004_3_10722

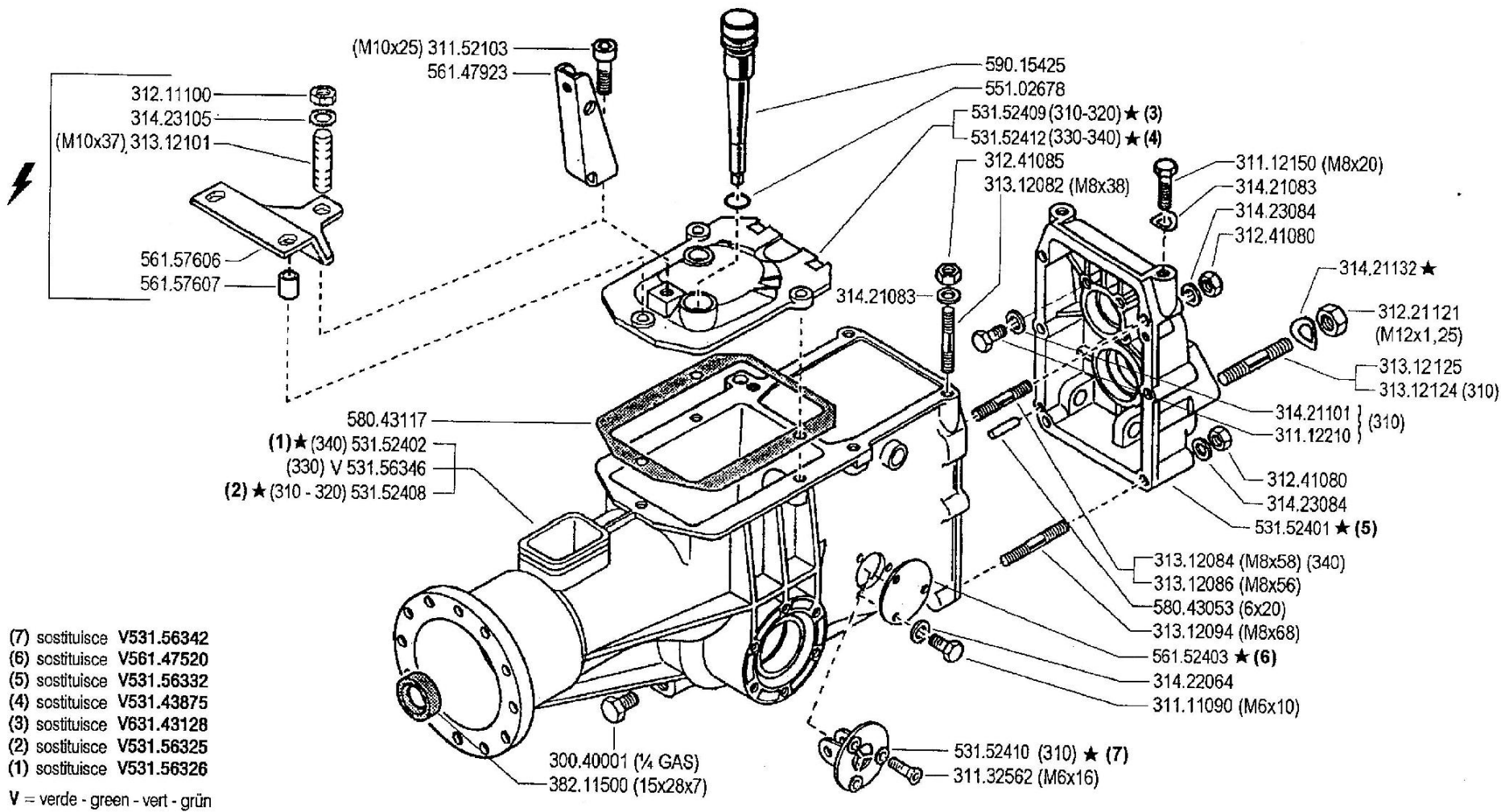

- (7) sostituisce V531.56342
 - (6) sostituisce V561.47520
 - (5) sostituisce V531.56332
 - (4) sostituisce V531.43875
 - (3) sostituisce V631.43128
 - (2) sostituisce V531.56325
 - (1) sostituisce V531.56326
- V = verde - green - vert - grün

FERRARI	300 serie 95	SCATOLA CAMBIO		DALLA MACCHINA DE LA MAQUINA DE LA MACHINE FROM THE MACHINE AB DER MASCHINE	AGGIORNAMENTO	04	Rev. 3
		GEARBOX			REVISION		
		CAJA DE CAMBIO			MISE A JOUR		
		BOITE DE VITESSES			APLAZAMIENTO		
		WECHSELGETRIEBE			ANPASSUNG		
★N				12/2002			

ZENNE

Pos.	Code	Q.ty	Description	Notes
53156332	53156332	0	REAR COVER	
53156342	53156342	0	GEAR SUPPORT	
53156346	53156346	0	BODY	
55102678	55102678	0	RUBBER RING	
56147520	56147520	0	COVER	
56147923	56147923	0	BRACKET	
56152403	56152403	0	COVER	
56157606	56157606	0	STOP	
56157607	56157607	0	SPACER	
58043053	58043053	0	CYLINDRICAL PLUG	
58043117	58043117	0	COVER GASKET	
59015425	59015425	0	PLUG	

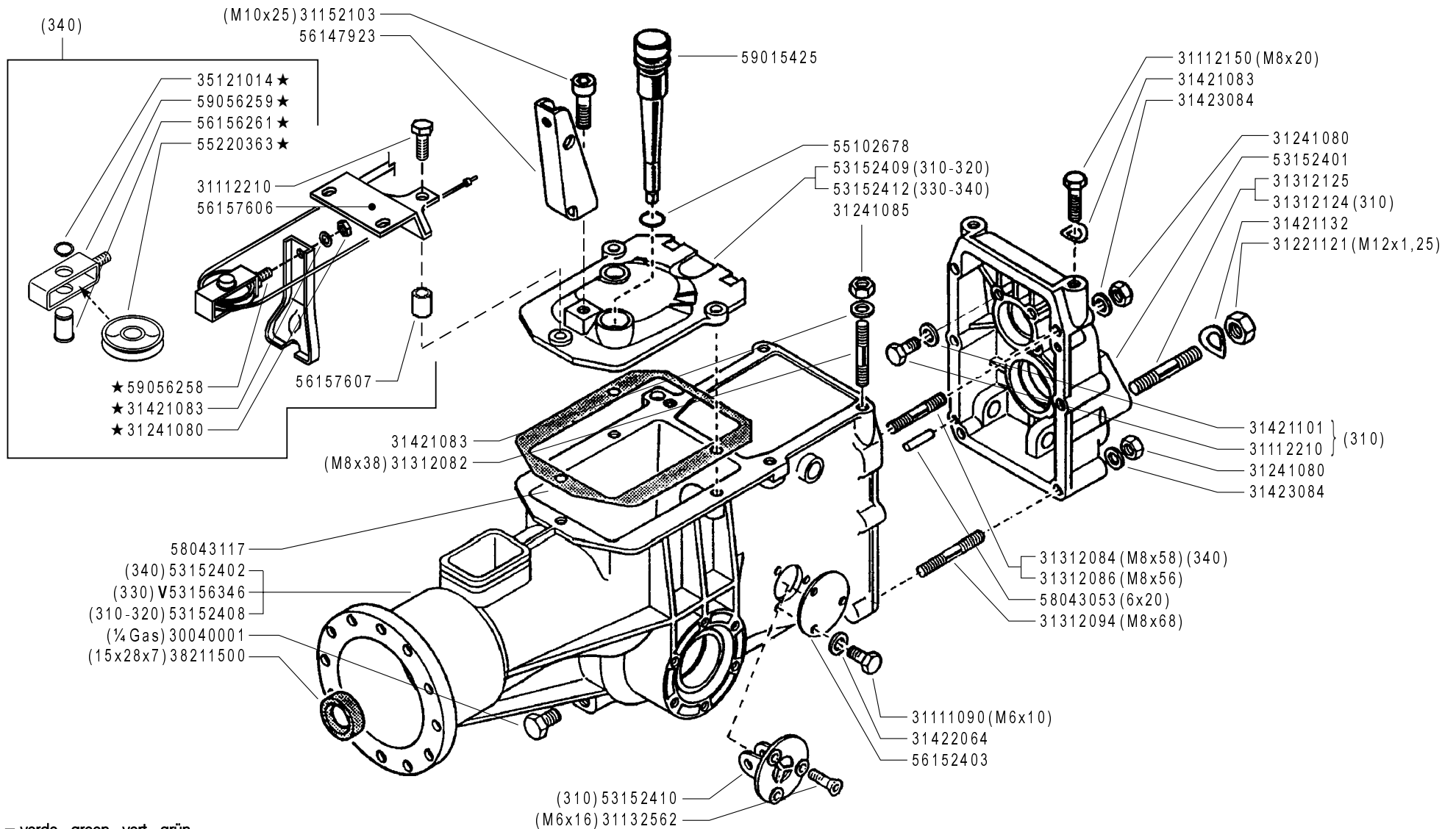

FERRARI

300 serie **95**

GEARBOX
CAJA DE CAMBIO

SCATOLA CAMBIO

BOITE DE VITESSES
WECHSELGETRIEBE

DALLA MACCHINA
DE LA MAQUINA
DE LA MACHINE
FROM THE MACHINE
AB DER MASCHINE

★ **N.**

749391 (340)

04 4

02/2006

ZENNE

Pos.	Code	Q.ty	Description	Notes
30040001	30040001	1	PLUG	
31111090	31111090	1	SCREW TE M5X10 UNI 5739 8G	
31112150	31112150	1	SCREW TE M8X20 UNI 5739 8G	
31112210	31112210	1	SCREW TE M10X20 UNI 5739	
31132562	31132562	1	SCREW TSVEI M6X16 UNI 5933	
31152103	31152103	1	SCREW TCEI M10X25 UNI 5931	
31221121	31221121	1	NUT M12X1,25	
31241080	31241080	1	HEXAGON SELFLOCK NUT M8	
31241085	31241085	1	SELFLOCK NUT M8 6S	
31312082	31312082	1	STUD BOLT M8X38X14X20	
31312084	31312084	1	STUD BOLT M8X58X16X16	
31312086	31312086	1	STUD BOLT M8X56X20X14	
31312094	31312094	1	STUD BOLT M8X68X14X36	
31312124	31312124	1	STUD BOLT	
31312125	31312125	1	STUD BOLT	
31421083	31421083	1	WASHER	
31421101	31421101	1	WASHER	
31421132	31421132	1	WASHER 13X24X2,8	
31422064	31422064	1	SPRING WASHER 6,4	
31423084	31423084	1	SPRING WASHER 8,4	
35121014	35121014	1	SEEGER RING	
38211500	38211500	1	OIL SEAL 15X28X7	
53152401	53152401	1	REAR COVER	
53152402	53152402	1	BODY	
53152408	53152408	1	BODY	
53152409	53152409	1	COVER	
53152410	53152410	1	GEAR SUPPORT	
53152412	53152412	1	COVER	
53156346	53156346	1	BODY	
55102678	55102678	1	RUBBER RING	
55220363	55220363	1	PULLEY	
56147923	56147923	1	BRACKET	
56152403	56152403	1	COVER	
56156261	56156261	1	PIN	

SERIAL
START
749391

004_04 - GEARBOX

Version: MC 340

CODE REV
004_4_25109

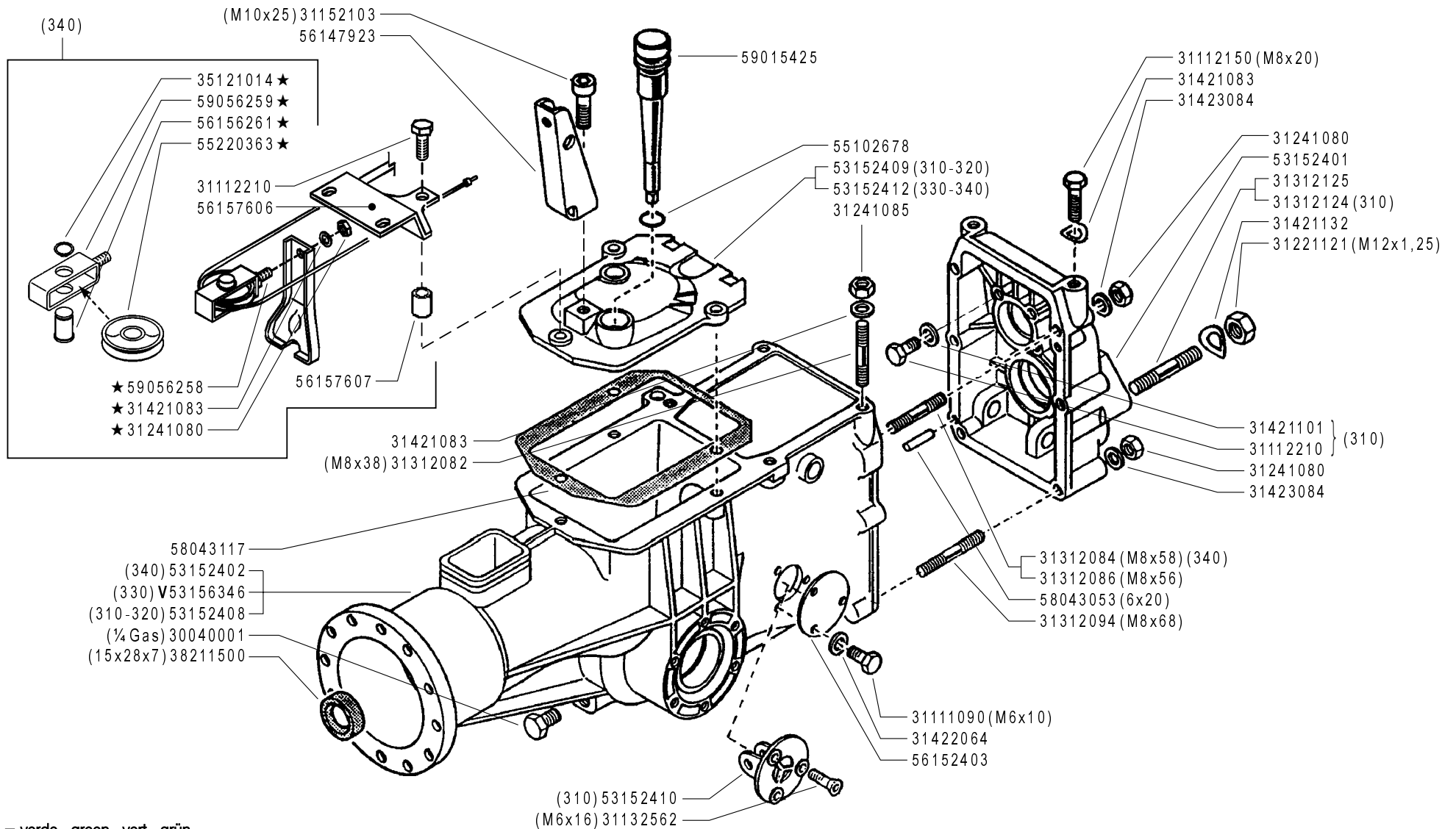

FERRARI

300 serie **95**

GEARBOX
CAJA DE CAMBIO

SCATOLA CAMBIO

BOITE DE VITESSES
WECHSELGETRIEBE

DALLA MACCHINA
DE LA MAQUINA
DE LA MACHINE
FROM THE MACHINE
AB DER MASCHINE

★ **N.**

749391 (340)

04 4

02/2006

ZENNE

Pos.	Code	Q.ty	Description	Notes
56157606	56157606	1	STOP	
56157607	56157607	1	SPACER	
58043053	58043053	1	CYLINDRICAL PLUG	
58043117	58043117	1	COVER GASKET	
59015425	59015425	1	PLUG	
59056258	59056258	1	CLUTCH FORK	
59056259	59056259	1	CLUTCH FORK	

SERIAL
START
749391

004_04 - GEARBOX

Version: MC 340

CODE REV
004_4_25109

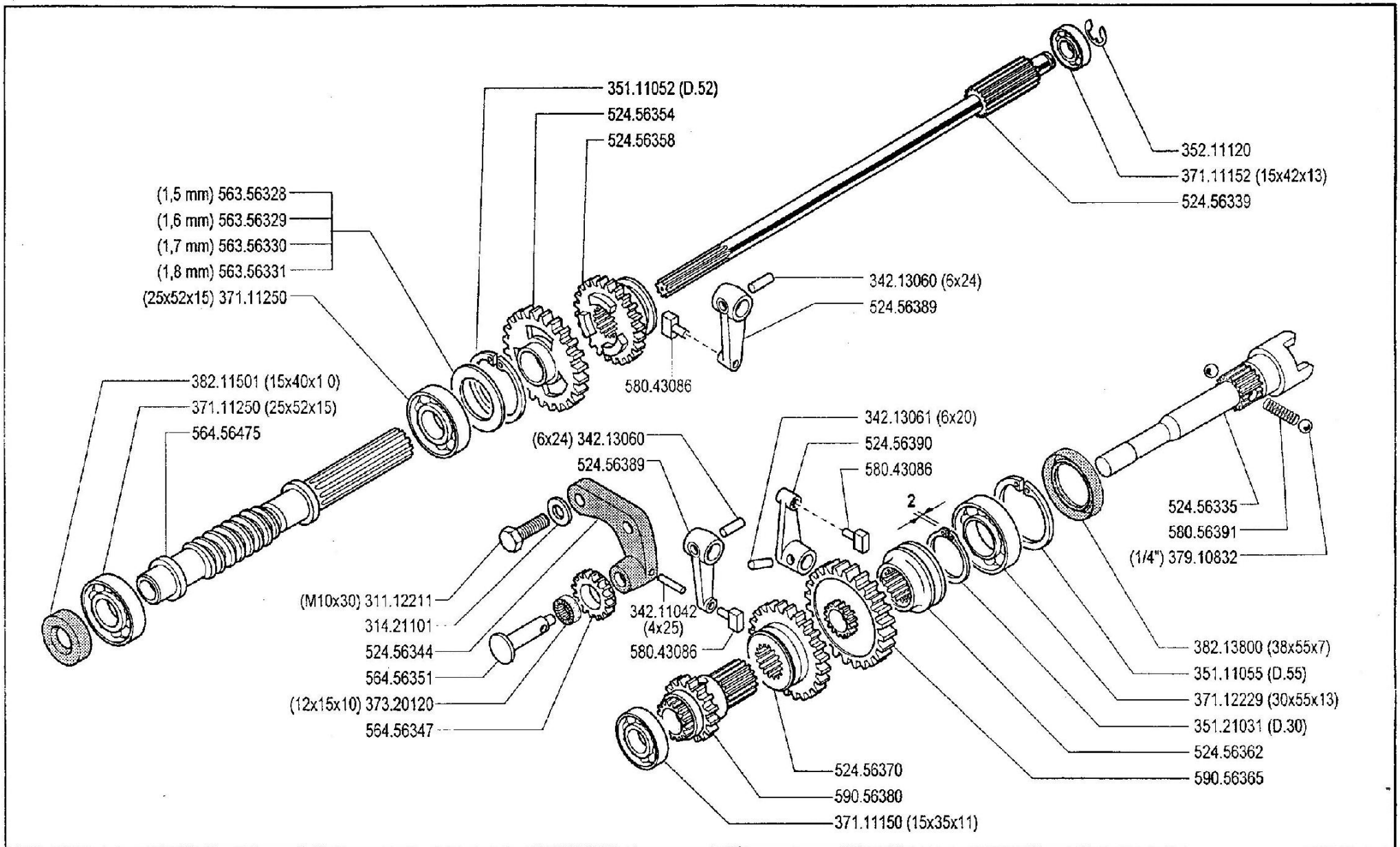

FERRARI

300 serie **95**

INGRANAGGI CAMBIO (320 - 330)

ENGRANAJES
ENGRANAGES

GEARS
ZÄHNRÄDER

DALLA MACCHINA
DE LA MAQUINA
DE LA MACHINE
FROM THE MACHINE
AB DER MASCHINE

N.

05.00

01.06.1995

Pos.	Code	Q.ty	Description	Notes
31112211	31112211	0	SCREW TE M10X30 UNI 5739	
31421101	31421101	0	WASHER	
34211042	34211042	0	ROLL PIN	
34213060	34213060	0	ROLL PIN	
34213061	34213061	0	ROLL PIN	
35111052	35111052	0	SEEGER RING	
35111055	35111055	0	SEEGER RING	
35121031	35121031	0	SEEGER RING	
35211120	35211120	0	SEEGER RING	
37111150	37111150	0	BEARING	
37111152	37111152	0	BEARING	
37111250	37111250	0	BEARING	
37112229	37112229	0	BEARING	
37320120	37320120	0	ROLLER CAGE 12X15/10	
37910832	37910832	0	BALL 1/4	
38211501	38211501	0	OIL SEAL 15X40X10	
38213800	38213800	0	OIL SEAL 38X55X7	
52456335	52456335	0	PTO SHAFT	
52456339	52456339	0	SHAFT	
52456344	52456344	0	GEAR SUPPORT	
52456354	52456354	0	GEAR	
52456358	52456358	0	SLIDER	
52456362	52456362	0	COUPLING	
52456370	52456370	0	SLIDER	
52456389	52456389	0	LEVER	
52456390	52456390	0	LEVER	
56356328	56356328	0	ADJUSTING RING SP=1,5	
56356329	56356329	0	ADJUSTING RING SP=1,6	
56356330	56356330	0	ADJUSTING RING SP=1,7	
56356331	56356331	0	ADJUSTING RING SP=1,8	
56456347	56456347	0	GEAR	
56456351	56456351	0	GEAR PIN	
56456475	56456475	0	SCREW	
58043086	58043086	0	SHOE	

SERIAL

005_00 - GEARS (320-330)

CODE REV

005_0_10769

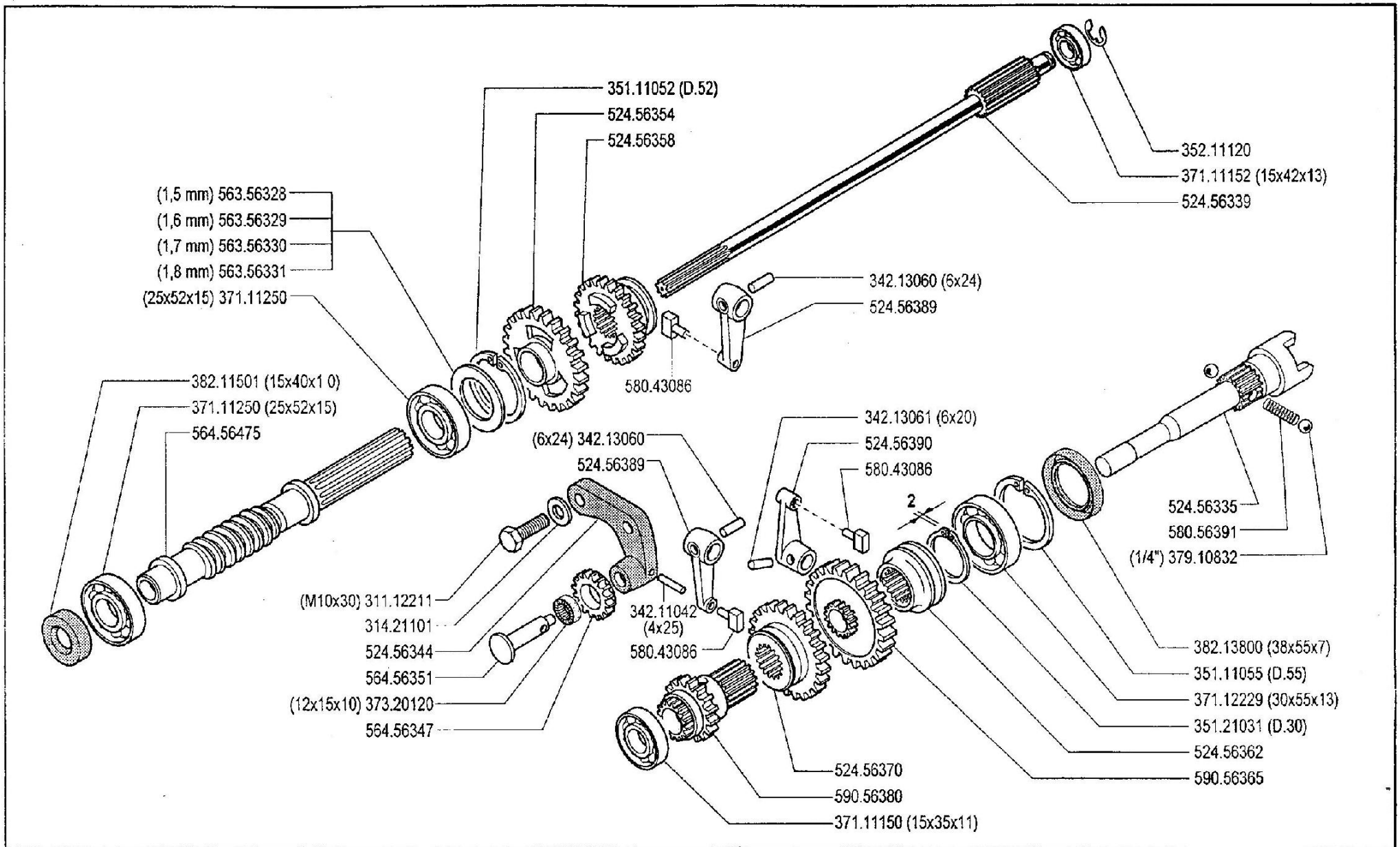

FERRARI

300 serie **95**

INGRANAGGI CAMBIO (320 - 330)

ENGRANAJES
ENGRANAGES

GEARS
ZÄHRÄDER

DALLA MACCHINA
DE LA MAQUINA
DE LA MACHINE
FROM THE MACHINE
AB DER MASCHINE

N.

05.00

01.06.1995

Pos.	Code	Q.ty	Description	Notes
58056391	58056391	0	SPRING	
59056365	59056365	0	PTO GEAR	
59056380	59056380	0	DOUBLE GEAR	

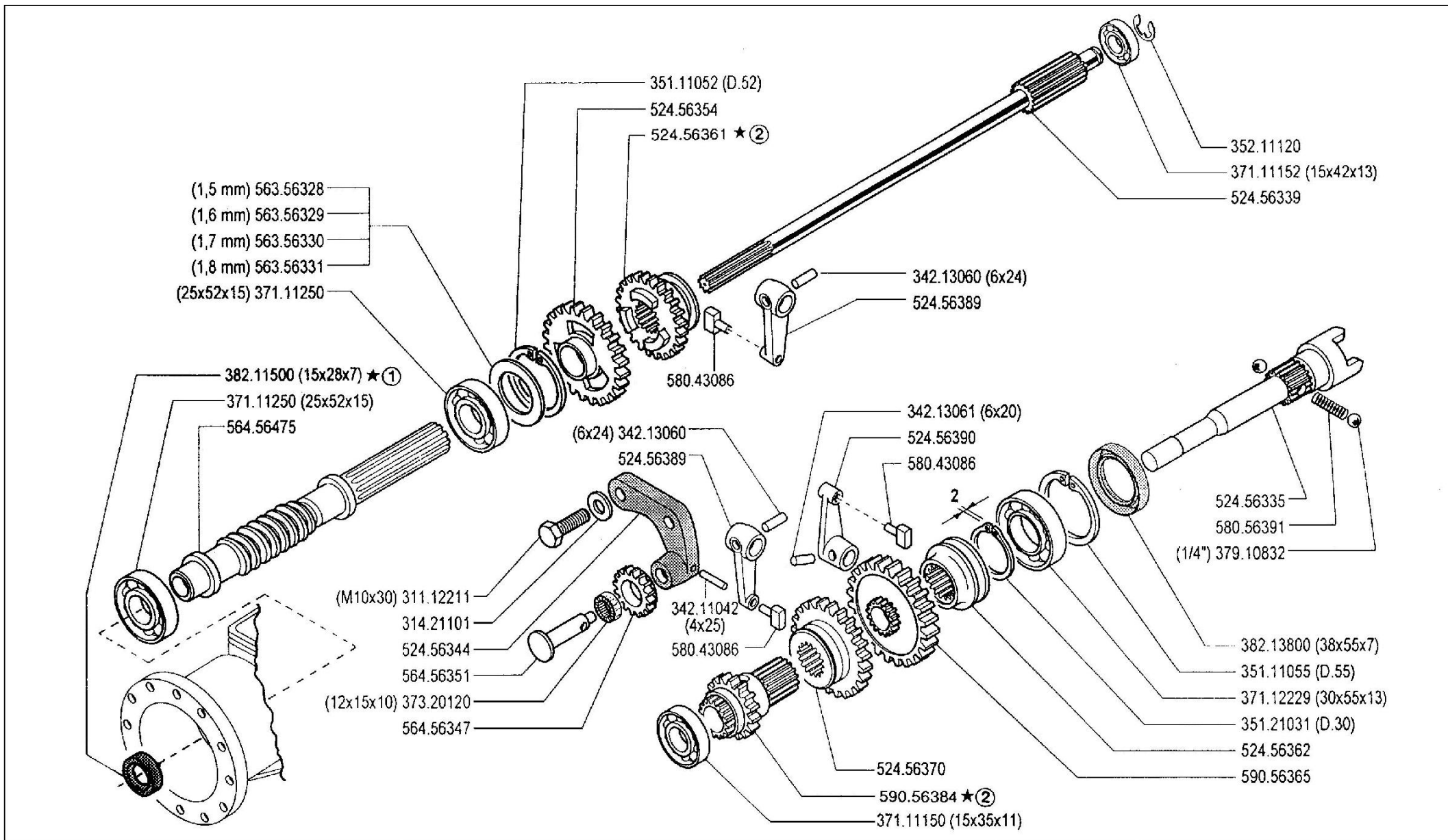

	300 serie 95	INGRANAGGI CAMBIO (320-330)		DALLA MACCHINA DE LA MAQUINA DE LA MACHINE FROM THE MACHINE AB DER MASCHINE	② 202292 (330) ② 109998 (320) ① 201782 (330) ① 108090 (320)	05	01
		GEARS ENGRANAJES	ENGRANAGES ZÄHRÄDER				

Pos.	Code	Q.ty	Description	Notes
31112211	31112211	0	SCREW TE M10X30 UNI 5739	
31421101	31421101	0	WASHER	
34211042	34211042	0	ROLL PIN	
34213060	34213060	0	ROLL PIN	
34213061	34213061	0	ROLL PIN	
35111052	35111052	0	SEEGER RING	
35111055	35111055	0	SEEGER RING	
35121031	35121031	0	SEEGER RING	
35211120	35211120	0	SEEGER RING	
37111150	37111150	0	BEARING	
37111152	37111152	0	BEARING	
37111250	37111250	0	BEARING	
37112229	37112229	0	BEARING	
37320120	37320120	0	ROLLER CAGE 12X15/10	
37910832	37910832	0	BALL 1/4	
38211500	38211500	0	OIL SEAL 15X28X7	
38213800	38213800	0	OIL SEAL 38X55X7	
52456335	52456335	0	PTO SHAFT	
52456339	52456339	0	SHAFT	
52456344	52456344	0	GEAR SUPPORT	
52456354	52456354	0	GEAR	
52456361	52456361	0	SLIDER	
52456362	52456362	0	COUPLING	
52456370	52456370	0	SLIDER	
52456389	52456389	0	LEVER	
52456390	52456390	0	LEVER	
56356328	56356328	0	ADJUSTING RING SP=1,5	
56356329	56356329	0	ADJUSTING RING SP=1,6	
56356330	56356330	0	ADJUSTING RING SP=1,7	
56356331	56356331	0	ADJUSTING RING SP=1,8	
56456347	56456347	0	GEAR	
56456351	56456351	0	GEAR PIN	
56456475	56456475	0	SCREW	
58043086	58043086	0	SHOE	

SERIAL

005_01 - GEARS (320-330)

CODE REV

005_1_10807

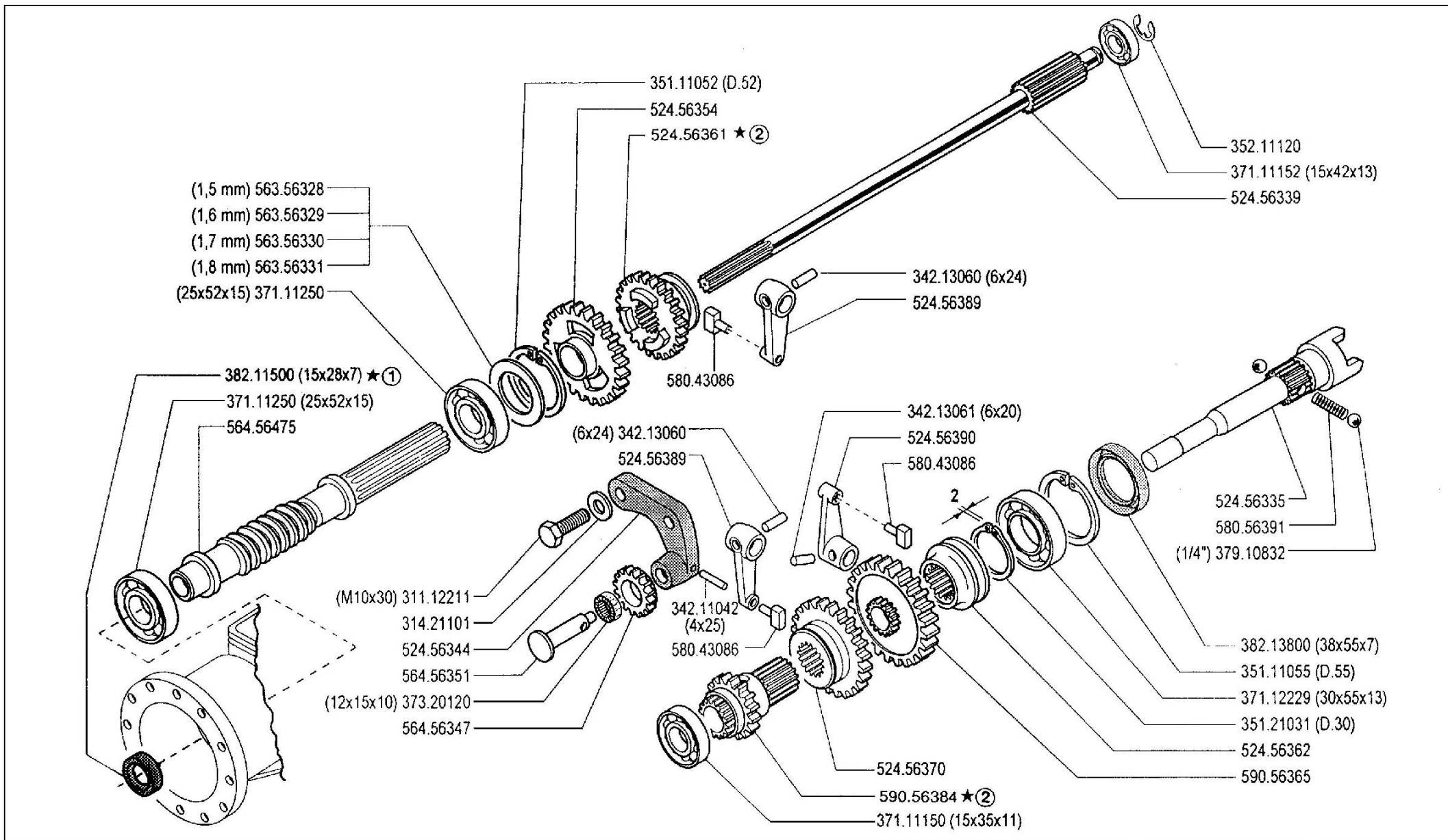

	300 serie 95	INGRANAGGI CAMBIO (320-330)		DALLA MACCHINA DE LA MAQUINA DE LA MACHINE FROM THE MACHINE AB DER MASCHINE	② 202292 (330) ② 109998 (320) ① 201782 (330) ① 108090 (320)	05	01
		GEARS ENGRANAJES	ENGRANAGES ZÄHRÄDER				

Pos.	Code	Q.ty	Description	Notes
58056391	58056391	0	SPRING	
59056365	59056365	0	PTO GEAR	
59056384	59056384	0	DOUBLE GEAR	

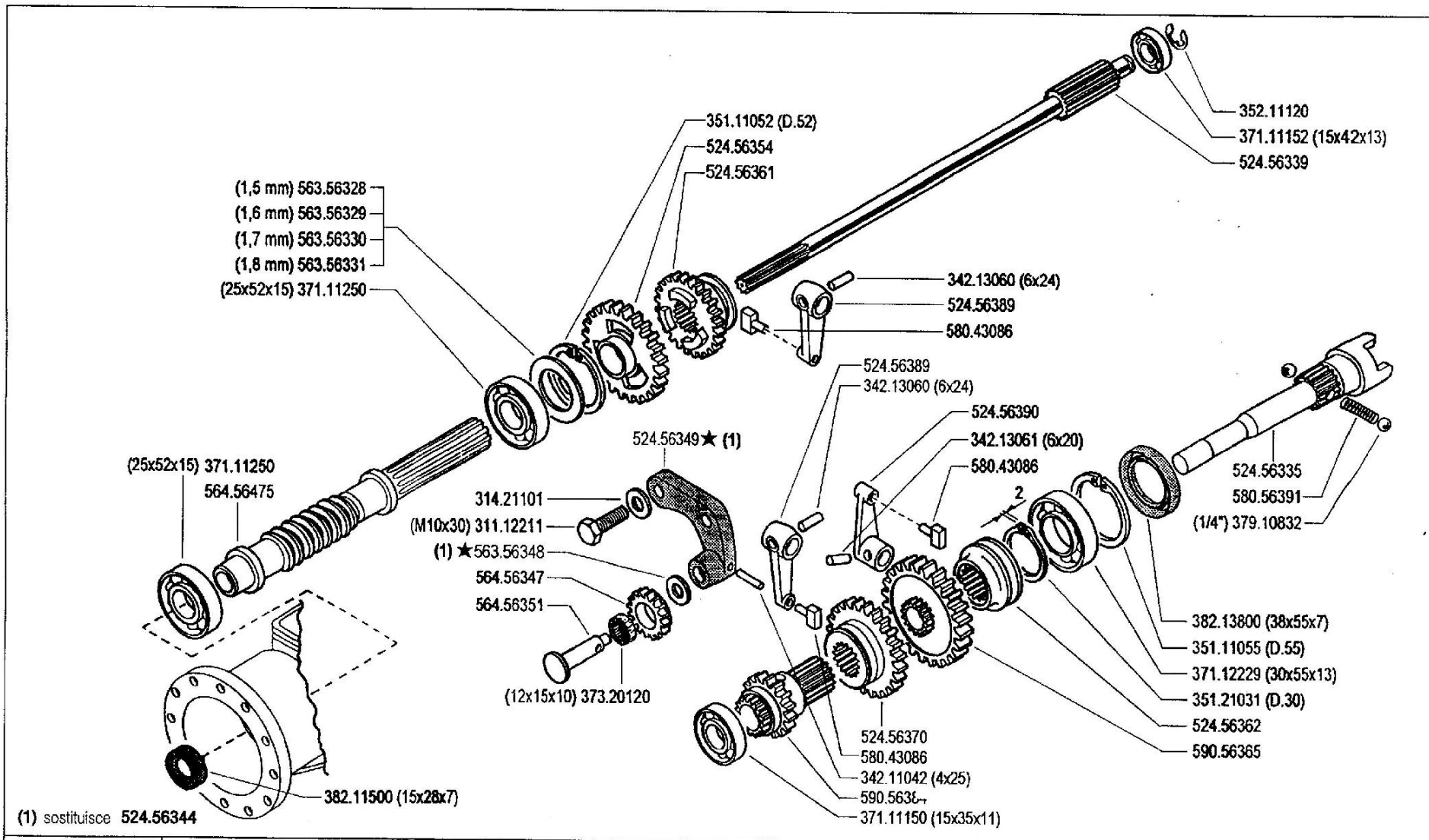

FERRARI

300 serie **95**

INGRANAGGI CAMBIO (320-330)

GEARS
ENGRANAJES

ENGRANAGES
ZÄHNRÄDER

DALLA MACCHINA
DE LA MAQUINA
DE LA MACHINE
FROM THE MACHINE
AB DER MASCHINE

AGGIORNAMENTO
REVISION
MISE A JOUR
APLAZAMIENTO
ANPASSUNG

05

Rev.
2

9/2000

★N

RENNE

Pos.	Code	Q.ty	Description	Notes
31112211	31112211	0	SCREW TE M10X30 UNI 5739	
31421101	31421101	0	WASHER	
34211042	34211042	0	ROLL PIN	
34213060	34213060	0	ROLL PIN	
34213061	34213061	0	ROLL PIN	
35111052	35111052	0	SEEGER RING	
35111055	35111055	0	SEEGER RING	
35121031	35121031	0	SEEGER RING	
35211120	35211120	0	SEEGER RING	
37111150	37111150	0	BEARING	
37111152	37111152	0	BEARING	
37111250	37111250	0	BEARING	
37112229	37112229	0	BEARING	
37320120	37320120	0	ROLLER CAGE 12X15/10	
37910832	37910832	0	BALL 1/4	
38211500	38211500	0	OIL SEAL 15X28X7	
38213800	38213800	0	OIL SEAL 38X55X7	
52456335	52456335	0	PTO SHAFT	
52456339	52456339	0	SHAFT	
52456349	52456349	0	GEAR SUPPORT	
52456354	52456354	0	GEAR	
52456361	52456361	0	SLIDER	
52456362	52456362	0	COUPLING	
52456370	52456370	0	SLIDER	
52456389	52456389	0	LEVER	
52456390	52456390	0	LEVER	
56356328	56356328	0	ADJUSTING RING SP=1,5	
56356329	56356329	0	ADJUSTING RING SP=1,6	
56356330	56356330	0	ADJUSTING RING SP=1,7	
56356331	56356331	0	ADJUSTING RING SP=1,8	
56356348	56356348	0	ADJUSTING RING	
56456347	56456347	0	GEAR	
56456351	56456351	0	GEAR PIN	
56456475	56456475	0	SCREW	

SERIAL

005_02 - GEARS (320-330)

CODE REV

005_2_10845

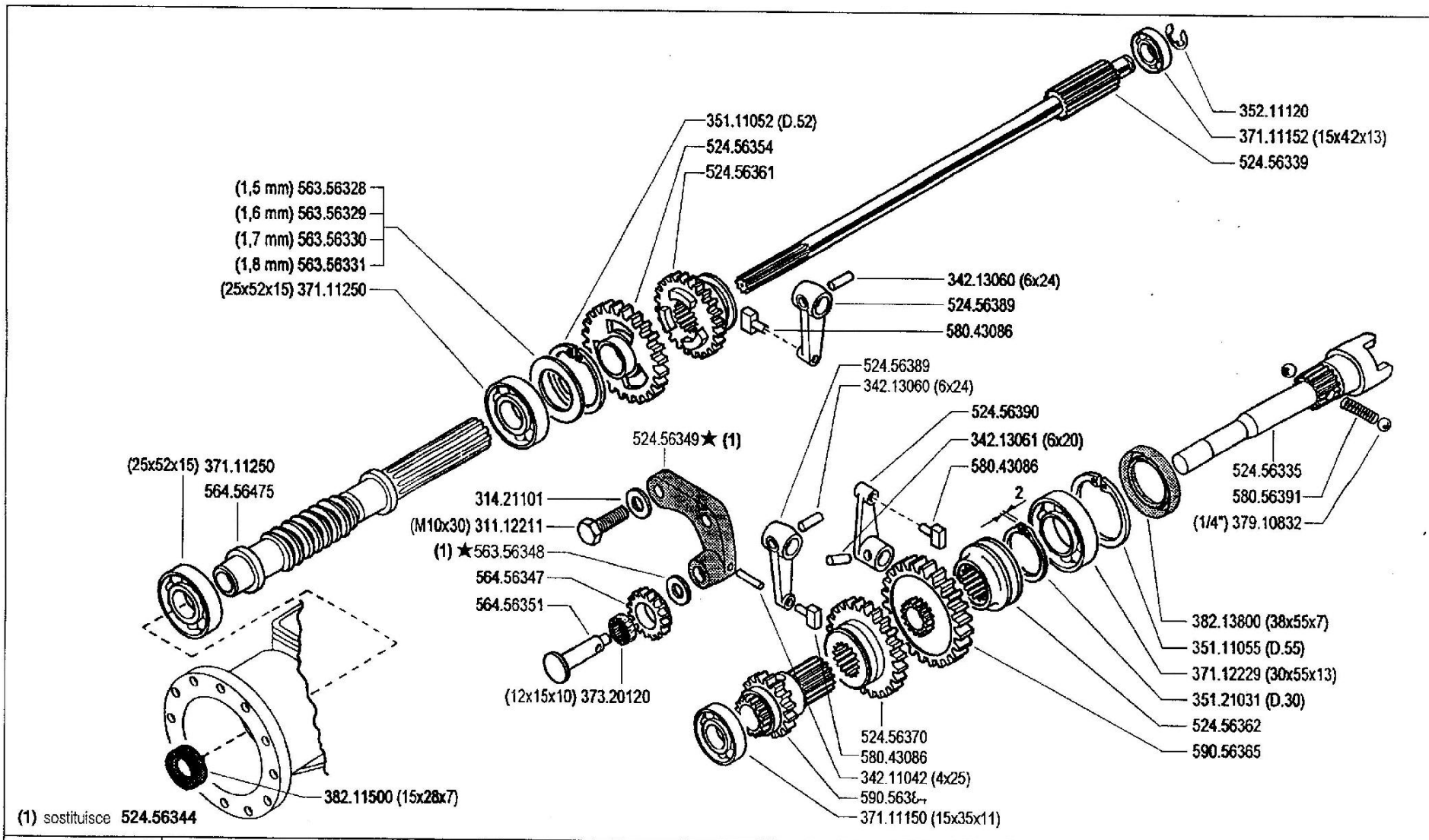

FERRARI

300 serie **95**

INGRANAGGI CAMBIO (320-330)

GEARS
ENGRANAJES

ENGRANAGES
ZÄHNRÄDER

DALLA MACCHINA
DE LA MAQUINA
DE LA MACHINE
FROM THE MACHINE
AB DER MASCHINE

AGGIORNAMENTO
REVISION
MISE A JOUR
APLAZAMIENTO
ANPASSUNG

05

Rev.
2

★N

9/2000

RENNE

Pos.	Code	Q.ty	Description	Notes
58043086	58043086	0	SHOE	
58056391	58056391	0	SPRING	
59056365	59056365	0	PTO GEAR	
59056384	59056384	0	DOUBLE GEAR	

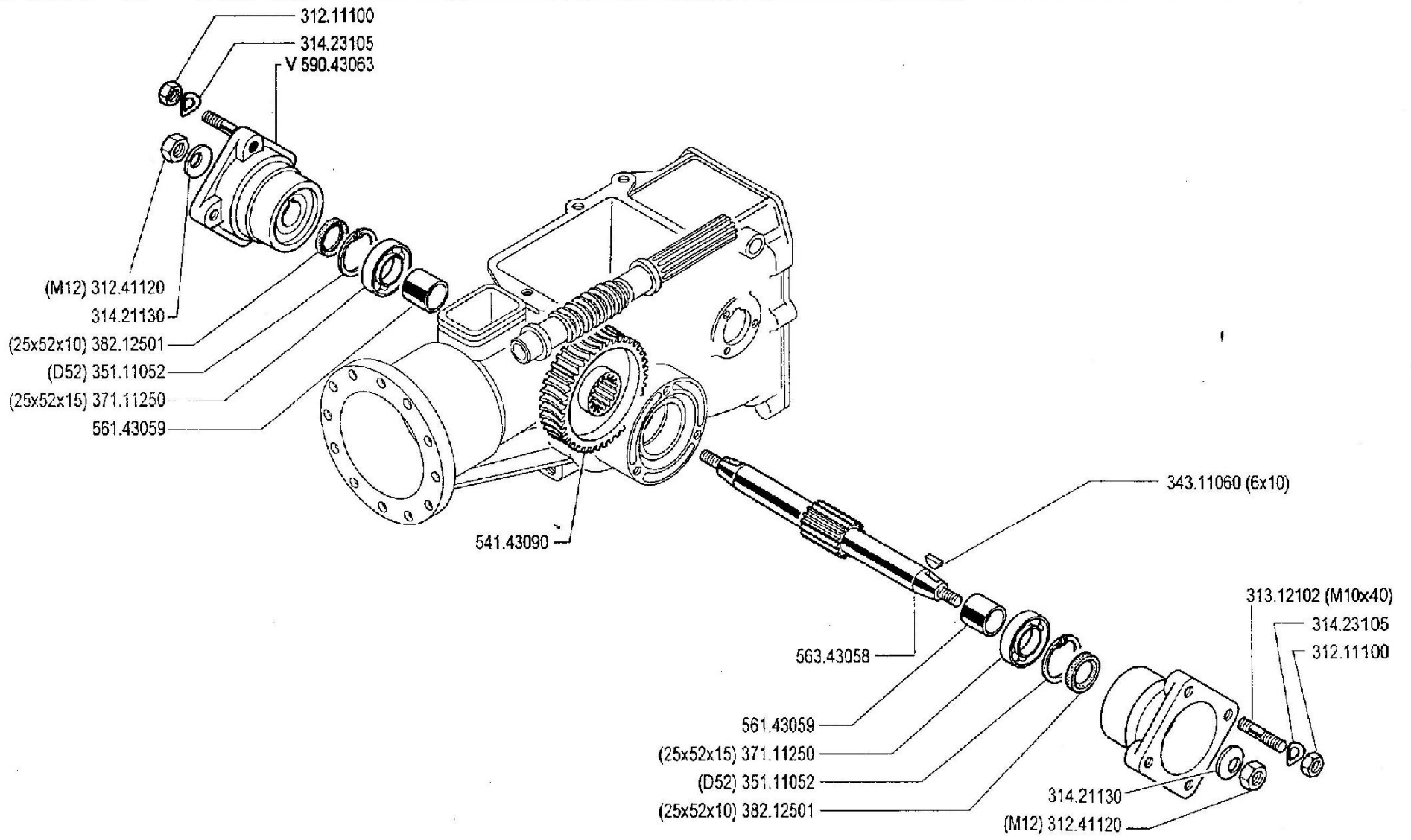

V = verde - vert - green - grün

FERRARI

300 serie **95**

ASSE RUOTE (320)

EJE RUEDAS
 ESSIEU ROUES

WHEEL AXLE
 RADACHSE

DALLA MACCHINA
 DE LA MAQUINA
 DE LA MACHINE
 FROM THE MACHINE
 AB DER MASCHINE

N.

07.00

01.06.1995

Pos.	Code	Q.ty	Description	Notes
31211100	31211100	0	NUT M10	
31241120	31241120	0	SELFLOCK NUT M12	
31312102	31312102	0	STUD BOLT M10X40X24X12	
31421130	31421130	0	WASHER	
31423105	31423105	0	SPRING WASHER 10,5	
34311060	34311060	0	KEY 6X10 UNI 6606	
35111052	35111052	0	SEEGER RING	
37111250	37111250	0	BEARING	
38212501	38212501	0	OIL SEAL 25X52X10	
54143090	54143090	0	CROWN WHEEL	
56143059	56143059	0	SPACER	
56343058	56343058	0	AXLE SHAFT	
59043063	59043063	0	WHEEL HUB	

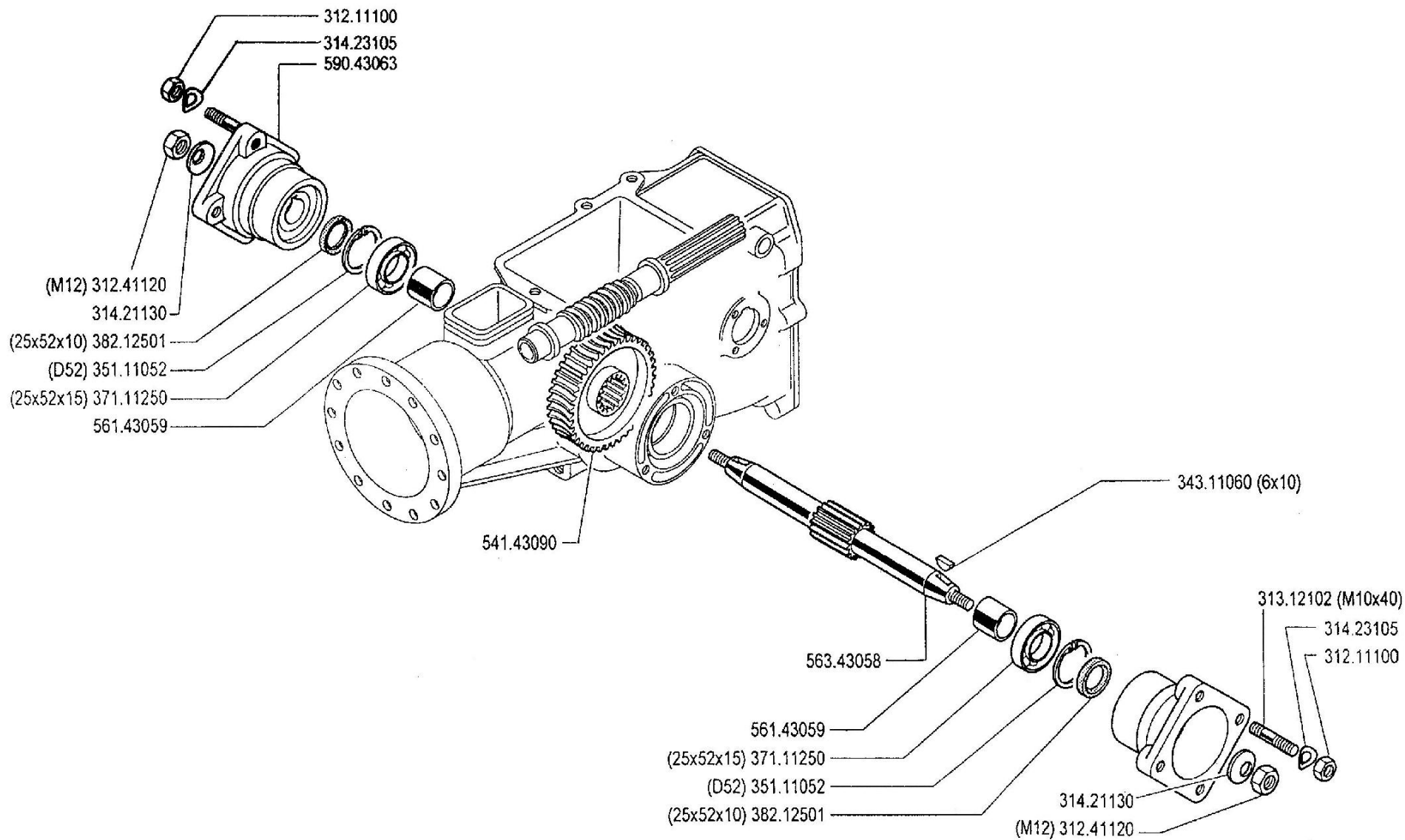

FERRARI

300 serie **95**

ASSE RUOTE (310★ -320)

WHEELS AXLE
EJE RUEDAS

ESSIEU ROUES
RADACHSE

DALLA MACCHINA
DE LA MAQUINA
DE LA MACHINE
FROM THE MACHINE
AB DER MASCHINE

AGGIORNAMENTO

REVISION

MISE A JOUR

APLAZAMIENTO

ANPASSUNG

07

01

9/1997

★N.

Pos.	Code	Q.ty	Description	Notes
31211100	31211100	0	NUT M10	
31241120	31241120	0	SELFLOCK NUT M12	
31312102	31312102	0	STUD BOLT M10X40X24X12	
31421130	31421130	0	WASHER	
31423105	31423105	0	SPRING WASHER 10,5	
34311060	34311060	0	KEY 6X10 UNI 6606	
35111052	35111052	0	SEEGER RING	
37111250	37111250	0	BEARING	
38212501	38212501	0	OIL SEAL 25X52X10	
54143090	54143090	0	CROWN WHEEL	
56143059	56143059	0	SPACER	
56343058	56343058	0	AXLE SHAFT	
59043063	59043063	0	WHEEL HUB	

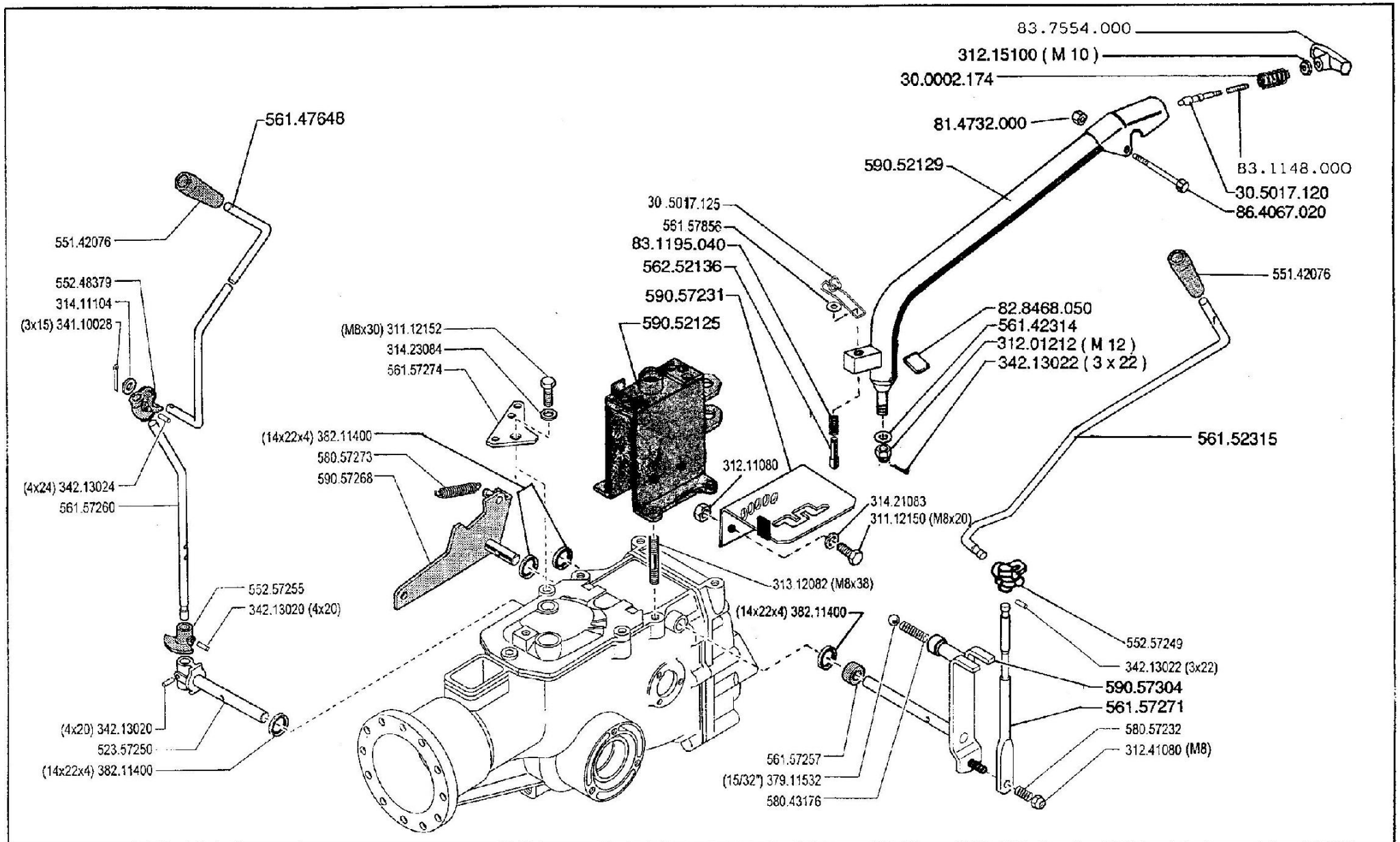

FERRARI

300 serie **95**

COLUMNA
PLANTON

PIANTONE (320 - 330)

STEERING COLUMN
LENKSÄULE

DALLA MACCHINA
DE LA MAQUINA
DE LA MACHINE
FROM THE MACHINE
AB DER MASCHINE

N.

10.00

01.06.1995

Pos.	Code	Q.ty	Description	Notes
31112150	31112150	0	SCREW TE M8X20 UNI 5739 8G	
31112152	31112152	0	SCREW TE M8X30 UNI 5739 8G	
31201212	31201212	0	NUT M12	
31211080	31211080	0	NUT M8	
31215100	31215100	0	NUT M10	
31241080	31241080	0	HEXAGON SELFLOCK NUT M8	
31312082	31312082	0	STUD BOLT M8X38X14X20	
31411104	31411104	0	WASHER 10,5x18	
31421083	31421083	0	WASHER	
31423084	31423084	0	SPRING WASHER 8,4	
34110028	34110028	0	SPLIT PIN	
34213020	34213020	0	ROLL PIN	
34213022	34213022	0	ROLL PIN	
34213024	34213024	0	ROLL PIN	
37911532	37911532	0	BALL 15/32	
38211400	38211400	0	OIL SEAL 14X22X4	
52357250	52357250	0	PIN	
55142076	55142076	0	KNOB	
55248379	55248379	0	JOINT	
55257249	55257249	0	JOINT	
55257255	55257255	0	STOP	
56142314	56142314	0	WASHER 12,5x34/4	
56147648	56147648	0	PULL ROD	
56152315	56152315	0	GEARSHIFT ROD	
56157257	56157257	0	SPACER	
56157260	56157260	0	PTO LEVER	
56157271	56157271	0	COMMAND LEVER	
56157274	56157274	0	SQUARE	
56157856	56157856	0	WASHER 12,5x30/2,5	
56252136	56252136	0	LOCKING BOLT	
58043176	58043176	0	SPRING	
58057232	58057232	0	SPRING	
58057273	58057273	0	SPRING	
59052125	59052125	0	SUPPORT	

SERIAL

010_00 - STEERING COLUMN

CODE REV

010_0_11134

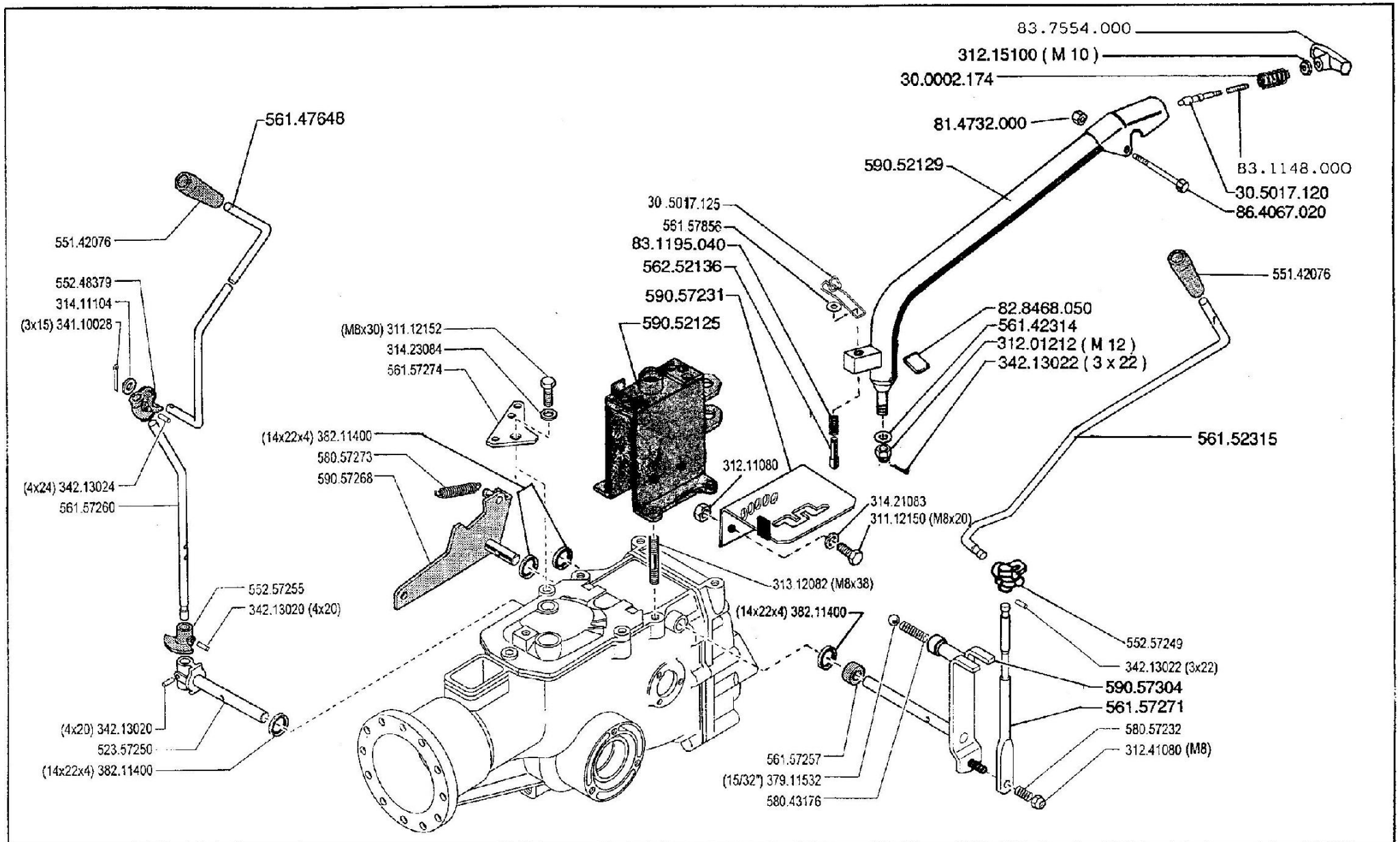

FERRARI

300 serie **95**

COLUMNA
PLANTON

PIANTONE (320 - 330)

STEERING COLUMN
LENKSÄULE

DALLA MACCHINA
DE LA MAQUINA
DE LA MACHINE
FROM THE MACHINE
AB DER MASCHINE

N.

10.00

01.06.1995

Pos.	Code	Q.ty	Description	Notes
59052129	59052129	0	COLUMN	
59057231	59057231	0	GEAR SELECTOR	
59057268	59057268	0	LEVER	
59057304	59057304	0	GEAR LEVER	
F0300002	F0300002174	0	BELLOWS	
F0305017	F0305017120	0	STAKE	
F0305017	F0305017125	0	COMMAND LEVER	
F0814732	F0814732000	0	NUT M12X1,5	
F0828468	F0828468050	0	GRIP	
F0831148	F0831148000	0	SPRING DM.12,5X45	
F0831195	F0831195040	0	SPRING DM.15X2,5/32	
F0837554	F0837554000	0	GRIP	
F0864067	F0864067020	0	SCREW M12X1,5/70 SPECIAL	

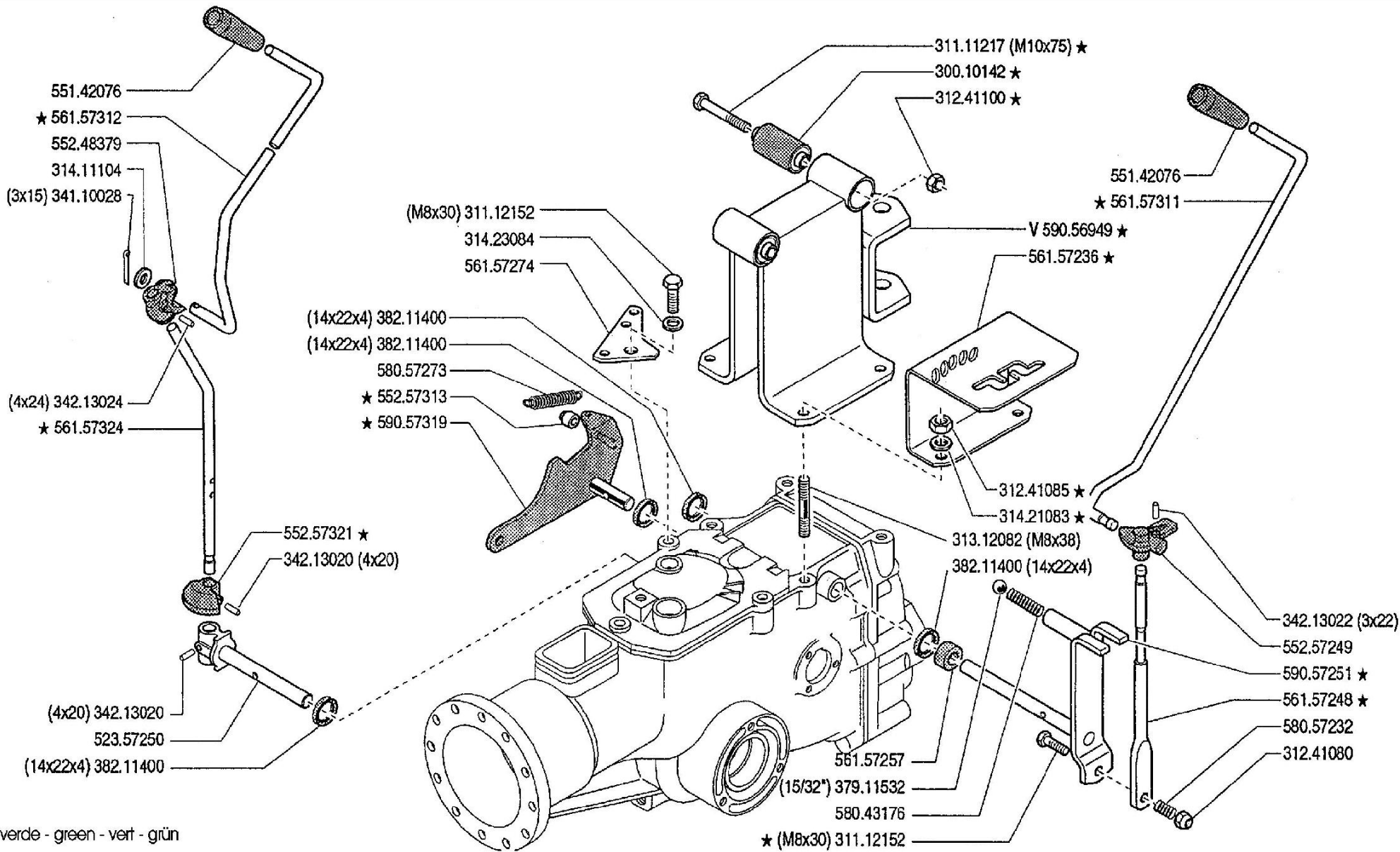

V = verde - green - vert - grün

FERRARI

300 serie **95**

COMANDI (320-330)

CONTROLS
MANDOS

COMMANDES
ANTRIEBE

DALLA MACCHINA
DE LA MAQUINA
DE LA MACHINE
FROM THE MACHINE
AB DER MASCHINE

★N.

202978 (330)

112717 (320)

10 01

11/1996

Vncd

ZENITE

Pos.	Code	Q.ty	Description	Notes
30010142	30010142	0	SILENT-BLOCK 10,2X30X45X49	
31111217	31111217	0	SCREW TE M10X75 UNI 5737 8G	
31112152	31112152	0	SCREW TE M8X30 UNI 5739 8G	
31241080	31241080	0	HEXAGON SELFLOCK NUT M8	
31241085	31241085	0	SELFLOCK NUT M8 6S	
31241100	31241100	0	SELFLOCK HEXAGON NUT M10	
31312082	31312082	0	STUD BOLT M8X38X14X20	
31411104	31411104	0	WASHER 10,5x18	
31421083	31421083	0	WASHER	
31423084	31423084	0	SPRING WASHER 8,4	
34110028	34110028	0	SPLIT PIN	
34213020	34213020	0	ROLL PIN	
34213022	34213022	0	ROLL PIN	
34213024	34213024	0	ROLL PIN	
37911532	37911532	0	BALL 15/32	
38211400	38211400	0	OIL SEAL 14X22X4	
52357250	52357250	0	PIN	
55142076	55142076	0	KNOB	
55248379	55248379	0	JOINT	
55257249	55257249	0	JOINT	
55257313	55257313	0	ROLLER	
55257321	55257321	0	STOP	
56157236	56157236	0	GEAR SELECTOR	
56157248	56157248	0	COMMAND LEVER	
56157257	56157257	0	SPACER	
56157274	56157274	0	SQUARE	
56157311	56157311	0	GEARSHIFT ROD	
56157312	56157312	0	ROD	
56157324	56157324	0	PTO LEVER	
58043176	58043176	0	SPRING	
58057232	58057232	0	SPRING	
58057273	58057273	0	SPRING	
59056949	59056949	0	SUPPORT	
59057251	59057251	0	GEAR LEVER	

SERIAL

010_01 - CONTROLS (320-330)

Version: MC 320, MC 330

CODE REV

010_1_11182

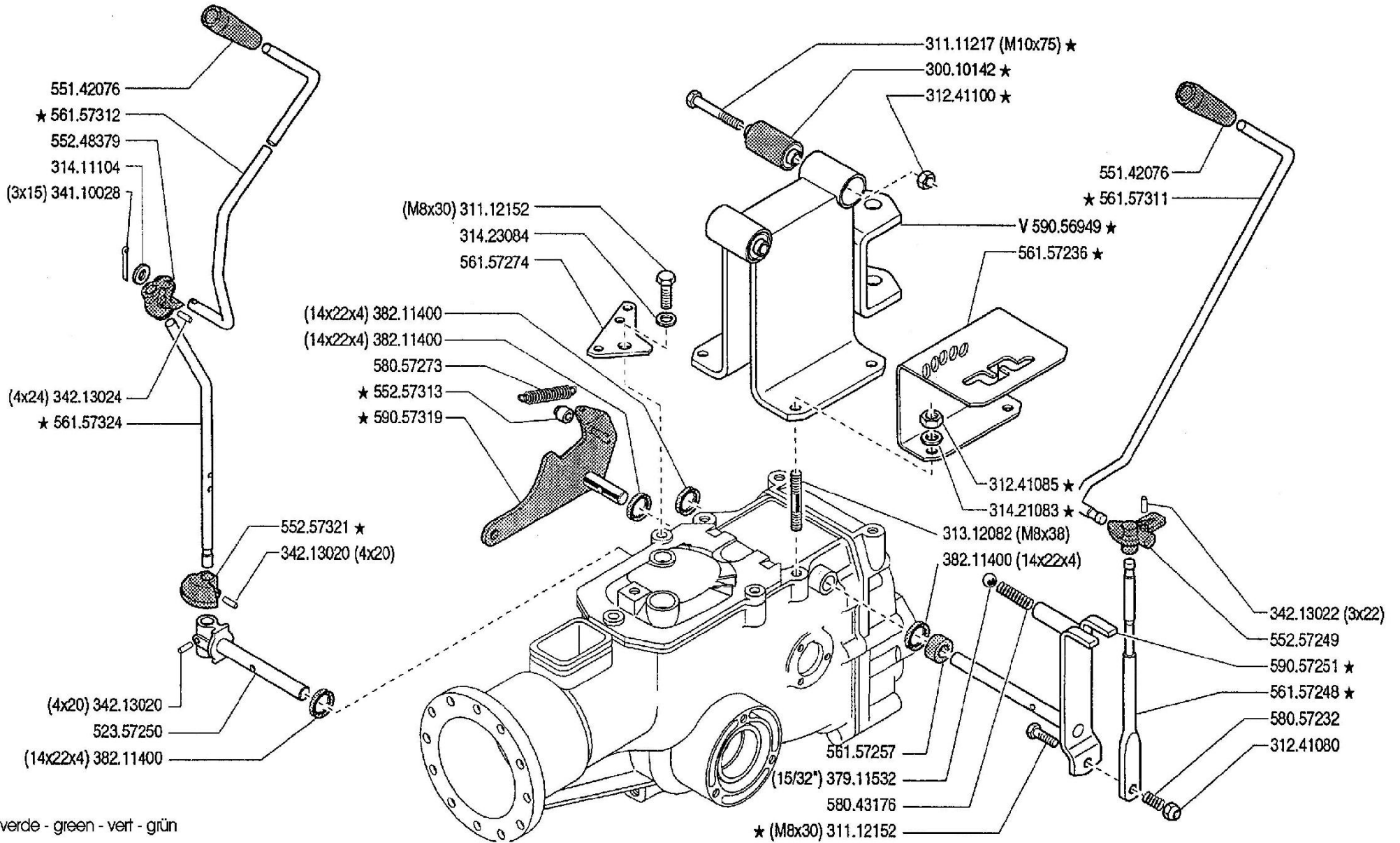

V = verde - green - vert - grün

FERRARI

300 serie **95**

COMANDI (320-330)

CONTROLS
MANDOS

COMMANDES
ANTRIEBE

DALLA MACCHINA
DE LA MAQUINA
DE LA MACHINE
FROM THE MACHINE
AB DER MASCHINE

★N.

202978 (330)

112717 (320)

10 01

11/1996

ZENITE

Pos.	Code	Q.ty	Description	Notes
59057319	59057319	0	LEVER	

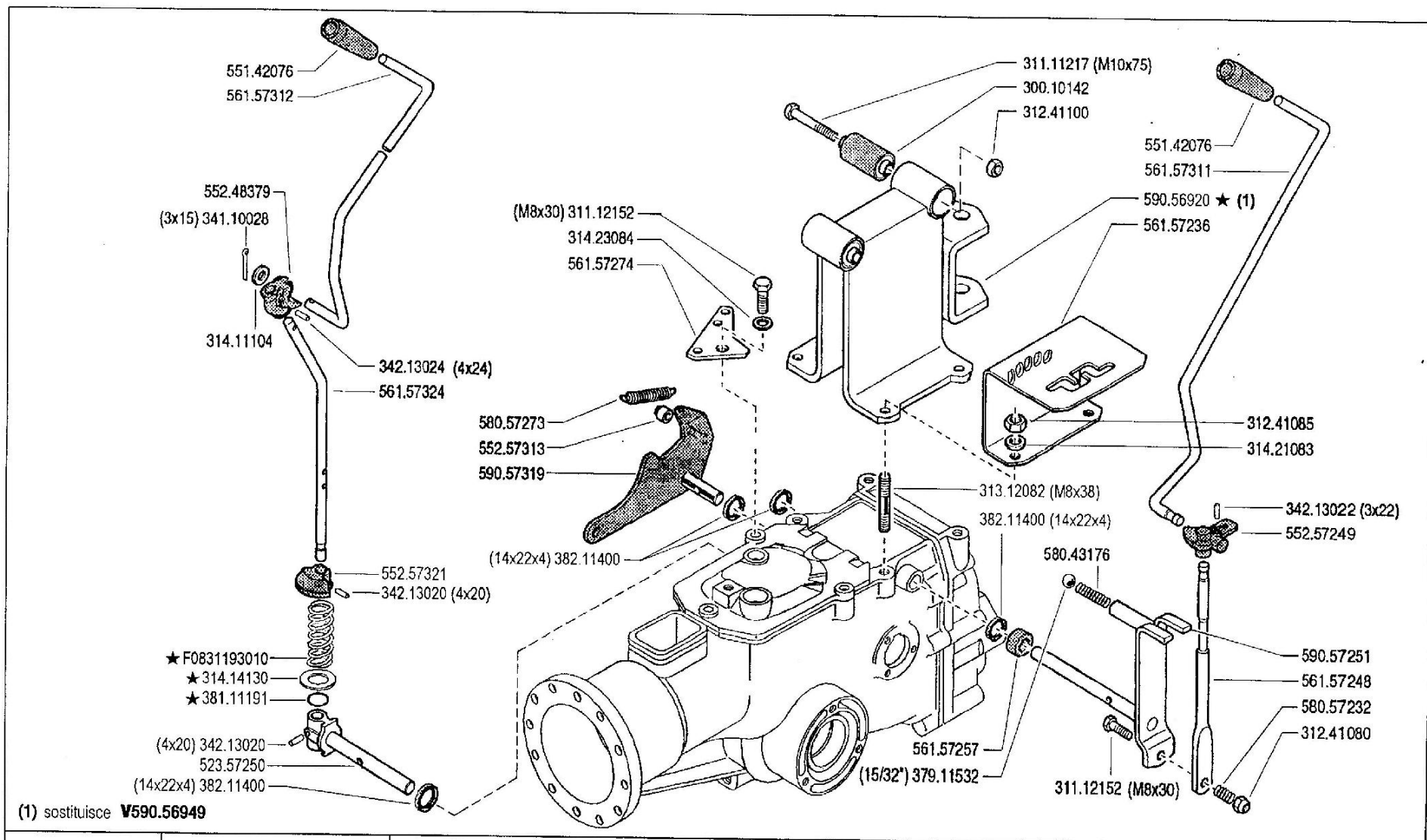

	300 serie 95	COMANDI (320-330) CONTROLS MANDOS COMMANDES ANTRIEBE	DALLA MACCHINA DE LA MAQUINA DE LA MACHINE FROM THE MACHINE AB DER MASCHINE	AGGIORNAMENTO REVISION MISE A JOUR APLAZAMIENTO ANPASSUNG	Rev. 2
			★ N.	10 1/2003	

FERRARI

Pos.	Code	Q.ty	Description	Notes
30010142	30010142	0	SILENT-BLOCK 10,2X30X45X49	
31111217	31111217	0	SCREW TE M10X75 UNI 5737 8G	
31112152	31112152	0	SCREW TE M8X30 UNI 5739 8G	
31241080	31241080	0	HEXAGON SELFLOCK NUT M8	
31241085	31241085	0	SELFLOCK NUT M8 6S	
31241100	31241100	0	SELFLOCK HEXAGON NUT M10	
31312082	31312082	0	STUD BOLT M8X38X14X20	
31411104	31411104	0	WASHER 10,5x18	
31414130	31414130	0	WASHER 13	
31421083	31421083	0	WASHER	
31423084	31423084	0	SPRING WASHER 8,4	
34110028	34110028	0	SPLIT PIN	
34213020	34213020	0	ROLL PIN	
34213022	34213022	0	ROLL PIN	
34213024	34213024	0	ROLL PIN	
37911532	37911532	0	BALL 15/32	
38111191	38111191	0	O-RING	
38211400	38211400	0	OIL SEAL 14X22X4	
52357250	52357250	0	PIN	
55142076	55142076	0	KNOB	
55248379	55248379	0	JOINT	
55257249	55257249	0	JOINT	
55257313	55257313	0	ROLLER	
55257321	55257321	0	STOP	
56157236	56157236	0	GEAR SELECTOR	
56157248	56157248	0	COMMAND LEVER	
56157257	56157257	0	SPACER	
56157274	56157274	0	SQUARE	
56157311	56157311	0	GEARSHIFT ROD	
56157312	56157312	0	ROD	
56157324	56157324	0	PTO LEVER	
58043176	58043176	0	SPRING	
58057232	58057232	0	SPRING	
58057273	58057273	0	SPRING	

SERIAL

A010_02 - CONTROLS (320-330)

CODE REV

010_2_11218

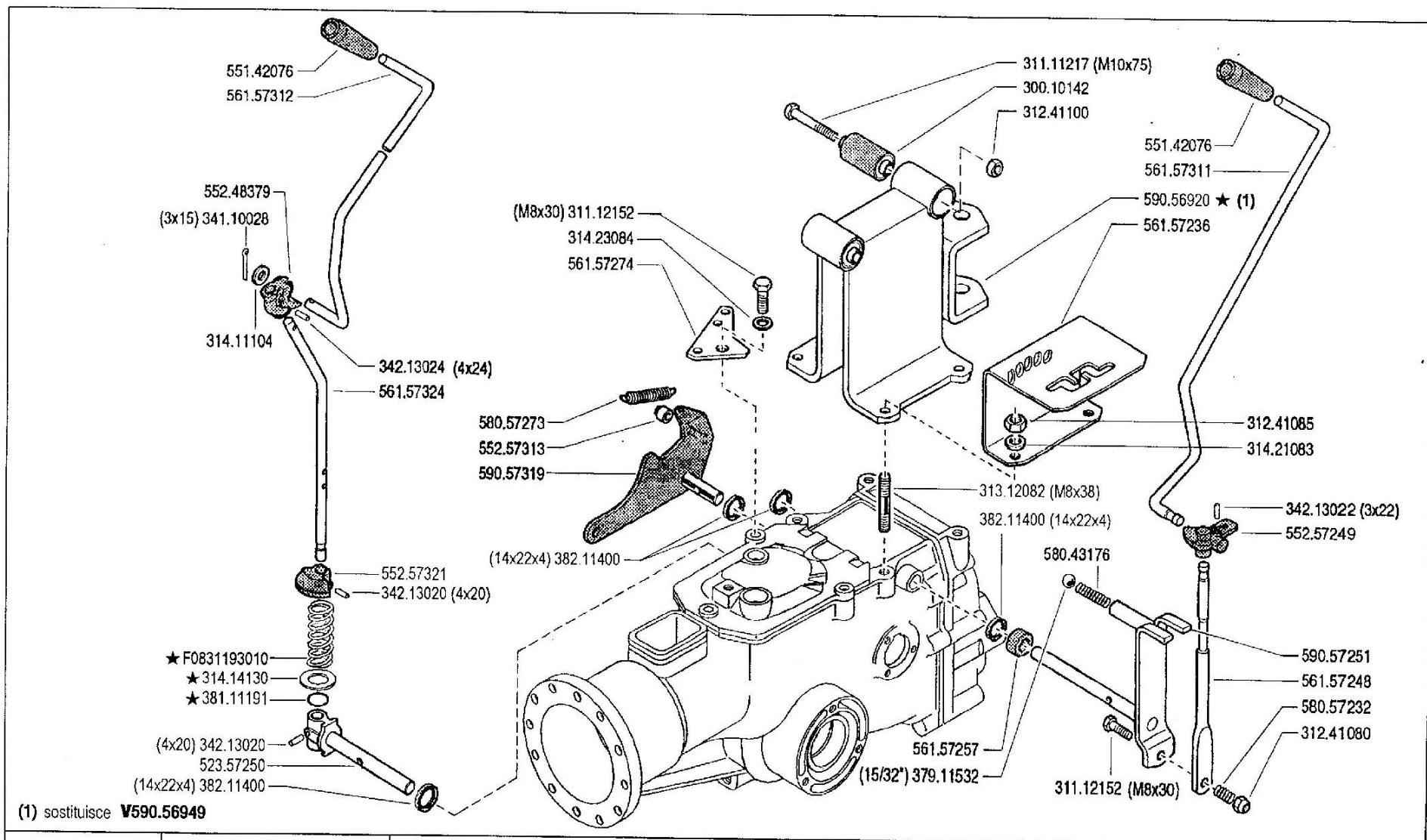

(1) sostituisce V590.56949

	<h1>300</h1> serie 95	CONTROLS MANDOS	COMANDI (320-330)	DALLA MACCHINA DE LA MAQUINA DE LA MACHINE FROM THE MACHINE AB DER MASCHINE	AGGIORNAMENTO	<h1>10</h1>	Rev. <h1>2</h1>
					REVISION		
					MISE A JOUR		
					APLAZAMIENTO		
					ANPASSUNG	<h1>1/2003</h1>	

★ N.

FERRARI

Pos.	Code	Q.ty	Description	Notes
59056920	59056920	0	SUPPORT	
59057251	59057251	0	GEAR LEVER	
59057319	59057319	0	LEVER	
F0831193	F0831193010	0	SPRING DM.15X70	

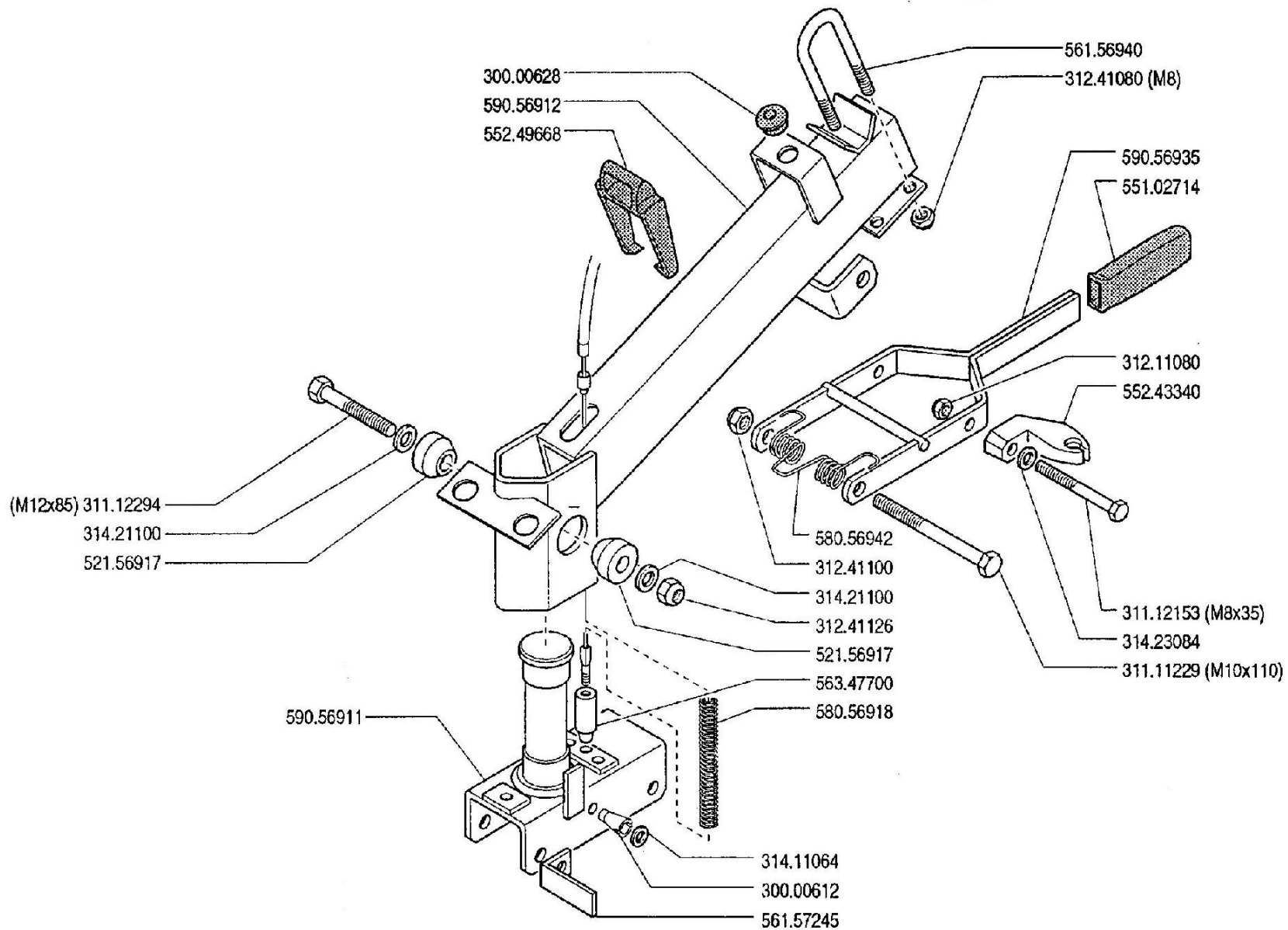

PIANTONE (320 - 330)

FERRARI

300 serie **95**

COLUMNA
PLANTON

STEERING COLUMN
LENKSÄULE

DALLA MACCHINA
DE LA MAQUINA
DE LA MACHINE
FROM THE MACHINE
AB DER MASCHINE

★ N.

202978 (330)
112717 (320)

10/A/00

11.1996

Pos.	Code	Q.ty	Description	Notes
30000612	30000612	0	BLOCK	
30000628	30000628	0	CABLE GLAND 90/200/30	
31111229	31111229	0	SCREW TE M10X110 UNI 5737 8G	
31112153	31112153	0	SCREW TE M8X35 UNI 5739 8G	
31112294	31112294	0	SCREW TE M12X85 UNI 5737	
31211080	31211080	0	NUT M8	
31241080	31241080	0	HEXAGON SELFLOCK NUT M8	
31241100	31241100	0	SELFLOCK HEXAGON NUT M10	
31241126	31241126	0	SELFLOCK NUT M12	
31411064	31411064	0	WASHER 6,4x12,5	
31421100	31421100	0	CUP SPRING	
31423084	31423084	0	SPRING WASHER 8,4	
52156917	52156917	0	WEDGE	
55102714	55102714	0	KNOB	
55243340	55243340	0	SUPPORT	
55249668	55249668	0	PASSING	
56156940	56156940	0	U BOLT	
56157245	56157245	0	LEVER STOP	
56347700	56347700	0	FERRULE	
58056918	58056918	0	SPRING	
58056942	58056942	0	SPRING	
59056911	59056911	0	SUPPORT	
59056912	59056912	0	COLUMN	
59056935	59056935	0	LEVER	

SERIAL

STEERING COLUMN (320-330)

Version: MC 330, MC 320

CODE REV

10A_0_12219

★ 310

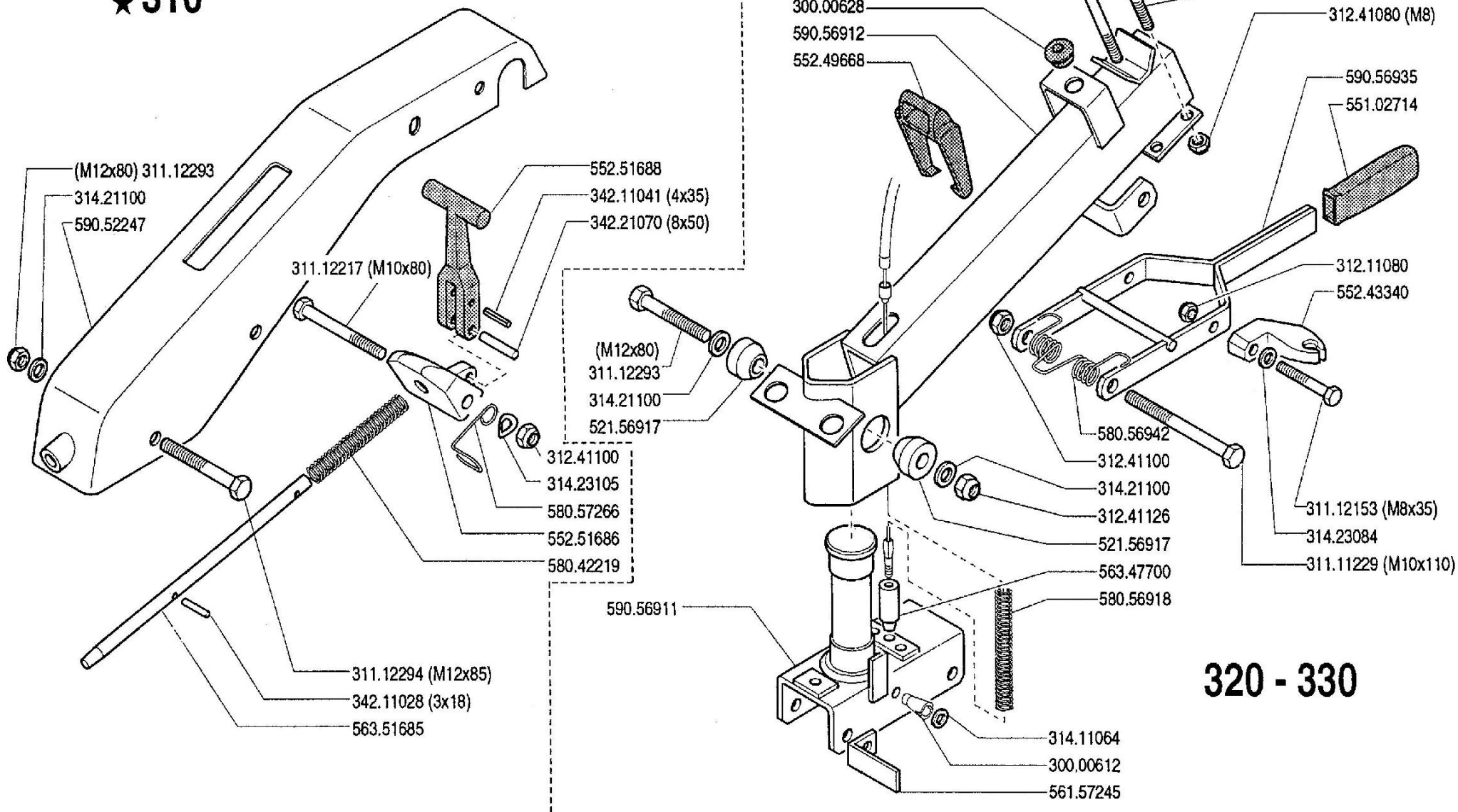

320 - 330

	300 serie 95	PIANTONE (310-320-330) STEERING COLUMN COLUMNA PLANTON LENKSÄULE	DALLA MACCHINA DE LA MAQUINA DE LA MACHINE FROM THE MACHINE AB DER MASCHINE	_____	10 A 01	Vncd _____
				★N.		

Pos.	Code	Q.ty	Description	Notes
30000612	30000612	0	BLOCK	
30000628	30000628	0	CABLE GLAND 90/200/30	
31111229	31111229	0	SCREW TE M10X110 UNI 5737 8G	
31112153	31112153	0	SCREW TE M8X35 UNI 5739 8G	
31112217	31112217	0	SCREW TE M10X80 UNI 5737	
31112293	31112293	0	SCREW TE M12X80 UNI 5737	
31112294	31112294	0	SCREW TE M12X85 UNI 5737	
31211080	31211080	0	NUT M8	
31241080	31241080	0	HEXAGON SELFLOCK NUT M8	
31241100	31241100	0	SELFLOCK HEXAGON NUT M10	
31241126	31241126	0	SELFLOCK NUT M12	
31411064	31411064	0	WASHER 6,4x12,5	
31421100	31421100	0	CUP SPRING	
31423084	31423084	0	SPRING WASHER 8,4	
31423105	31423105	0	SPRING WASHER 10,5	
34211028	34211028	0	ROLL PIN	
34211041	34211041	0	ROLL PIN	
34221070	34221070	0	CYLINDRICAL PLUG 8X50 UNI 1707	
52156917	52156917	0	WEDGE	
55102714	55102714	0	KNOB	
55243340	55243340	0	SUPPORT	
55249668	55249668	0	PASSING	
55251686	55251686	0	LEVER BEARING	
55251688	55251688	0	LEVER	
56156940	56156940	0	U BOLT	
56157245	56157245	0	LEVER STOP	
56347700	56347700	0	FERRULE	
56351685	56351685	0	ROD	
58042219	58042219	0	SPRING	
58056918	58056918	0	SPRING	
58056942	58056942	0	SPRING	
58057266	58057266	0	HOLDER	
59052247	59052247	0	HANDLE BAR COLUMN	
59056911	59056911	0	SUPPORT	

SERIAL

STEERING COLUMN (310-320-330)

CODE REV

10A_1_12244

★ 310

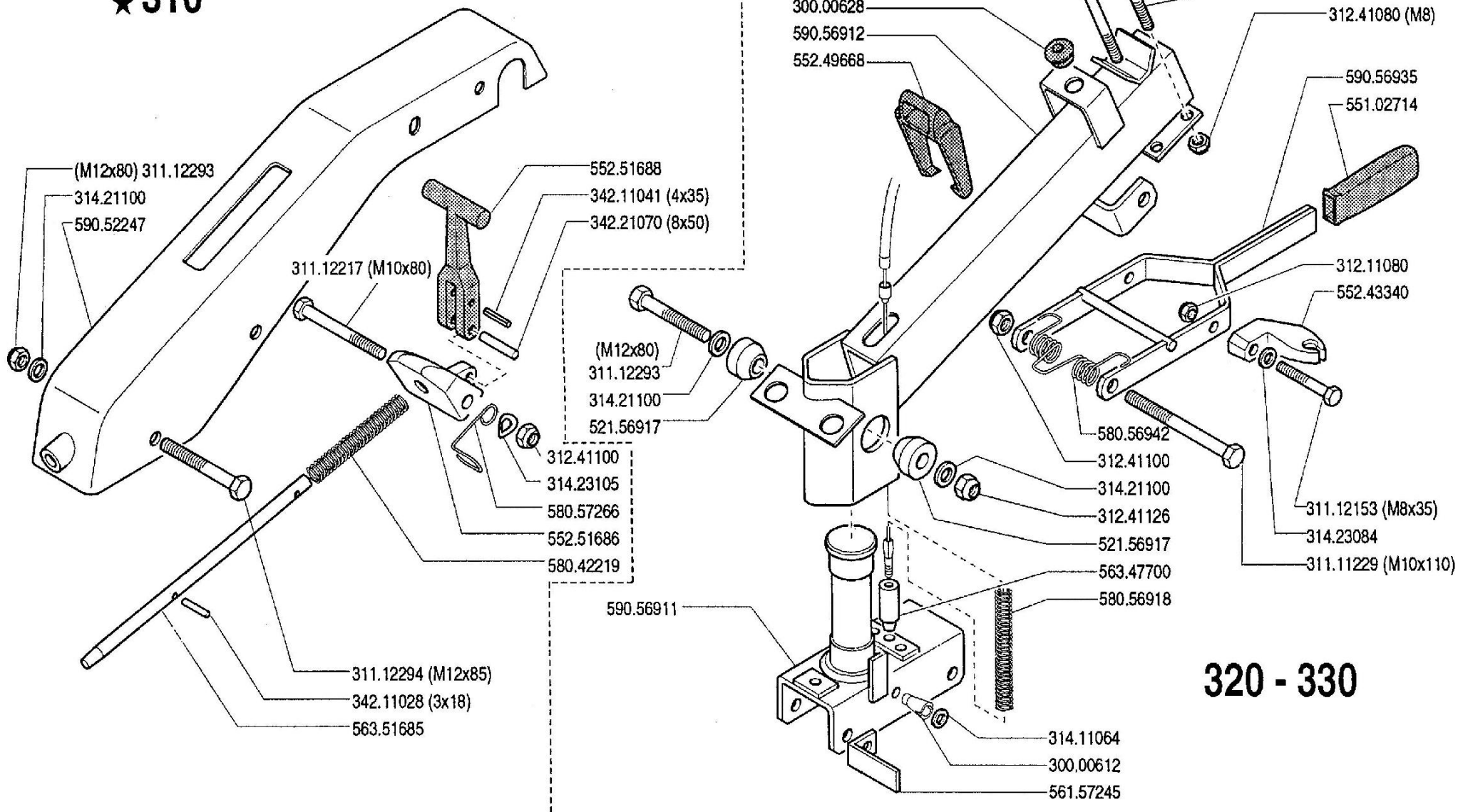

320 - 330

	300 serie 95	PIANTONE (310-320-330) STEERING COLUMN COLUMNA PLANTON LENKSÄULE	DALLA MACCHINA DE LA MAQUINA DE LA MACHINE FROM THE MACHINE AB DER MASCHINE	_____	10 A 01	Vncd 9/1997
				★N.		

Pos.	Code	Q.ty	Description	Notes
59056912	59056912	0	COLUMN	
59056935	59056935	0	LEVER	

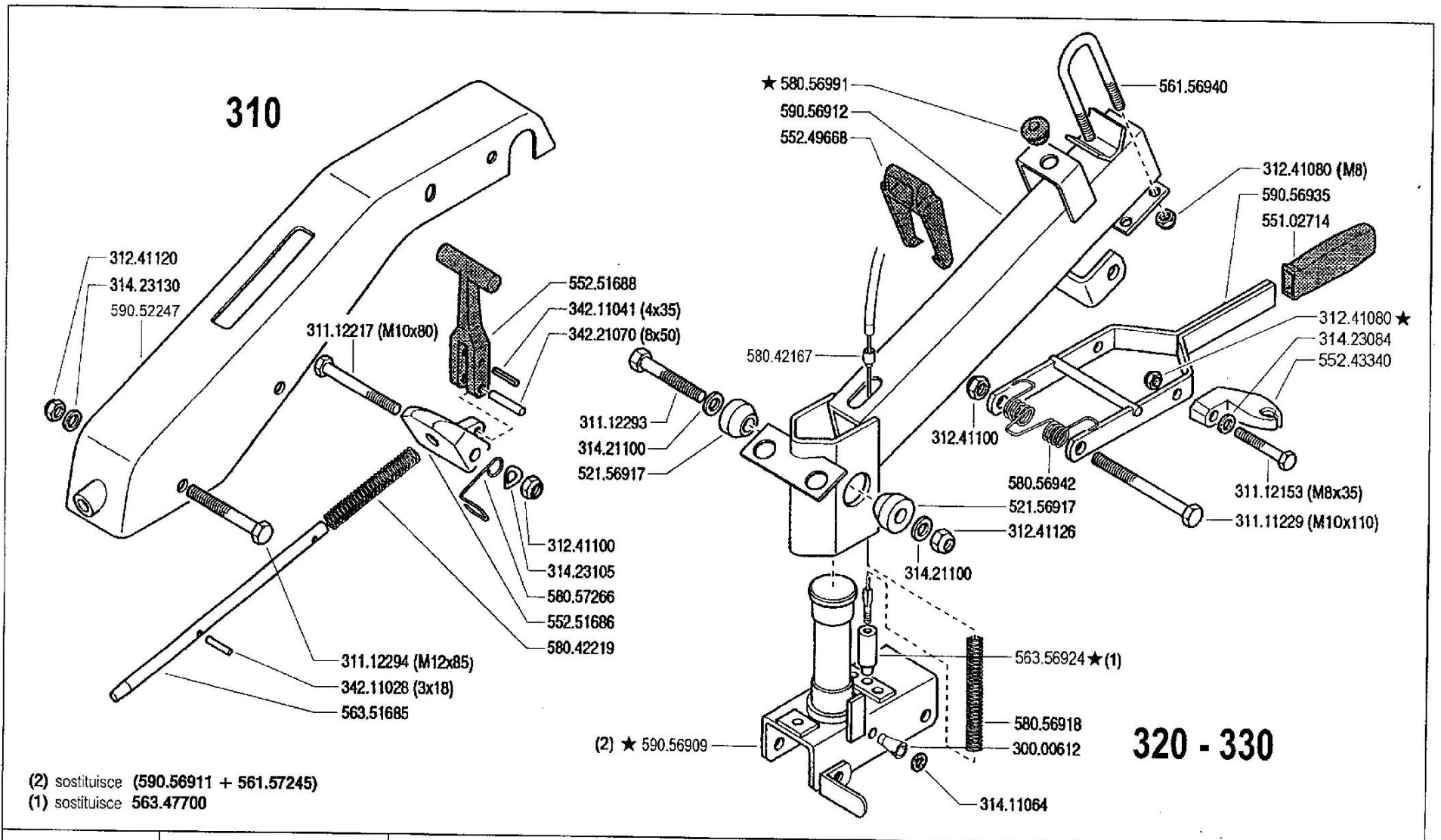

(2) sostituisce (590.56911 + 561.57245)
(1) sostituisce 563.47700

	300 serie 95	PIANTONE (310-320-330) STEERING COLUMN COLUMNNA PLANTON LENKSÄULE	DALLA MACCHINA DE LA MAQUINA DE LA MACHINE FROM THE MACHINE AB DER MASCHINE	AGGIORNAMENTO REVISION MISE A JOUR APLAZAMIENTO ANPASSUNG	10 A	Rev. 2
			★ N	3/2001		

REV. 2

Pos.	Code	Q.ty	Description	Notes
30000612	30000612	0	BLOCK	
31111229	31111229	0	SCREW TE M10X110 UNI 5737 8G	
31112153	31112153	0	SCREW TE M8X35 UNI 5739 8G	
31112154	31112154	0	SCREW TE M8X40 UNI 5739 8G	
31112217	31112217	0	SCREW TE M10X80 UNI 5737	
31112293	31112293	0	SCREW TE M12X80 UNI 5737	
31112294	31112294	0	SCREW TE M12X85 UNI 5737	
31241080	31241080	0	HEXAGON SELFLOCK NUT M8	
31241100	31241100	0	SELFLOCK HEXAGON NUT M10	
31241120	31241120	0	SELFLOCK NUT M12	
31241126	31241126	0	SELFLOCK NUT M12	
31411064	31411064	0	WASHER 6,4x12,5	
31421100	31421100	0	CUP SPRING	
31423084	31423084	0	SPRING WASHER 8,4	
31423105	31423105	0	SPRING WASHER 10,5	
31423130	31423130	0	SPRING WASHER 13	
34211028	34211028	0	ROLL PIN	
34211041	34211041	0	ROLL PIN	
34221070	34221070	0	CYLINDRICAL PLUG 8X50 UNI 1707	
52156917	52156917	0	WEDGE	
55102714	55102714	0	KNOB	
55243340	55243340	0	SUPPORT	
55249668	55249668	0	PASSING	
55251686	55251686	0	LEVER BEARING	
55251688	55251688	0	LEVER	
56156940	56156940	0	U BOLT	
56351685	56351685	0	ROD	
56356924	56356924	0	FERRULE	
58042167	58042167	0	SHEATH TERMINAL	
58042219	58042219	0	SPRING	
58056918	58056918	0	SPRING	
58056942	58056942	0	SPRING	
58056991	58056991	0	CABLE GLAND	
58057266	58057266	0	HOLDER	

SERIAL

STEERING COLUMN (310-320-330)

CODE REV

10A_2_12281

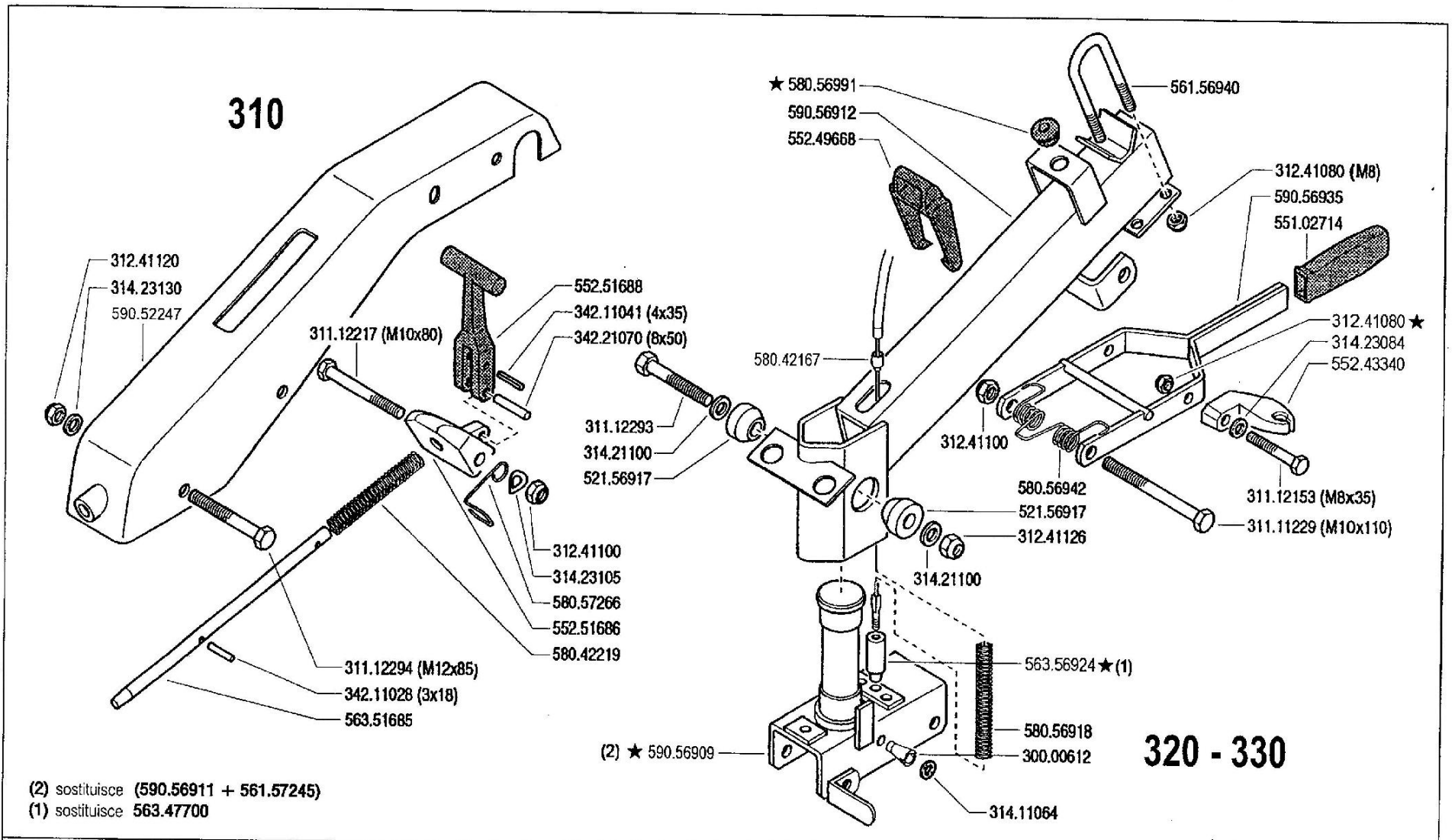

(2) sostituisce (590.56911 + 561.57245)
(1) sostituisce 563.47700

FERRARI	300 serie 95	STEERING COLUMN COLUMNNA	PIANTONE (310-320-330)	PLANTON LENKSÄULE	DALLA MACCHINA DE LA MAQUINA DE LA MACHINE FROM THE MACHINE AB DER MASCHINE	AGGIORNAMENTO	10	A	Rev. 2
						REVISION			
						MISE A JOUR			
						APLAZAMIENTO			
						ANPASSUNG			
					★N		3/2001		

Pos.	Code	Q.ty	Description	Notes
59052239	59052239	0	COMPLETE BUMPERS	
59052247	59052247	0	HANDLE BAR COLUMN	
59056909	59056909	0	SUPPORT	
59056912	59056912	0	COLUMN	
59056935	59056935	0	LEVER	
59057556	59057556	0	SUPPORT	

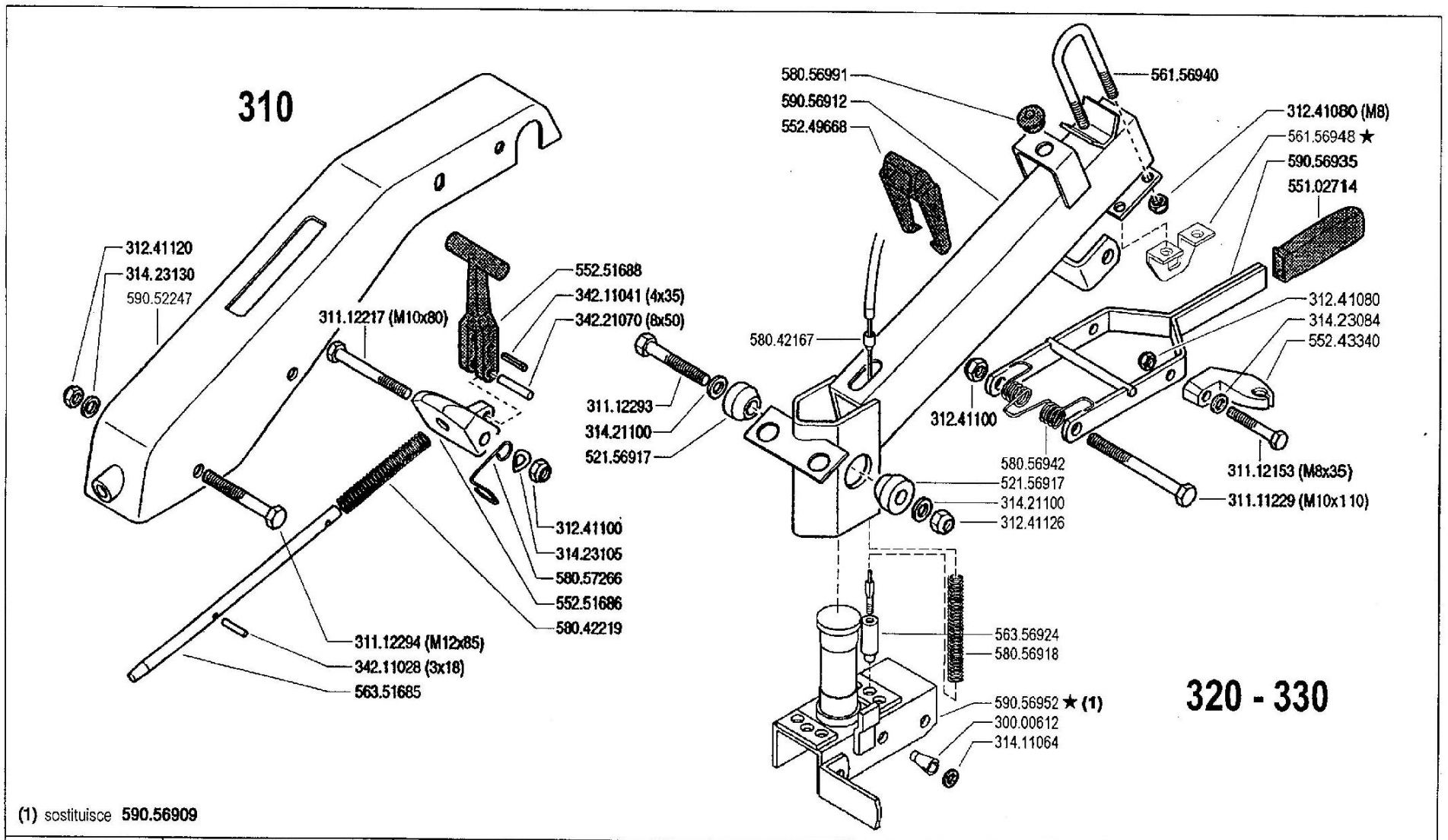

(1) sostituisce 590.56909

	300 serie 95	PIANTONE (310-320-330) STEERING COLUMN COLUMNNA PLANTON LENKSÄULE	DALLA MACCHINA DE LA MAQUINA DE LA MACHINE FROM THE MACHINE AB DER MASCHINE	AGGIORNAMENTO REVISION MISE A JOUR APLAZAMIENTO ANPASSUNG	10 A	Rev. 3
			★N	3/2003		

Pos.	Code	Q.ty	Description	Notes
30000612	30000612	0	BLOCK	
31111229	31111229	0	SCREW TE M10X110 UNI 5737 8G	
31112153	31112153	0	SCREW TE M8X35 UNI 5739 8G	
31112217	31112217	0	SCREW TE M10X80 UNI 5737	
31112293	31112293	0	SCREW TE M12X80 UNI 5737	
31112294	31112294	0	SCREW TE M12X85 UNI 5737	
31241080	31241080	0	HEXAGON SELFLOCK NUT M8	
31241100	31241100	0	SELFLOCK HEXAGON NUT M10	
31241120	31241120	0	SELFLOCK NUT M12	
31241126	31241126	0	SELFLOCK NUT M12	
31411064	31411064	0	WASHER 6,4x12,5	
31421100	31421100	0	CUP SPRING	
31423084	31423084	0	SPRING WASHER 8,4	
31423105	31423105	0	SPRING WASHER 10,5	
31423130	31423130	0	SPRING WASHER 13	
34211028	34211028	0	ROLL PIN	
34211041	34211041	0	ROLL PIN	
34221070	34221070	0	CYLINDRICAL PLUG 8X50 UNI 1707	
52156917	52156917	0	WEDGE	
55102714	55102714	0	KNOB	
55243340	55243340	0	SUPPORT	
55249668	55249668	0	PASSING	
55251686	55251686	0	LEVER BEARING	
55251688	55251688	0	LEVER	
56156940	56156940	0	U BOLT	
56156948	56156948	0	STOP	
56351685	56351685	0	ROD	
56356924	56356924	0	FERRULE	
58042167	58042167	0	SHEATH TERMINAL	
58042219	58042219	0	SPRING	
58056918	58056918	0	SPRING	
58056942	58056942	0	SPRING	
58056991	58056991	0	CABLE GLAND	
58057266	58057266	0	HOLDER	

SERIAL

STEERING COLUMN (310-320-330)

CODE REV

10A_3_12322

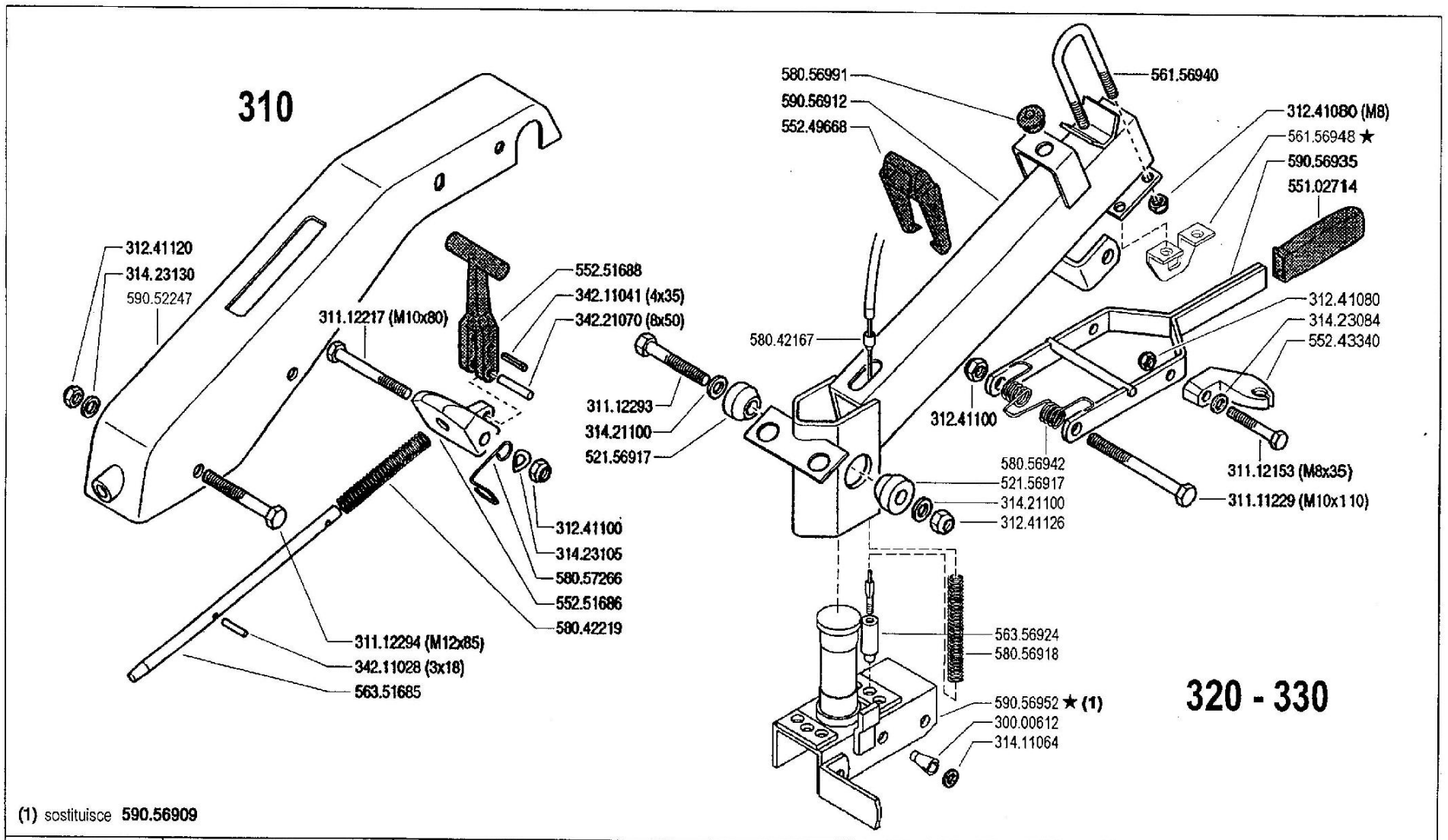

(1) sostituisce 590.56909

	300 serie 95	PIANTONE (310-320-330) STEERING COLUMN COLUMNNA PLANTON LENKSÄULE	DALLA MACCHINA DE LA MAQUINA DE LA MACHINE FROM THE MACHINE AB DER MASCHINE	AGGIORNAMENTO REVISION MISE A JOUR APLAZAMIENTO ANPASSUNG	10 A	Rev. 3
			★N	3/2003		

Pos.	Code	Q.ty	Description	Notes
59052247	59052247	0	HANDLE BAR COLUMN	
59056912	59056912	0	COLUMN	
59056935	59056935	0	LEVER	
59056952	59056952	0	SUPPORT	

320 - 330

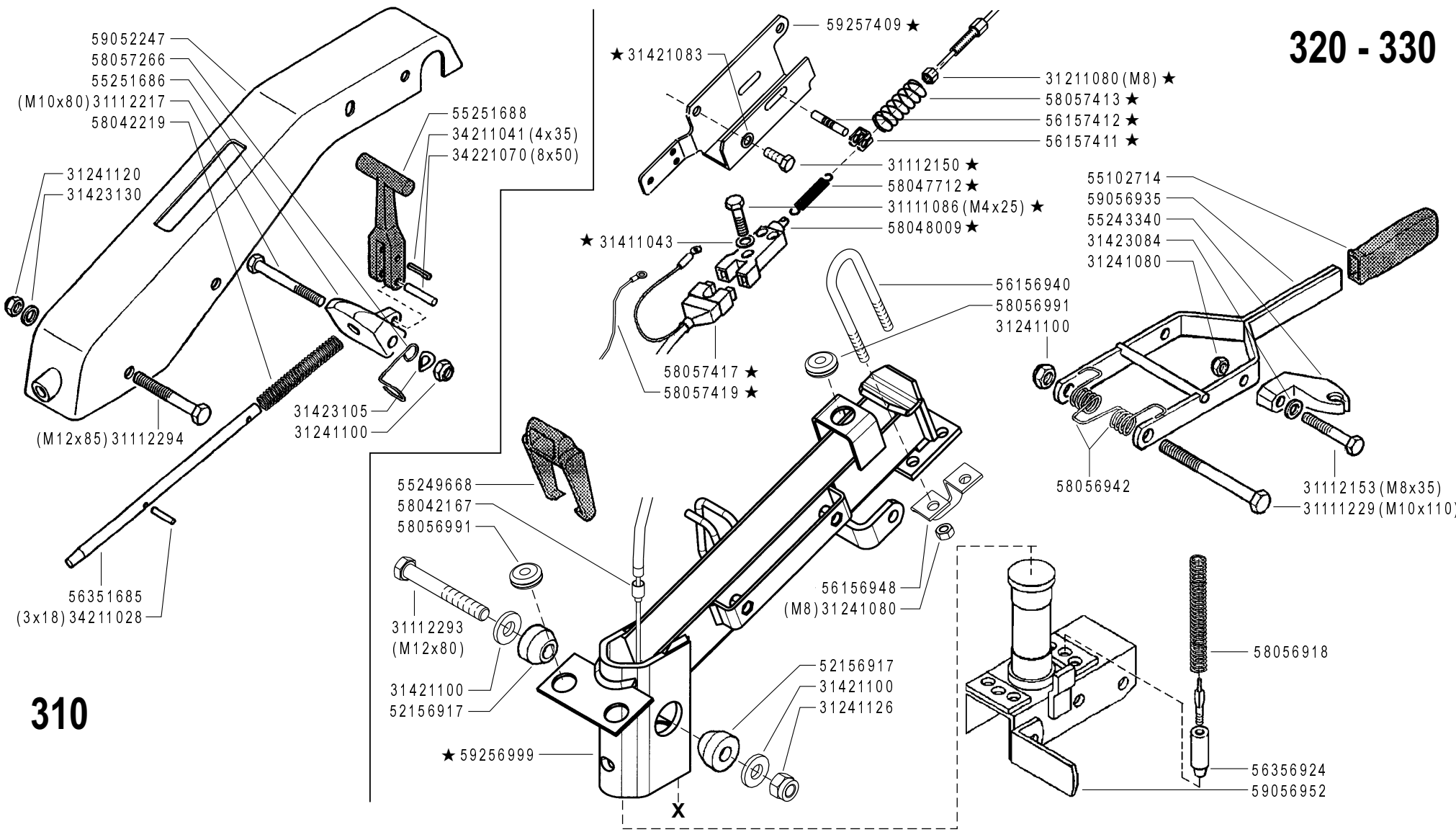

	<h2>300 serie 95</h2>	PIANTONE (310-320-330) STEERING COLUMN COLUMNNA	PLANTON LENKSÄULE	DALLA MACCHINA DE LA MAQUINA DE LA MACHINE FROM THE MACHINE AB DER MASCHINE ★N.	AGGIORNAMENTO	<h1>10 A 4</h1>	Rev. 01/2008
					REVISION		

ZENNE

Pos.	Code	Q.ty	Description	Notes
31111086	31111086	1	SCREW TE M4X25 UNI 5739 8G	
31111229	31111229	1	SCREW TE M10X110 UNI 5737 8G	
31112150	31112150	1	SCREW TE M8X20 UNI 5739 8G	
31112153	31112153	1	SCREW TE M8X35 UNI 5739 8G	
31112217	31112217	1	SCREW TE M10X80 UNI 5737	
31112293	31112293	1	SCREW TE M12X80 UNI 5737	
31112294	31112294	1	SCREW TE M12X85 UNI 5737	
31211080	31211080	1	NUT M8	
31241080	31241080	1	HEXAGON SELFLOCK NUT M8	
31241100	31241100	1	SELFLOCK HEXAGON NUT M10	
31241120	31241120	1	SELFLOCK NUT M12	
31241126	31241126	1	SELFLOCK NUT M12	
31411043	31411043	1	WASHER 4,3X9	
31421083	31421083	1	WASHER	
31421100	31421100	1	CUP SPRING	
31423084	31423084	1	SPRING WASHER 8,4	
31423105	31423105	1	SPRING WASHER 10,5	
31423130	31423130	1	SPRING WASHER 13	
34211028	34211028	1	ROLL PIN	
34211041	34211041	1	ROLL PIN	
34221070	34221070	1	CYLINDRICAL PLUG 8X50 UNI 1707	
52156917	52156917	1	WEDGE	
55102714	55102714	1	KNOB	
55243340	55243340	1	SUPPORT	
55249668	55249668	1	PASSING	
55251686	55251686	1	LEVER BEARING	
55251688	55251688	1	LEVER	
56156940	56156940	1	U BOLT	
56156948	56156948	1	STOP	
56157411	56157411	1	FORK	
56157412	56157412	1	PIN	
56351685	56351685	1	ROD	
56356924	56356924	1	FERRULE	
58042167	58042167	1	SHEATH TERMINAL	

SERIAL

STEERING COLUMN (310-320-330)

CODE REV

10A_4_63871

320 - 330

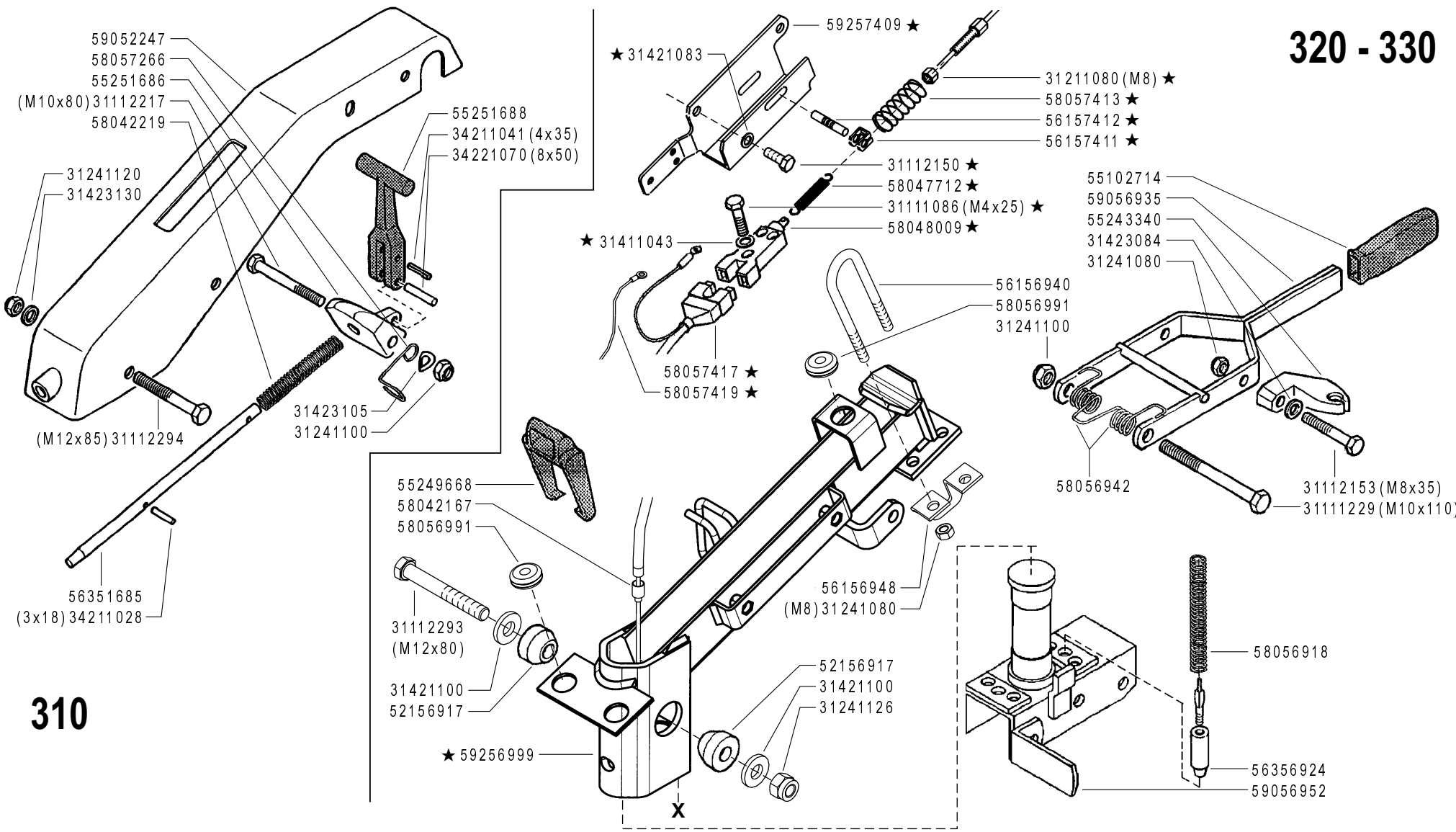

310



300 serie 95

PIANTONE (310-320-330)

STEERING COLUMN
COLUMNNA

PLANTON
LENKSÄULE

DALLA MACCHINA
DE LA MAQUINA
DE LA MACHINE
FROM THE MACHINE
AB DER MASCHINE
★N.

AGGIORNAMENTO
REVISION
MISE A JOUR
APLAZAMIENTO
ANPASSUNG

Rev. **10 A 4**
01/2008

ZENNE

Pos.	Code	Q.ty	Description	Notes
58042219	58042219	1	SPRING	
58047712	58047712	1	SPRING	
58048009	58048009	1	SWITCH	
58056918	58056918	1	SPRING	
58056942	58056942	1	SPRING	
58056991	58056991	1	CABLE GLAND	
58057266	58057266	1	HOLDER	
58057413	58057413	1	RETAINING SPRING	
58057417	58057417	1	WIRING	
58057419	58057419	1	WIRING	
59052247	59052247	1	HANDLE BAR COLUMN	
59056912	59056912	1	COLUMN	
59056935	59056935	1	LEVER	
59056952	59056952	1	SUPPORT	
59256999	59256999	1	COLUMN	
59257409	59257409	1	SUPPORT	

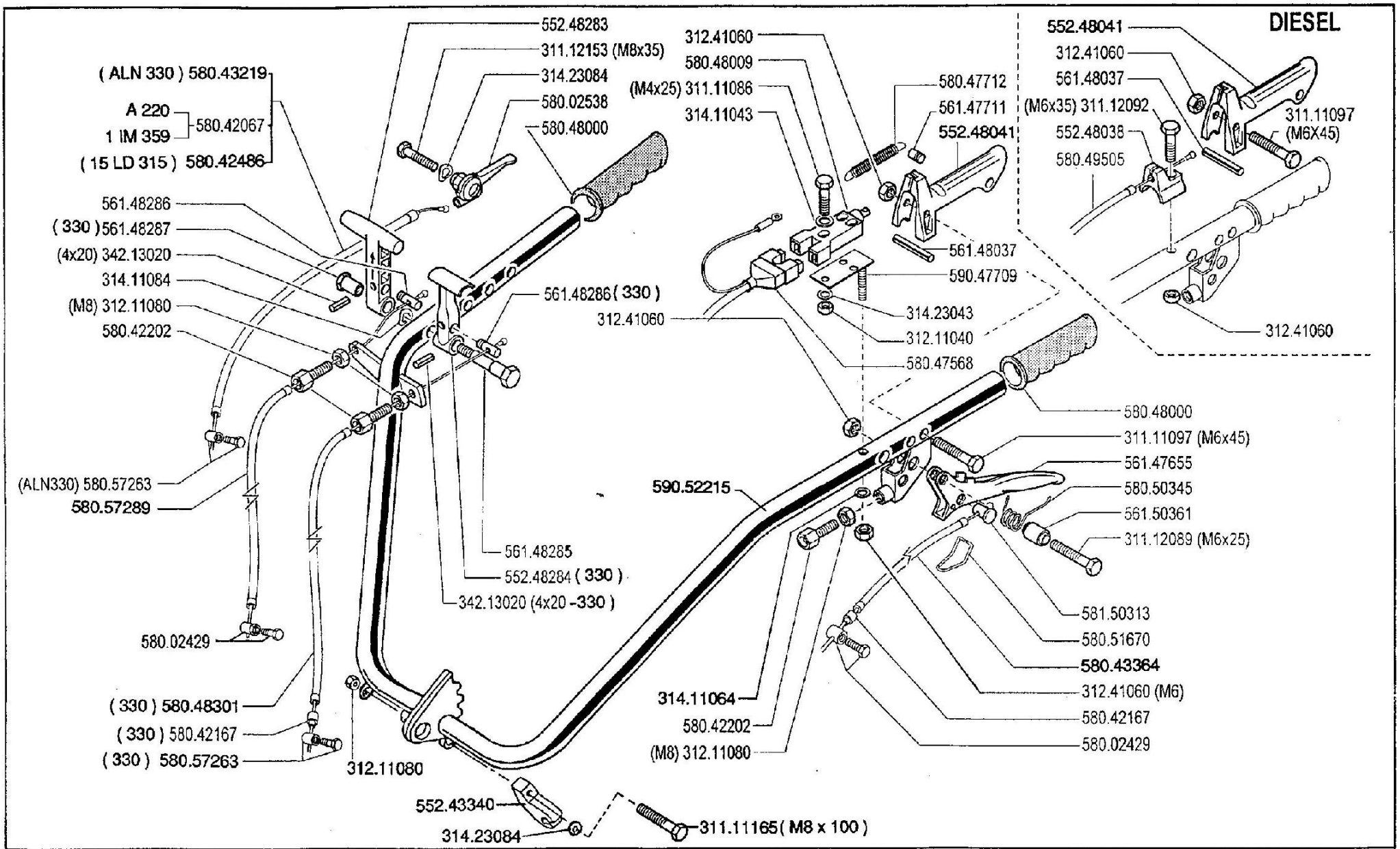

FERRARI

300 serie **95**

MANILLAR
MANCHERON

MANUBRIO (320 - 330)

HANDLEBAR
LENKER

DALLA MACCHINA
DE LA MAQUINA
DE LA MACHINE
FROM THE MACHINE
AB DER MASCHINE

N.

12.00

01.06.1995

Pos.	Code	Q.ty	Description	Notes
31111086	31111086	0	SCREW TE M4X25 UNI 5739 8G	
31111097	31111097	0	SCREW TE M6X45 UNI 5737 8G	
31111165	31111165	0	SCREW TE M8X100 UNI 5737 8G	
31112089	31112089	0	SCREW TE M6X25 UNI 5739 8G	
31112092	31112092	0	SCREW TE M6X35 UNI 5739 8G	
31112153	31112153	0	SCREW TE M8X35 UNI 5739 8G	
31211040	31211040	0	NUT M4	
31211080	31211080	0	NUT M8	
31241060	31241060	0	HEXAGON SELFLOCK NUT M6	
31411043	31411043	0	WASHER 4,3X9	
31411064	31411064	0	WASHER 6,4x12,5	
31411084	31411084	0	WASHER 8,4x17	
31423043	31423043	0	SPRING WASHER 4,3	
31423084	31423084	0	SPRING WASHER 8,4	
34213020	34213020	0	ROLL PIN	
55243340	55243340	0	SUPPORT	
55248038	55248038	0	STOP	
55248041	55248041	0	LEVER	
55248283	55248283	0	COMMAND LEVER	
55248284	55248284	0	LEVER	
56147655	56147655	0	CLUTCH LEVER	
56147711	56147711	0	PIN	
56148037	56148037	0	LEVER STOP	
56148285	56148285	0	PIN	
56148286	56148286	0	PIN	
56148287	56148287	0	STUD BOLT	
56150361	56150361	0	SPACER	
58002429	58002429	0	CLAMPING SCREW	
58002538	58002538	0	COMMAND LEVER	
58042067	58042067	0	LINE AND SHEATH	
58042167	58042167	0	SHEATH TERMINAL	
58042202	58042202	0	ADJUSTING SCREW	
58042486	58042486	0	LINE AND SHEATH	
58043219	58043219	0	LINE AND SHEATH	

SERIAL

012_00 - HANDLEBAR (320-330)

CODE REV

012_0_11498

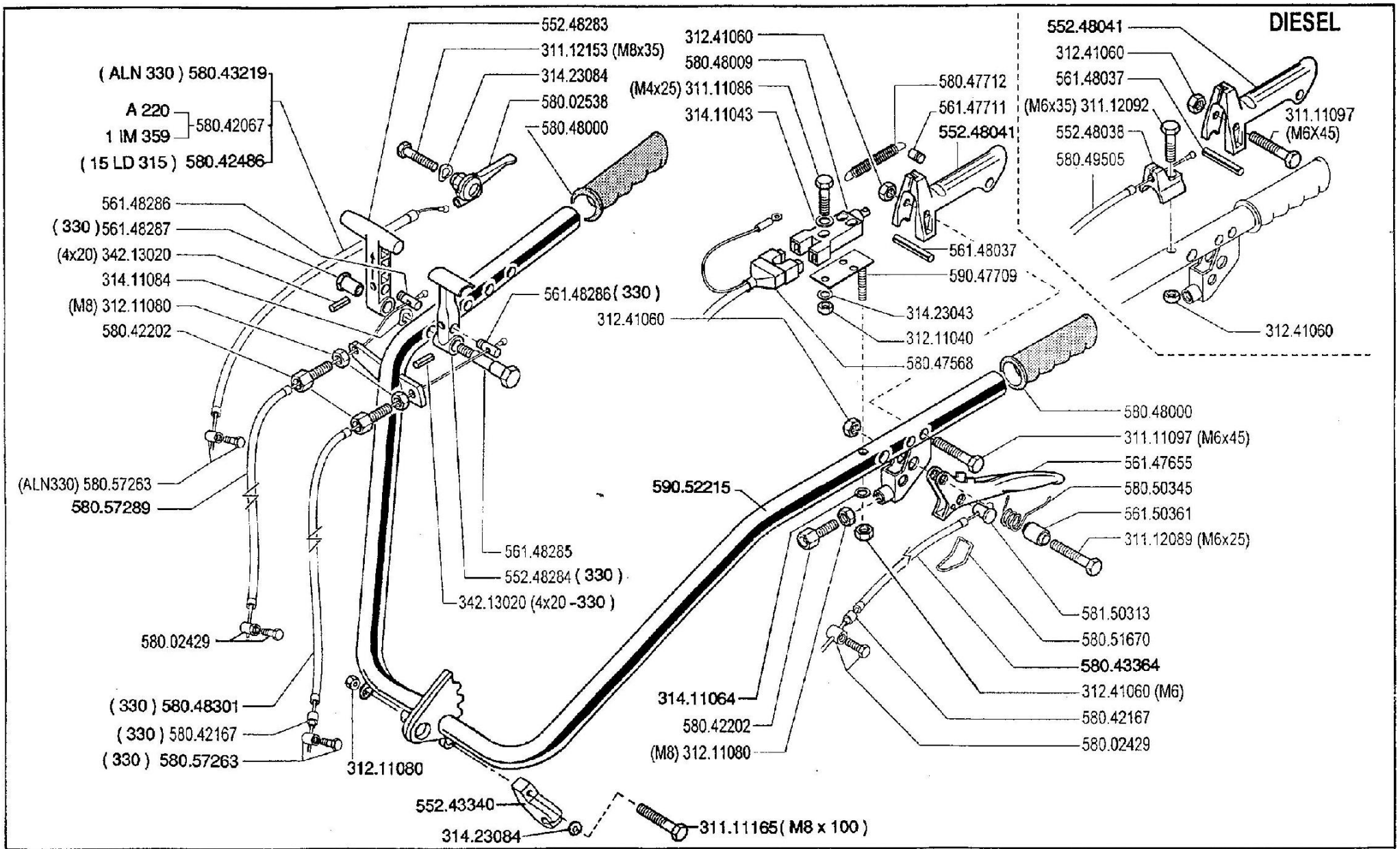

FERRARI

300 serie **95**

MANILLAR
MANCHERON

MANUBRIO (320 - 330)

HANDLEBAR
LENKER

DALLA MACCHINA
DE LA MAQUINA
DE LA MACHINE
FROM THE MACHINE
AB DER MASCHINE

N.

12.00

01.06.1995

Pos.	Code	Q.ty	Description	Notes
58043364	58043364	0	LINE AND SHEATH	
58047568	58047568	0	WIRING	
58047712	58047712	0	SPRING	
58048000	58048000	0	KNOB	
58048009	58048009	0	SWITCH	
58048301	58048301	0	LINE AND SHEATH	
58049505	58049505	0	LINE AND SHEATH	
58050345	58050345	0	SPRING	
58051670	58051670	0	CLEVIS	
58057263	58057263	0	CLAMPING SCREW	
58057289	58057289	0	LINE AND SHEATH	
58150313	58150313	0	CABLE CLAMP	
59047709	59047709	0	SWITCH SUPPORT	
59052215	59052215	0	COMPLETE HANDLE BAR	

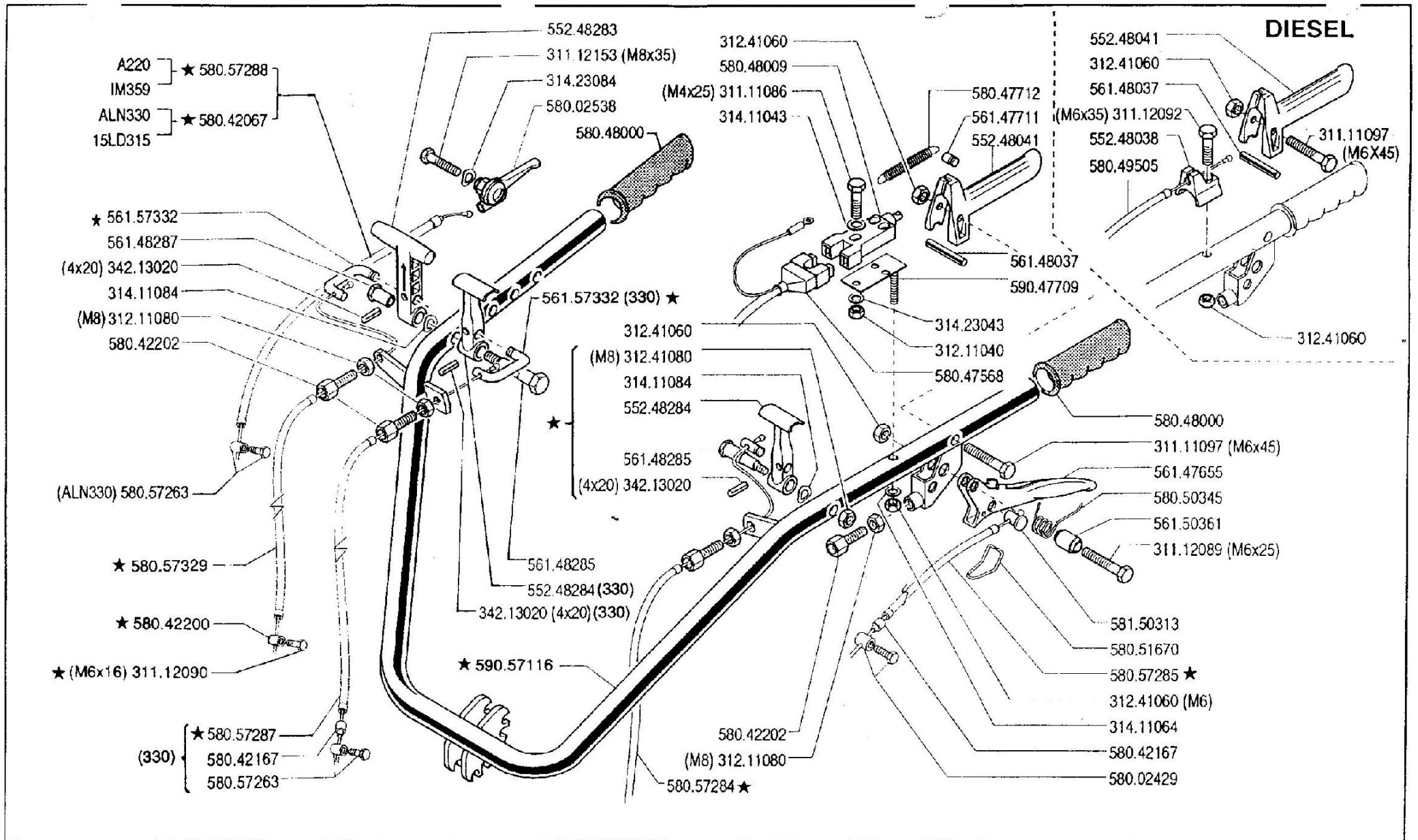

FERRARI

300 serie **95**

MANUBRIO (320-330)

MANILLAR

HANDLEBAR

MANCHERON

LENKER

DALLA MACCHINA
DE LA MAQUINA
DE LA MACHINE
FROM THE MACHINE
AB DER MASCHINE

★ N.

202978 (330)

112717 (320)

12.01

11.1996

Pos.	Code	Q.ty	Description	Notes
31111086	31111086	0	SCREW TE M4X25 UNI 5739 8G	
31111097	31111097	0	SCREW TE M6X45 UNI 5737 8G	
31112089	31112089	0	SCREW TE M6X25 UNI 5739 8G	
31112090	31112090	0	SCREW TE M6X16 UNI 5739 8G	
31112092	31112092	0	SCREW TE M6X35 UNI 5739 8G	
31112153	31112153	0	SCREW TE M8X35 UNI 5739 8G	
31211040	31211040	0	NUT M4	
31211080	31211080	0	NUT M8	
31241060	31241060	0	HEXAGON SELFLOCK NUT M6	
31241080	31241080	0	HEXAGON SELFLOCK NUT M8	
31411043	31411043	0	WASHER 4,3X9	
31411064	31411064	0	WASHER 6,4x12,5	
31411084	31411084	0	WASHER 8,4x17	
31423043	31423043	0	SPRING WASHER 4,3	
31423084	31423084	0	SPRING WASHER 8,4	
34213020	34213020	0	ROLL PIN	
55248038	55248038	0	STOP	
55248041	55248041	0	LEVER	
55248283	55248283	0	COMMAND LEVER	
55248284	55248284	0	LEVER	
56147655	56147655	0	CLUTCH LEVER	
56147711	56147711	0	PIN	
56148037	56148037	0	LEVER STOP	
56148285	56148285	0	PIN	
56148287	56148287	0	STUD BOLT	
56150361	56150361	0	SPACER	
56157332	56157332	0	U BOLT	
58002429	58002429	0	CLAMPING SCREW	
58002538	58002538	0	COMMAND LEVER	
58042067	58042067	0	LINE AND SHEATH	
58042167	58042167	0	SHEATH TERMINAL	
58042200	58042200	0	CLAMPING SCREW	
58042202	58042202	0	ADJUSTING SCREW	
58047568	58047568	0	WIRING	

SERIAL

012_01 - HANDLEBAR (320-330)

Version: MC 320, MC 330

CODE REV

012_1_11547

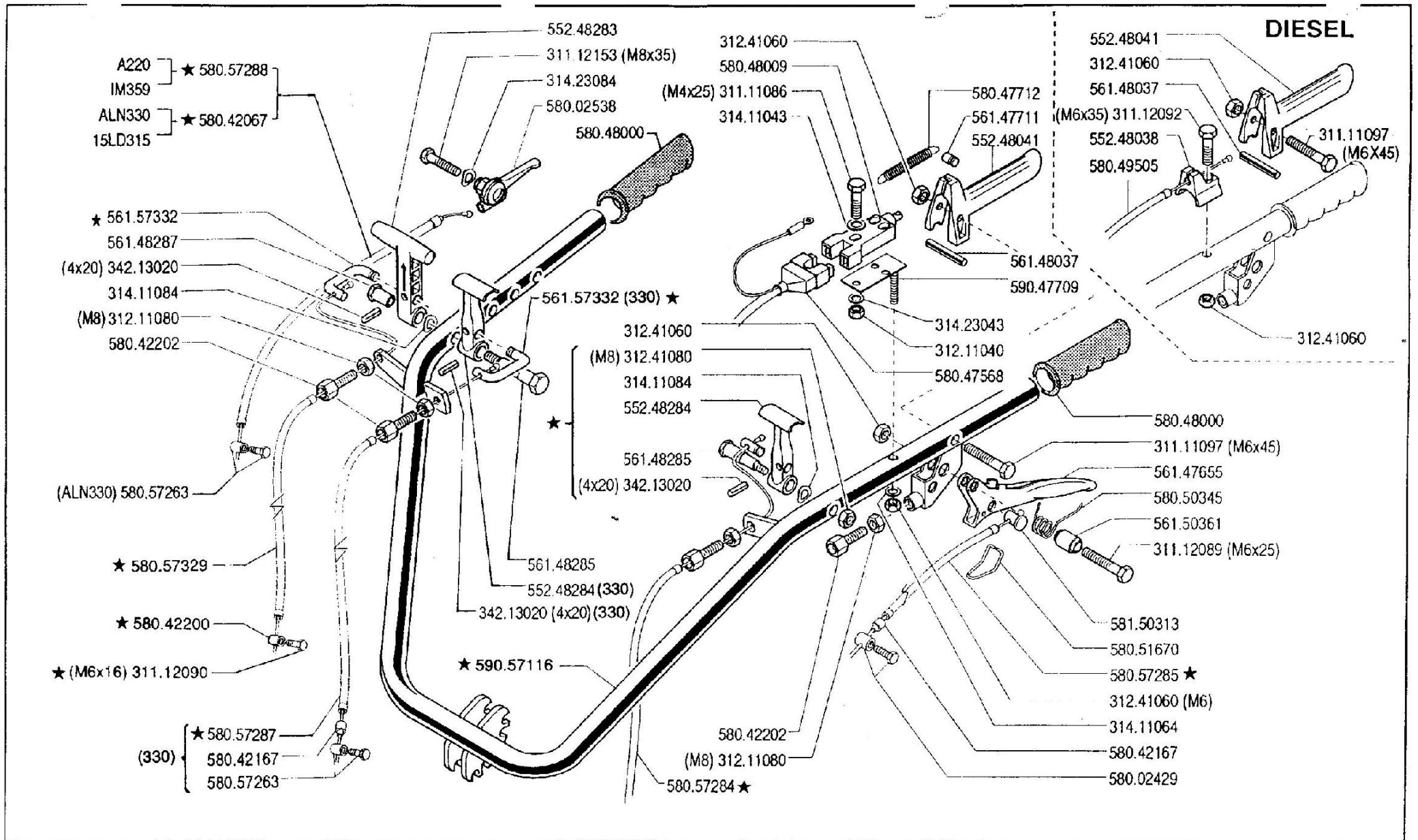

FERRARI

300 serie **95**

MANUBRIO (320-330)

MANILLAR

HANDLEBAR

MANCHERON

LENKER

DALLA MACCHINA
DE LA MAQUINA
DE LA MACHINE
FROM THE MACHINE
AB DER MASCHINE

★ N.

202978 (330)

112717 (320)

12.01

11.1996

Pos.	Code	Q.ty	Description	Notes
58047712	58047712	0	SPRING	
58048000	58048000	0	KNOB	
58048009	58048009	0	SWITCH	
58049505	58049505	0	LINE AND SHEATH	
58050345	58050345	0	SPRING	
58051670	58051670	0	CLEVIS	
58057263	58057263	0	CLAMPING SCREW	
58057284	58057284	0	LINE AND SHEATH	
58057285	58057285	0	LINE AND SHEATH	
58057287	58057287	0	LINE AND SHEATH	
58057288	58057288	0	LINE AND SHEATH	
58057329	58057329	0	LINE AND SHEATH	
58150313	58150313	0	CABLE CLAMP	
59047709	59047709	0	SWITCH SUPPORT	
59057116	59057116	0	COMPLETE HANDLE BAR	

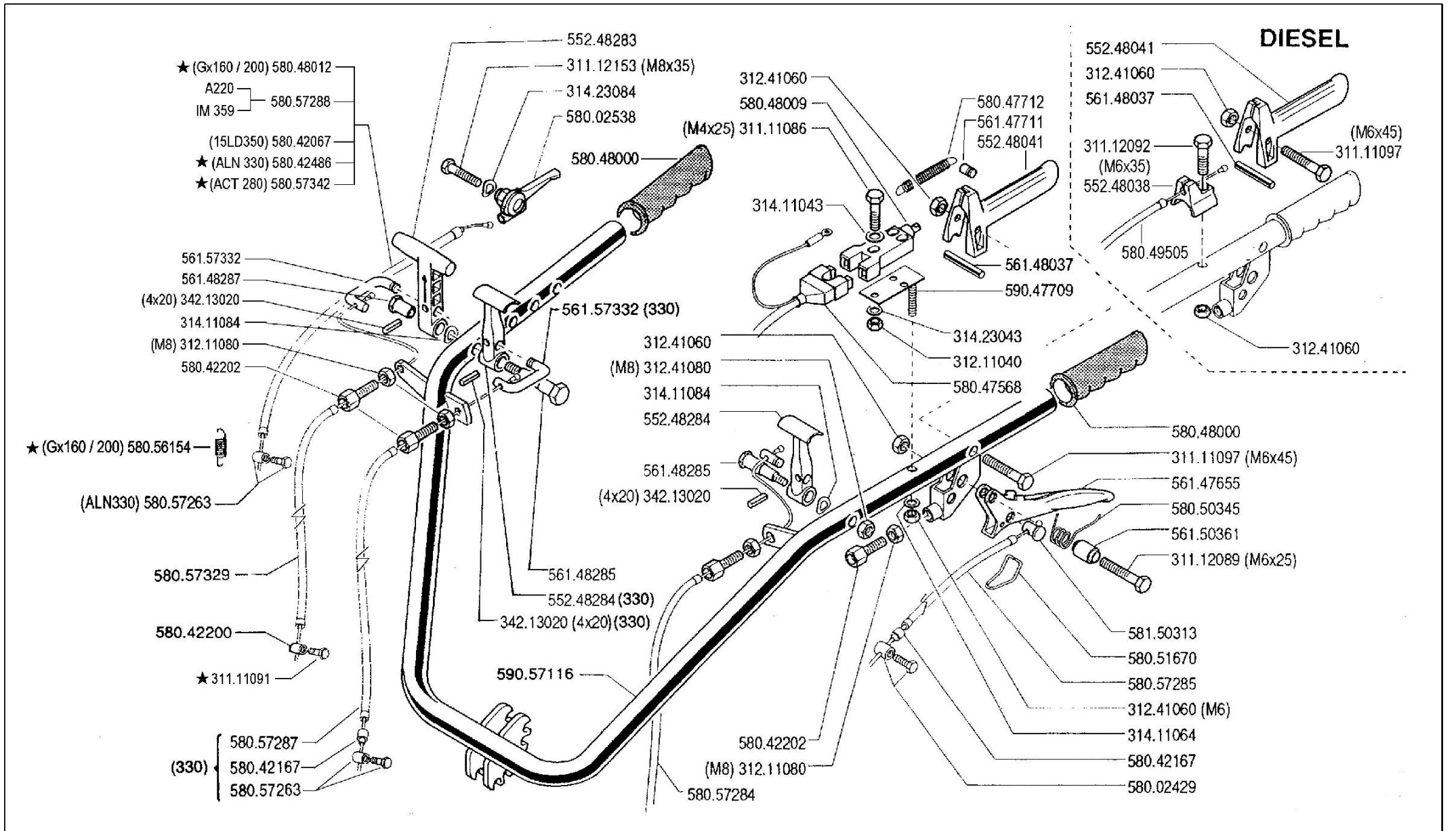

FERRARI

300 serie **95**

HANDLEBAR
 MANILLAR

MANUBRIO (320-330)

MANCHERON
 LENKER

DALLA MACCHINA
 DE LA MAQUINA
 DE LA MACHINE
 FROM THE MACHINE
 AB DER MASCHINE

AGGIORNAMENTO

REVISION

MISE A JOUR

APLAZAMIENTO

ANPASSUNG

12 02

1/2000

★N.

Pos.	Code	Q.ty	Description	Notes
31111086	31111086	0	SCREW TE M4X25 UNI 5739 8G	
31111091	31111091	0	SCREW E M6X14 UNI 5739 8G	
31111097	31111097	0	SCREW TE M6X45 UNI 5737 8G	
31112089	31112089	0	SCREW TE M6X25 UNI 5739 8G	
31112092	31112092	0	SCREW TE M6X35 UNI 5739 8G	
31112153	31112153	0	SCREW TE M8X35 UNI 5739 8G	
31211040	31211040	0	NUT M4	
31211080	31211080	0	NUT M8	
31241060	31241060	0	HEXAGON SELFLOCK NUT M6	
31241080	31241080	0	HEXAGON SELFLOCK NUT M8	
31411043	31411043	0	WASHER 4,3X9	
31411064	31411064	0	WASHER 6,4x12,5	
31411084	31411084	0	WASHER 8,4x17	
31423043	31423043	0	SPRING WASHER 4,3	
31423084	31423084	0	SPRING WASHER 8,4	
34213020	34213020	0	ROLL PIN	
55248038	55248038	0	STOP	
55248041	55248041	0	LEVER	
55248283	55248283	0	COMMAND LEVER	
55248284	55248284	0	LEVER	
56147655	56147655	0	CLUTCH LEVER	
56147711	56147711	0	PIN	
56148037	56148037	0	LEVER STOP	
56148285	56148285	0	PIN	
56148287	56148287	0	STUD BOLT	
56150361	56150361	0	SPACER	
56157332	56157332	0	U BOLT	
58002429	58002429	0	CLAMPING SCREW	
58002538	58002538	0	COMMAND LEVER	
58042067	58042067	0	LINE AND SHEATH	
58042167	58042167	0	SHEATH TERMINAL	
58042200	58042200	0	CLAMPING SCREW	
58042202	58042202	0	ADJUSTING SCREW	
58042486	58042486	0	LINE AND SHEATH	

SERIAL

012_02 - HANDLEBAR (320-330)

CODE REV

012_2_11597

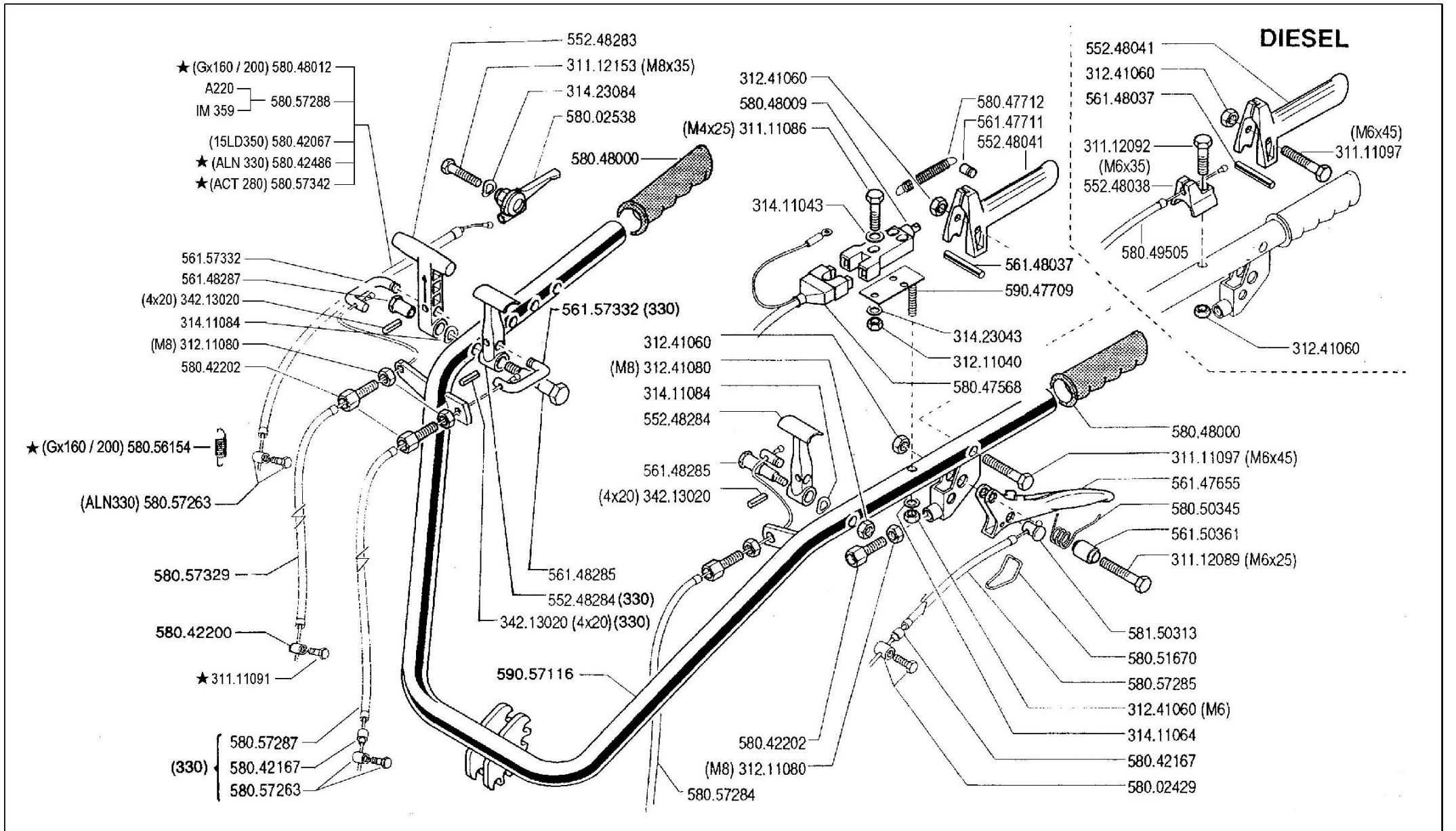

FERRARI

300 serie **95**

HANDLEBAR
 MANILLAR

MANUBRIO (320-330)

MANCHERON
 LENKER

DALLA MACCHINA
 DE LA MAQUINA
 DE LA MACHINE
 FROM THE MACHINE
 AB DER MASCHINE

AGGIORNAMENTO

REVISION

MISE A JOUR

APLAZAMIENTO

ANPASSUNG

12 **02**

1/2000

★N.

Pos.	Code	Q.ty	Description	Notes
58047568	58047568	0	WIRING	
58047712	58047712	0	SPRING	
58048000	58048000	0	KNOB	
58048009	58048009	0	SWITCH	
58048012	58048012	0	LINE AND SHEATH	
58049505	58049505	0	LINE AND SHEATH	
58050345	58050345	0	SPRING	
58051670	58051670	0	CLEVIS	
58056154	58056154	0	RESTORING SPRING	Utilizzato con motore GX200
58057263	58057263	0	CLAMPING SCREW	
58057284	58057284	0	LINE AND SHEATH	
58057285	58057285	0	LINE AND SHEATH	
58057287	58057287	0	LINE AND SHEATH	
58057288	58057288	0	LINE AND SHEATH	
58057329	58057329	0	LINE AND SHEATH	
58057342	58057342	0	LINE AND SHEATH	
58150313	58150313	0	CABLE CLAMP	
59047709	59047709	0	SWITCH SUPPORT	
59057116	59057116	0	COMPLETE HANDLE BAR	

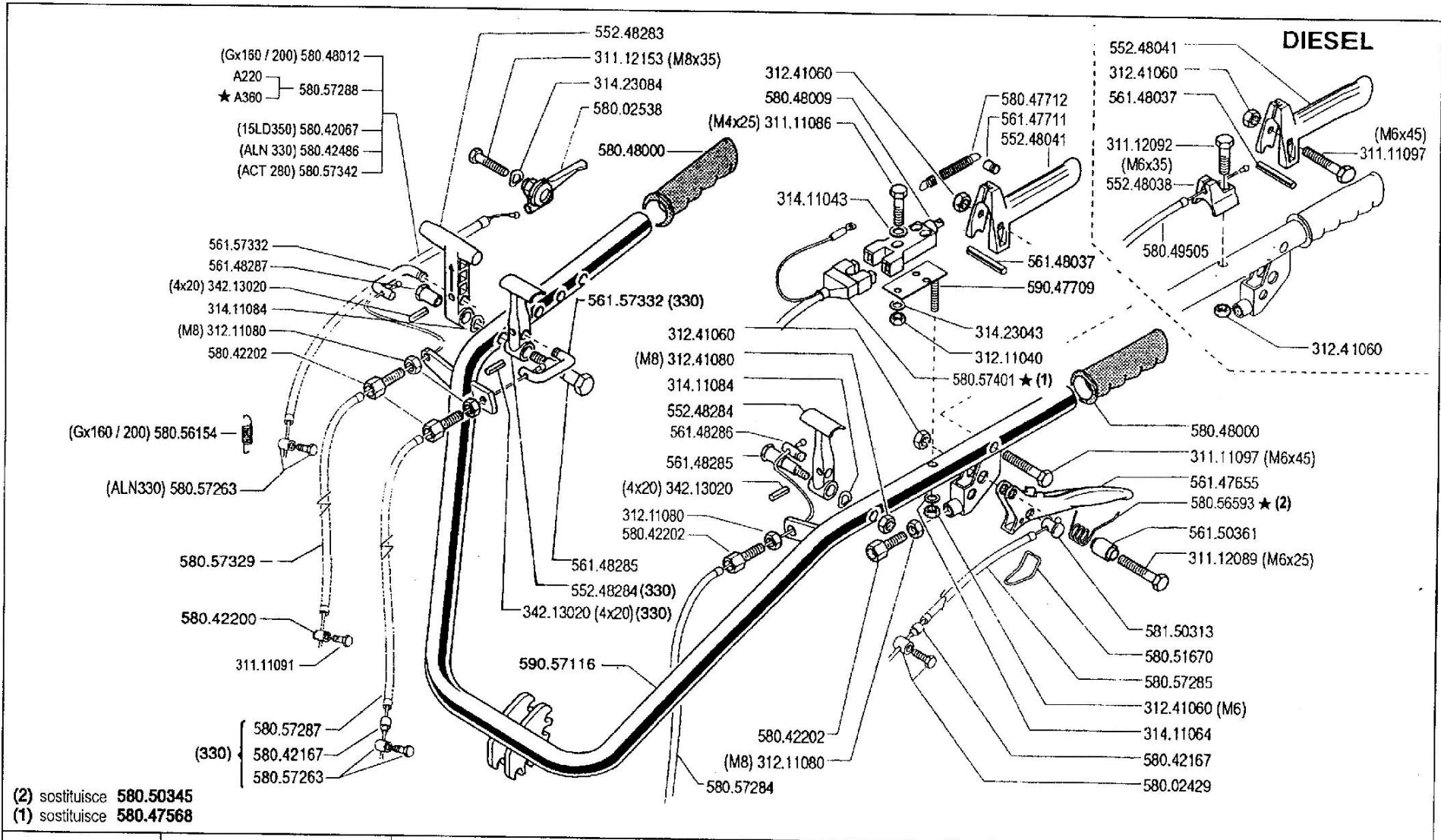

(2) sostituisce 580.50345
 (1) sostituisce 580.47568

FERRARI	300 serie 95	MANUBRIO (320-330)		DALLA MACCHINA DE LA MAQUINA DE LA MACHINE FROM THE MACHINE AB DER MASCHINE	AGGIORNAMENTO	12	Rev. 3
		HANDLEBAR MANILLAR	MANCHERON LENKER		REVISION		
					MISE A JOUR		
					APLAZAMIENTO		
					ANPASSUNG	11/2002	

★N.

ZEMME

Pos.	Code	Q.ty	Description	Notes
31111086	31111086	0	SCREW TE M4X25 UNI 5739 8G	
31111091	31111091	0	SCREW E M6X14 UNI 5739 8G	
31111097	31111097	0	SCREW TE M6X45 UNI 5737 8G	
31112089	31112089	0	SCREW TE M6X25 UNI 5739 8G	
31112092	31112092	0	SCREW TE M6X35 UNI 5739 8G	
31112153	31112153	0	SCREW TE M8X35 UNI 5739 8G	
31211040	31211040	0	NUT M4	
31211080	31211080	0	NUT M8	
31241060	31241060	0	HEXAGON SELFLOCK NUT M6	
31241080	31241080	0	HEXAGON SELFLOCK NUT M8	
31411043	31411043	0	WASHER 4,3X9	
31411064	31411064	0	WASHER 6,4x12,5	
31411084	31411084	0	WASHER 8,4x17	
31423043	31423043	0	SPRING WASHER 4,3	
31423084	31423084	0	SPRING WASHER 8,4	
34213020	34213020	0	ROLL PIN	
55248038	55248038	0	STOP	
55248041	55248041	0	LEVER	
55248283	55248283	0	COMMAND LEVER	
55248284	55248284	0	LEVER	
56147655	56147655	0	CLUTCH LEVER	
56147711	56147711	0	PIN	
56148037	56148037	0	LEVER STOP	
56148285	56148285	0	PIN	
56148286	56148286	0	PIN	
56148287	56148287	0	STUD BOLT	
56150361	56150361	0	SPACER	
56157332	56157332	0	U BOLT	
58002429	58002429	0	CLAMPING SCREW	
58002538	58002538	0	COMMAND LEVER	
58042067	58042067	0	LINE AND SHEATH	
58042167	58042167	0	SHEATH TERMINAL	
58042200	58042200	0	CLAMPING SCREW	
58042202	58042202	0	ADJUSTING SCREW	

SERIAL

012_03 - HANDLEBAR (320-330)

CODE REV

012_3_11651

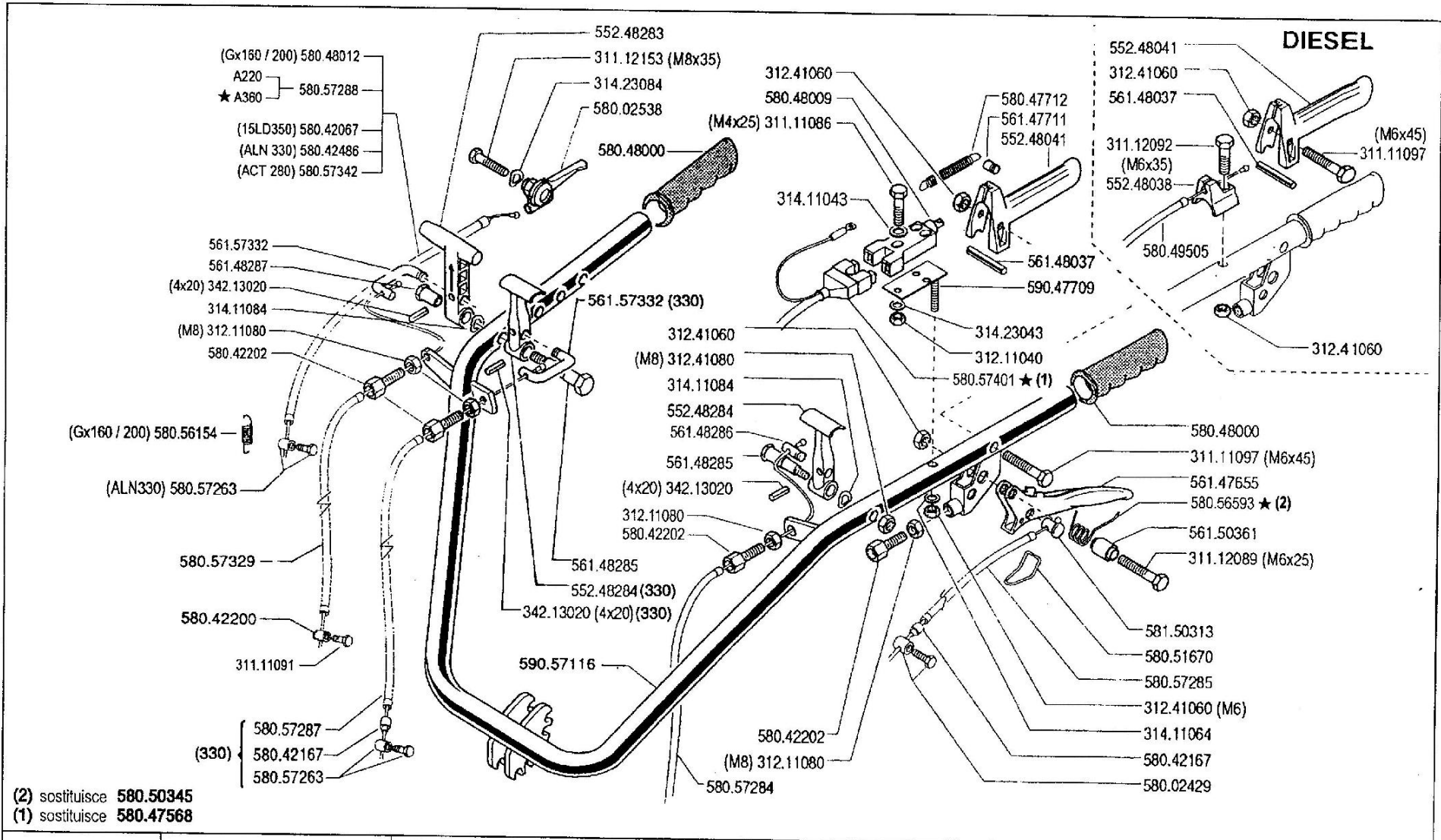

(2) sostituisce 580.50345
 (1) sostituisce 580.47568

FERRARI

300 serie **95**

MANUBRIO (320-330)

HANDLEBAR
MANILLAR

MANCHERON
LENKER

DALLA MACCHINA
 DE LA MAQUINA
 DE LA MACHINE
 FROM THE MACHINE
 AB DER MASCHINE

AGGIORNAMENTO

REVISION

MISE A JOUR

APLAZAMIENTO

ANPASSUNG

12

Rev. **3**

11/2002

★N.

ZENIT

Pos.	Code	Q.ty	Description	Notes
58042486	58042486	0	LINE AND SHEATH	
58047712	58047712	0	SPRING	
58048000	58048000	0	KNOB	
58048009	58048009	0	SWITCH	
58048012	58048012	0	LINE AND SHEATH	
58049505	58049505	0	LINE AND SHEATH	
58051670	58051670	0	CLEVIS	
58056154	58056154	0	RESTORING SPRING	Utilizzato con motore GX200
58056593	58056593	0	SPRING	
58057263	58057263	0	CLAMPING SCREW	
58057284	58057284	0	LINE AND SHEATH	
58057285	58057285	0	LINE AND SHEATH	
58057287	58057287	0	LINE AND SHEATH	
58057288	58057288	0	LINE AND SHEATH	
58057329	58057329	0	LINE AND SHEATH	
58057342	58057342	0	LINE AND SHEATH	
58057401	58057401	0	WIRING	
58150313	58150313	0	CABLE CLAMP	
59047709	59047709	0	SWITCH SUPPORT	
59057116	59057116	0	COMPLETE HANDLE BAR	

DIESEL

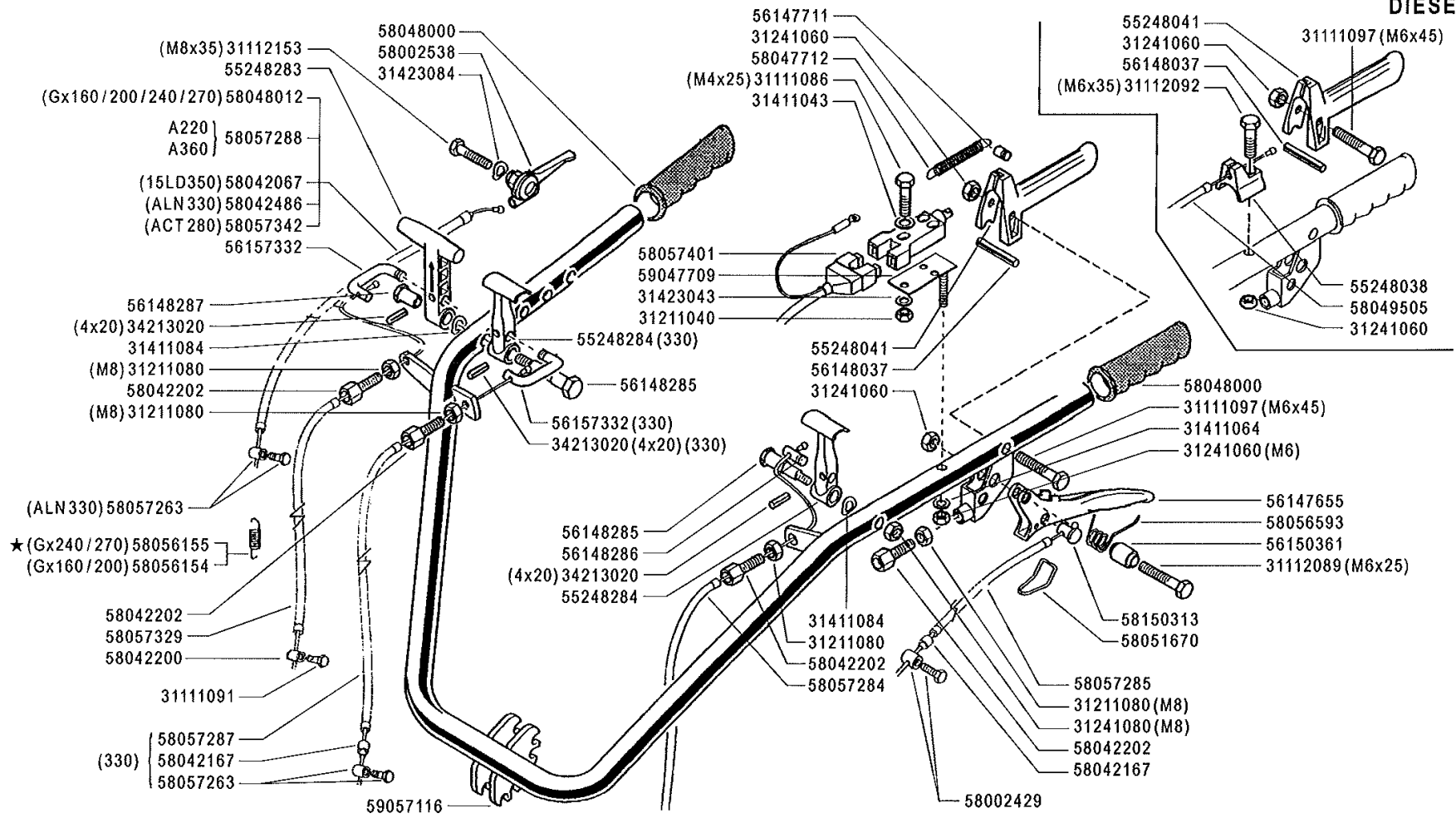

FERRARI

300 serie **95**

MANUBRIO (320-330)

HANDLEBAR
MANILLAR

MANCHERON
LENKER

DALLA MACCHINA
DE LA MAQUINA
DE LA MACHINE
FROM THE MACHINE
AB DER MASCHINE

AGGIORNAMENTO
REVISION
MISE A JOUR
APLAZAMIENTO
ANPASSUNG

Rev.
12
4
02/2006

★ N.

ZENNE

Pos.	Code	Q.ty	Description	Notes
31111086	31111086	1	SCREW TE M4X25 UNI 5739 8G	
31111091	31111091	1	SCREW E M6X14 UNI 5739 8G	
31111097	31111097	1	SCREW TE M6X45 UNI 5737 8G	
31112089	31112089	1	SCREW TE M6X25 UNI 5739 8G	
31112092	31112092	1	SCREW TE M6X35 UNI 5739 8G	
31112153	31112153	1	SCREW TE M8X35 UNI 5739 8G	
31211040	31211040	1	NUT M4	
31211080	31211080	1	NUT M8	
31241060	31241060	1	HEXAGON SELFLOCK NUT M6	
31241080	31241080	1	HEXAGON SELFLOCK NUT M8	
31411043	31411043	1	WASHER 4,3X9	
31411064	31411064	1	WASHER 6,4x12,5	
31411084	31411084	1	WASHER 8,4x17	
31423043	31423043	1	SPRING WASHER 4,3	
31423084	31423084	1	SPRING WASHER 8,4	
34213020	34213020	1	ROLL PIN	
55248038	55248038	1	STOP	
55248041	55248041	1	LEVER	
55248283	55248283	1	COMMAND LEVER	
55248284	55248284	1	LEVER	
56147655	56147655	1	CLUTCH LEVER	
56147711	56147711	1	PIN	
56148037	56148037	1	LEVER STOP	
56148285	56148285	1	PIN	
56148286	56148286	1	PIN	
56148287	56148287	1	STUD BOLT	
56150361	56150361	1	SPACER	
56157332	56157332	1	U BOLT	
58002429	58002429	1	CLAMPING SCREW	
58002538	58002538	1	COMMAND LEVER	
58042067	58042067	1	LINE AND SHEATH	
58042167	58042167	1	SHEATH TERMINAL	
58042200	58042200	1	CLAMPING SCREW	
58042202	58042202	1	ADJUSTING SCREW	

SERIAL

012_04 - HANDLEBAR (320-330)

CODE REV

012_4_25381

DIESEL

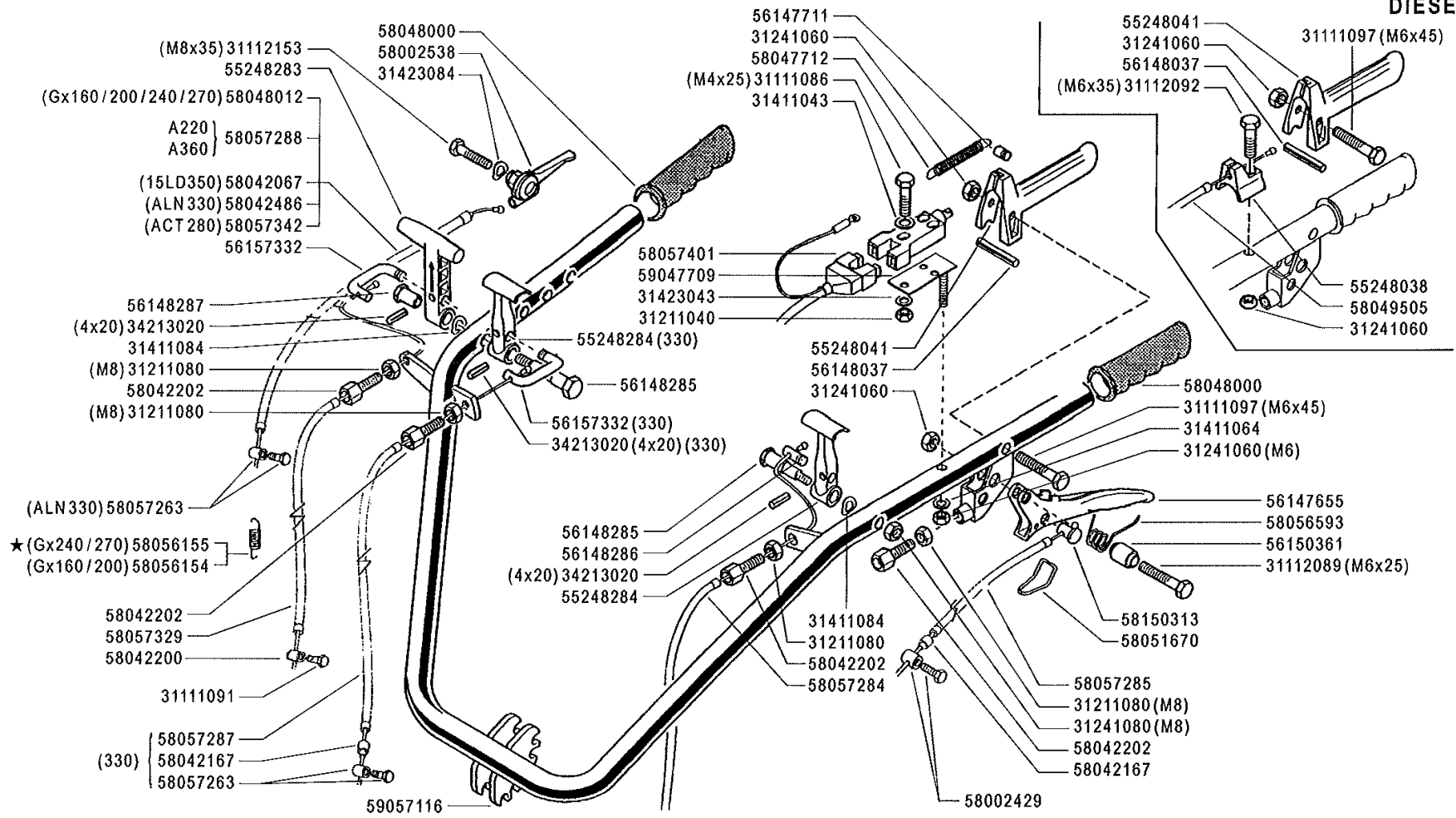

FERRARI

300 serie **95**

MANUBRIO (320-330)

HANDLEBAR
MANILLAR

MANCHERON
LENKER

DALLA MACCHINA
DE LA MAQUINA
DE LA MACHINE
FROM THE MACHINE
AB DER MASCHINE

AGGIORNAMENTO
REVISION
MISE A JOUR
APLAZAMIENTO
ANPASSUNG

Rev.
12
4
02/2006

★ N.

ZENNE

Pos.	Code	Q.ty	Description	Notes
58042486	58042486	1	LINE AND SHEATH	
58047712	58047712	1	SPRING	
58048000	58048000	1	KNOB	
58048012	58048012	1	LINE AND SHEATH	
58049505	58049505	1	LINE AND SHEATH	
58051670	58051670	1	CLEVIS	
58056154	58056154	1	RESTORING SPRING	Utilizzato con motore GX200
58056155	58056155	1	RESTORING SPRING	Utilizzato con motore GX270
58056593	58056593	1	SPRING	
58057263	58057263	1	CLAMPING SCREW	
58057284	58057284	1	LINE AND SHEATH	
58057285	58057285	1	LINE AND SHEATH	
58057287	58057287	1	LINE AND SHEATH	
58057288	58057288	1	LINE AND SHEATH	
58057329	58057329	1	LINE AND SHEATH	
58057342	58057342	1	LINE AND SHEATH	
58057401	58057401	1	WIRING	
58150313	58150313	1	CABLE CLAMP	
59047709	59047709	1	SWITCH SUPPORT	
59057116	59057116	1	COMPLETE HANDLE BAR	

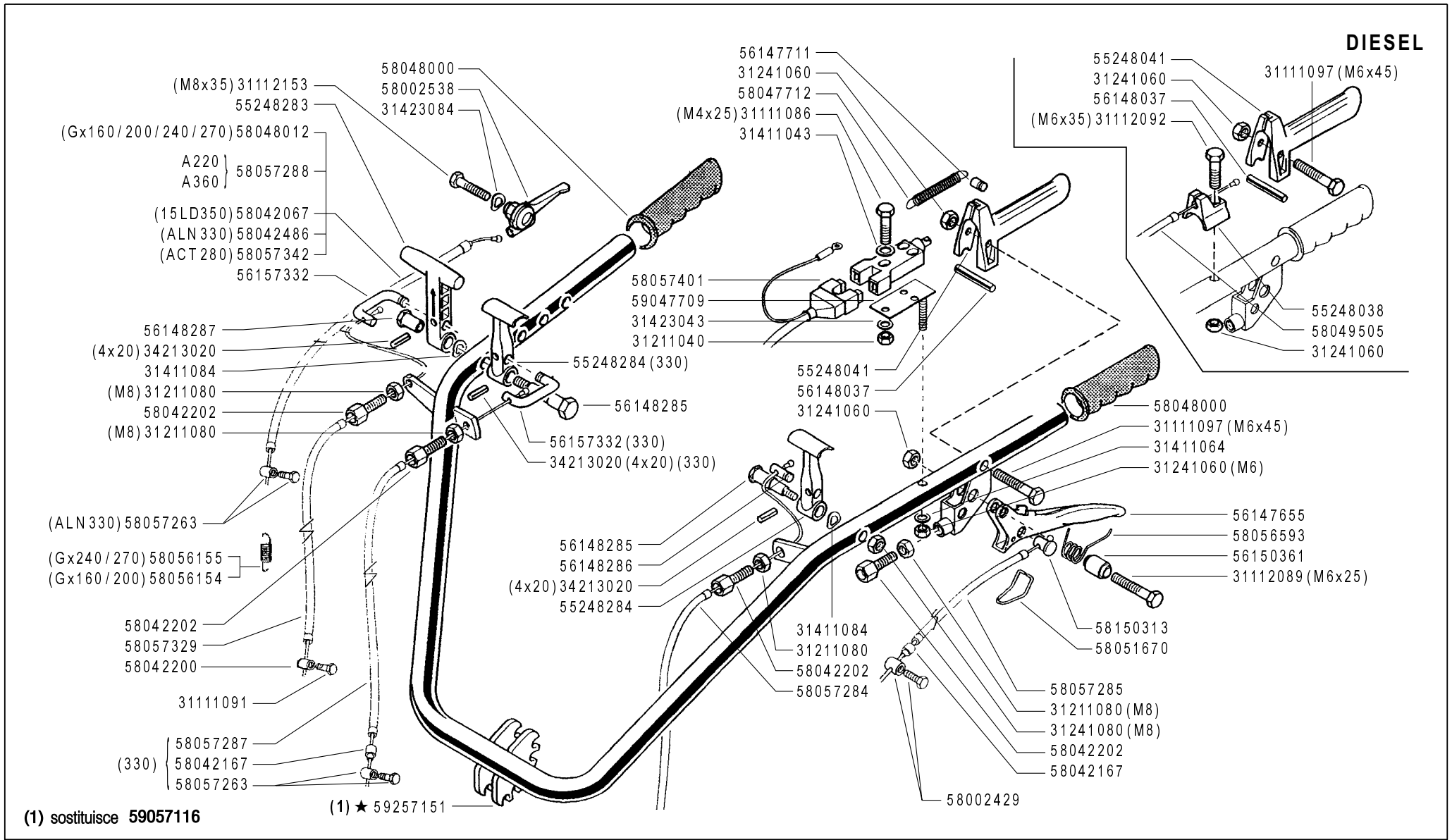

	300 serie 95	MANUBRIO (320-330) HANDLEBAR MANILLAR	DALLA MACCHINA DE LA MAQUINA FROM THE MACHINE AB DER MASCHINE ★N.	AGGIORNAMENTO	12	Rev.
				REVISION		5
				MISE A JOUR		
				APLAZAMIENTO		
				ANPASSUNG		
07/2006						

ZENNE

Pos.	Code	Q.ty	Description	Notes
31111086	31111086	1	SCREW TE M4X25 UNI 5739 8G	
31111091	31111091	1	SCREW E M6X14 UNI 5739 8G	
31111097	31111097	1	SCREW TE M6X45 UNI 5737 8G	
31112089	31112089	1	SCREW TE M6X25 UNI 5739 8G	
31112092	31112092	1	SCREW TE M6X35 UNI 5739 8G	
31112153	31112153	1	SCREW TE M8X35 UNI 5739 8G	
31211040	31211040	1	NUT M4	
31211080	31211080	1	NUT M8	
31241060	31241060	1	HEXAGON SELFLOCK NUT M6	
31241080	31241080	1	HEXAGON SELFLOCK NUT M8	
31411043	31411043	1	WASHER 4,3X9	
31411064	31411064	1	WASHER 6,4x12,5	
31411084	31411084	1	WASHER 8,4x17	
31423043	31423043	1	SPRING WASHER 4,3	
31423084	31423084	1	SPRING WASHER 8,4	
34213020	34213020	1	ROLL PIN	
55248038	55248038	1	STOP	
55248041	55248041	1	LEVER	
55248283	55248283	1	COMMAND LEVER	
55248284	55248284	1	LEVER	
56147655	56147655	1	CLUTCH LEVER	
56147711	56147711	1	PIN	
56148037	56148037	1	LEVER STOP	
56148285	56148285	1	PIN	
56148286	56148286	1	PIN	
56148287	56148287	1	STUD BOLT	
56150361	56150361	1	SPACER	
56157332	56157332	1	U BOLT	
58002429	58002429	1	CLAMPING SCREW	
58002538	58002538	1	COMMAND LEVER	
58042067	58042067	1	LINE AND SHEATH	
58042167	58042167	1	SHEATH TERMINAL	
58042200	58042200	1	CLAMPING SCREW	
58042202	58042202	1	ADJUSTING SCREW	

SERIAL

012_05 - HANDLEBAR (320-330)

CODE REV

012_5_32832

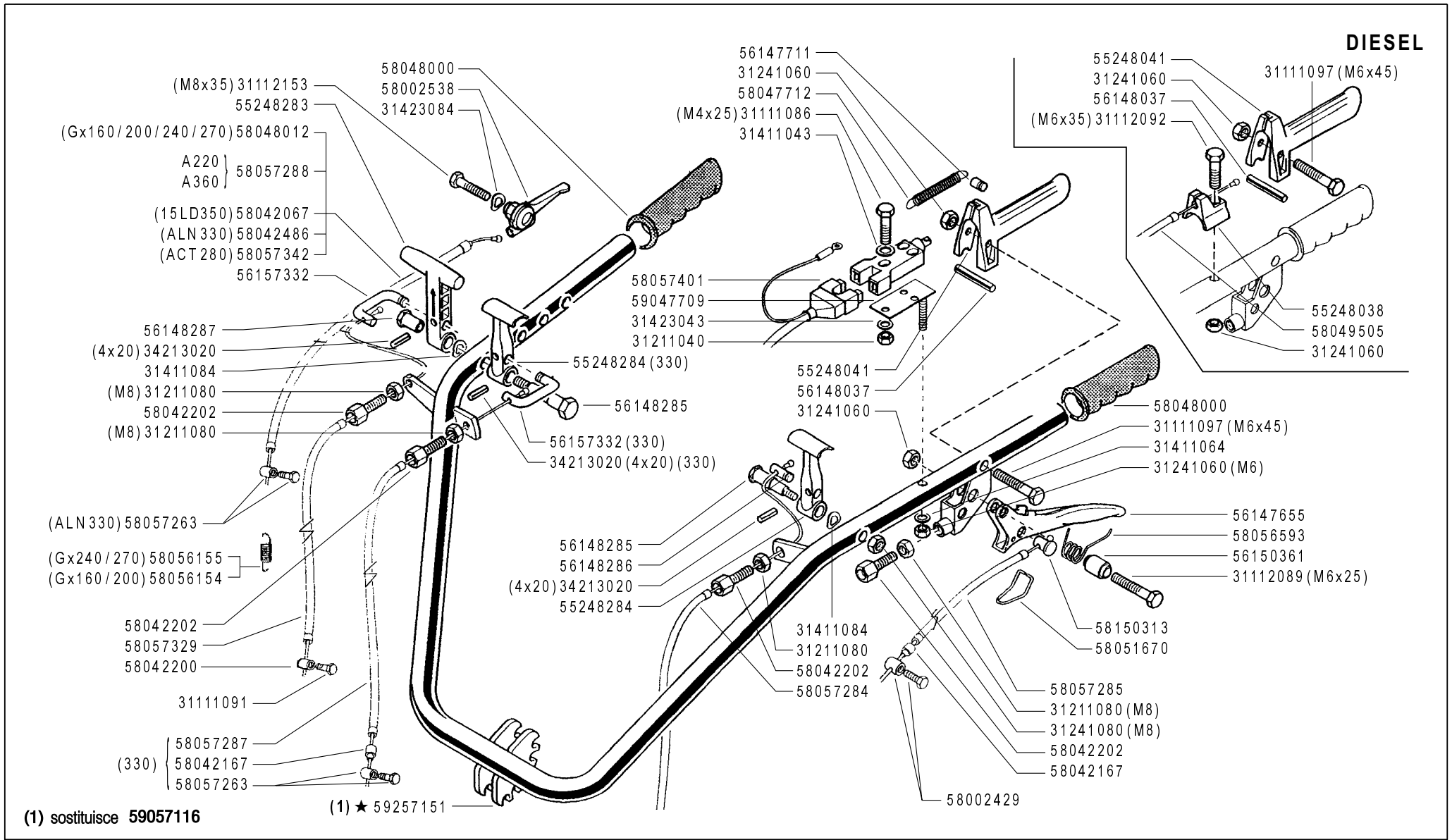

	300 serie 95	MANUBRIO (320-330) HANDLEBAR MANILLAR	DALLA MACCHINA DE LA MAQUINA FROM THE MACHINE AB DER MASCHINE	AGGIORNAMENTO	12	Rev.
				REVISION		5
				MISE A JOUR		
				APLAZAMIENTO		
				ANPASSUNG		
★N.	07/2006					

ZENNE

Pos.	Code	Q.ty	Description	Notes
58042486	58042486	1	LINE AND SHEATH	
58047712	58047712	1	SPRING	
58048000	58048000	1	KNOB	
58048012	58048012	1	LINE AND SHEATH	
58049505	58049505	1	LINE AND SHEATH	
58051670	58051670	1	CLEVIS	
58056154	58056154	1	RESTORING SPRING	Utilizzato con motore GX200
58056155	58056155	1	RESTORING SPRING	Utilizzato con motore GX270
58056593	58056593	1	SPRING	
58057263	58057263	1	CLAMPING SCREW	
58057284	58057284	1	LINE AND SHEATH	
58057285	58057285	1	LINE AND SHEATH	
58057287	58057287	1	LINE AND SHEATH	
58057288	58057288	1	LINE AND SHEATH	
58057329	58057329	1	LINE AND SHEATH	
58057342	58057342	1	LINE AND SHEATH	
58057401	58057401	1	WIRING	
58150313	58150313	1	CABLE CLAMP	
59047709	59047709	1	SWITCH SUPPORT	
59257151	59257151	1	COMPLETE HANDLE BAR	

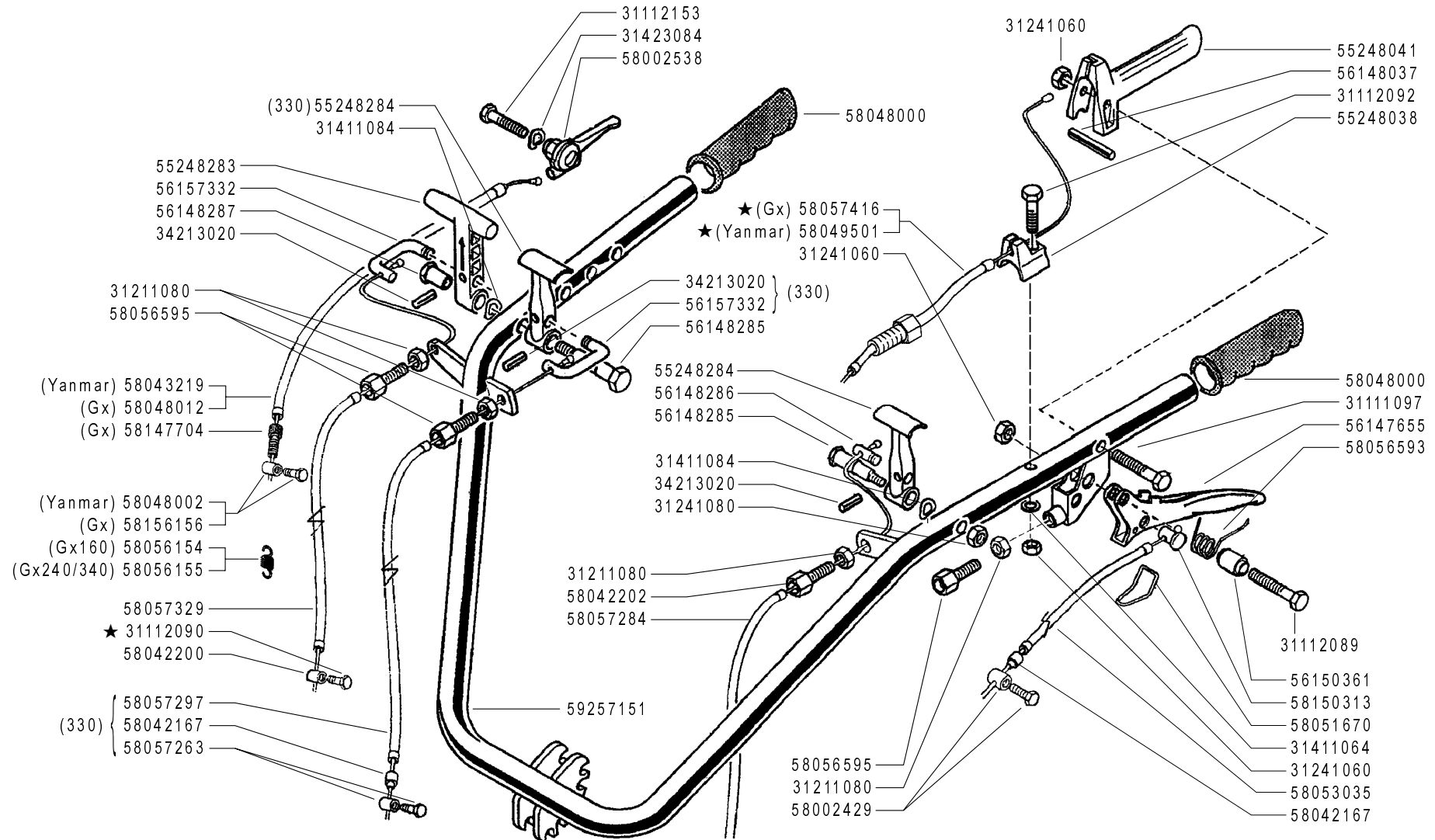

(1) sostituisce 58057286

FERRARI

300 serie **95**

MANUBRIO (320 - 330)

HANDLEBAR
MANILLAR

MANCHERON
LENKER

DALLA MACCHINA
DE LA MAQUINA
DE LA MACHINE
FROM THE MACHINE
AB DER MASCHINE

★N.

AGGIORNAMENTO
REVISION
MISE A JOUR
APLAZAMIENTO
ANPASSUNG

12 **6**

01/2008

Rev.

ZENNE

Pos.	Code	Q.ty	Description	Notes
31111097	31111097	1	SCREW TE M6X45 UNI 5737 8G	
31112089	31112089	1	SCREW TE M6X25 UNI 5739 8G	
31112090	31112090	1	SCREW TE M6X16 UNI 5739 8G	
31112092	31112092	1	SCREW TE M6X35 UNI 5739 8G	
31112153	31112153	1	SCREW TE M8X35 UNI 5739 8G	
31211080	31211080	1	NUT M8	
31241060	31241060	1	HEXAGON SELFLOCK NUT M6	
31241080	31241080	1	HEXAGON SELFLOCK NUT M8	
31411064	31411064	1	WASHER 6,4x12,5	
31411084	31411084	1	WASHER 8,4x17	
31423084	31423084	1	SPRING WASHER 8,4	
34213020	34213020	1	ROLL PIN	
55248038	55248038	1	STOP	
55248041	55248041	1	LEVER	
55248283	55248283	1	COMMAND LEVER	
55248284	55248284	1	LEVER	
56147655	56147655	1	CLUTCH LEVER	
56148037	56148037	1	LEVER STOP	
56148285	56148285	1	PIN	
56148286	56148286	1	PIN	
56148287	56148287	1	STUD BOLT	
56150361	56150361	1	SPACER	
56157332	56157332	1	U BOLT	
58002429	58002429	1	CLAMPING SCREW	
58002538	58002538	1	COMMAND LEVER	
58042167	58042167	1	SHEATH TERMINAL	
58042200	58042200	1	CLAMPING SCREW	
58042202	58042202	1	ADJUSTING SCREW	
58043219	58043219	1	LINE AND SHEATH	
58048000	58048000	1	KNOB	
58048002	58048002	1	CLAMPING SCREW	
58048012	58048012	1	LINE AND SHEATH	
58049501	58049501	1	LINE AND SHEATH	
58051670	58051670	1	CLEVIS	

SERIAL

012_06 - HANDLEBAR

CODE REV

012_6_64016

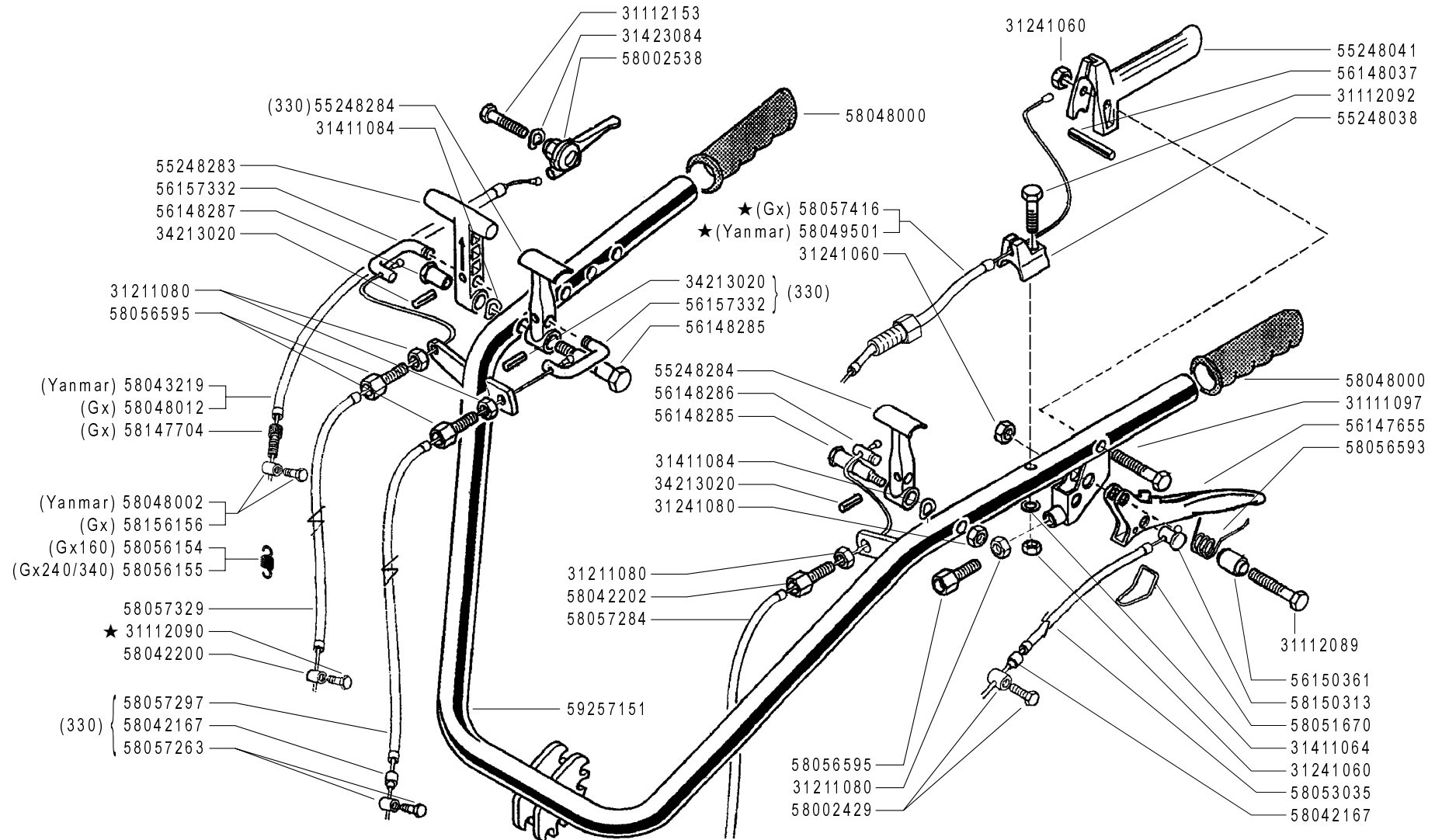

(1) sostituisce 58057286

FERRARI

300 serie **95**

MANUBRIO (320 - 330)

HANDLEBAR
MANILLAR

MANCHERON
LENKER

DALLA MACCHINA
DE LA MAQUINA
DE LA MACHINE
FROM THE MACHINE
AB DER MASCHINE

AGGIORNAMENTO
REVISION
MISE A JOUR
APLAZAMIENTO
ANPASSUNG

12 **6**

01/2008

★N.

ZENNE

Pos.	Code	Q.ty	Description	Notes
58053035	58053035	1	LINE AND SHEATH	
58056154	58056154	1	RESTORING SPRING	Utilizzato con motore GX200
58056155	58056155	1	RESTORING SPRING	Utilizzato con motore GX270
58056593	58056593	1	SPRING	
58056595	58056595	1	ADJUSTING SCREW	
58057263	58057263	1	CLAMPING SCREW	
58057284	58057284	1	LINE AND SHEATH	
58057297	58057297	1	LINE AND SHEATH	
58057329	58057329	1	LINE AND SHEATH	
58057416	58057416	1	LINE AND SHEATH	
58147704	58147704	1	ADJUSTING SCREW	
58150313	58150313	1	CABLE CLAMP	
58156156	58156156	1	TERMINAL	
59257151	59257151	1	COMPLETE HANDLE BAR	

	A	B	C	D
4.00 - 8"	391.14008	394.14008	G 580.43250	924.80719 (Kg .11)
4.0 - 10"	391.14010	394.14010	G 580.48330	924.80720 (Kg .15)
5.0-10"	391.15010	394.15010	G 580.48330	924.80720 (Kg .15)
5.00 - 12"	391.15012	394.15012	G 580.44804	924.80721 (Kg .34)
6.5/80-12"	391.16018	394.16018	G 580.44804	924.80721 (Kg .34)

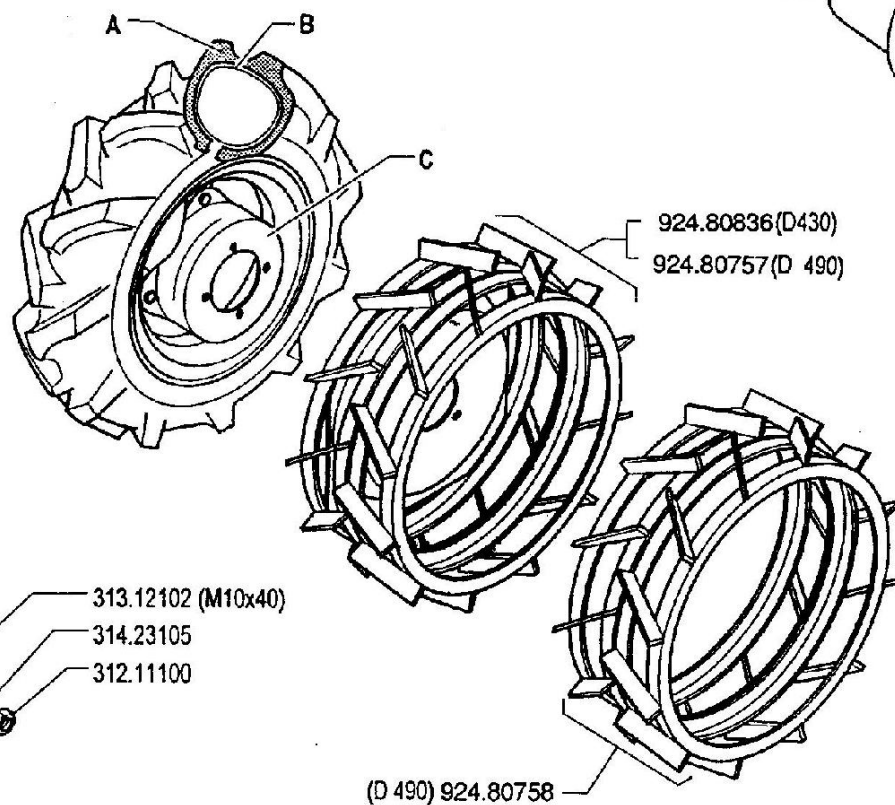
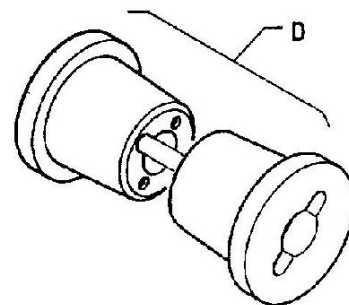

924.80718

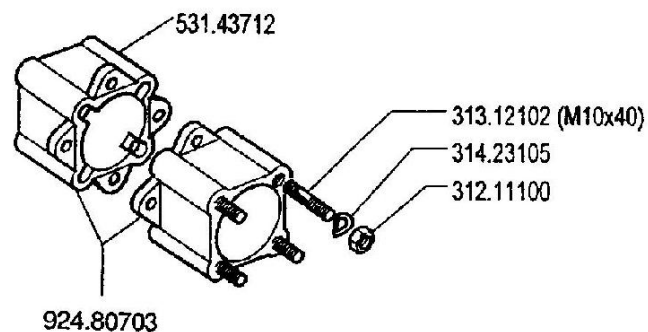
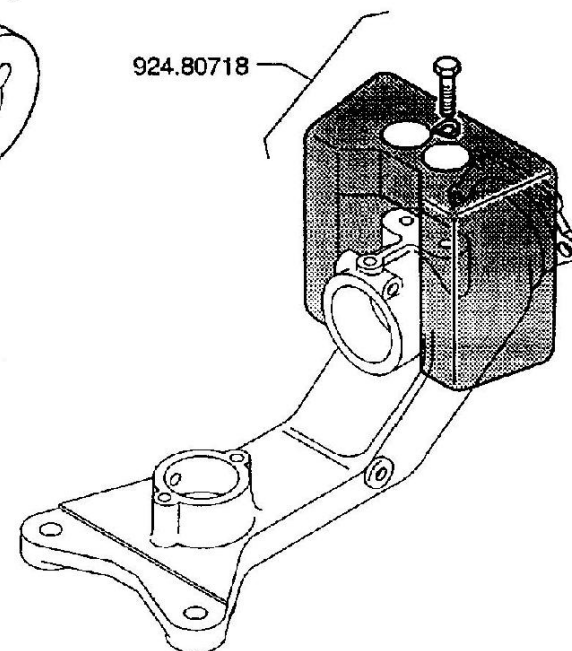

G = giallo - amarillo - jaune - yellow - gelb

FERRARI

300 serie **95**

RUEDAS
ROUES

RUOTE

WHEELS
RÄDER

DALLA MACCHINA
DE LA MAQUINA
DE LA MACHINE
FROM THE MACHINE
AB DER MASCHINE

15.00

N.

01.06.1995

Pos.	Code	Q.ty	Description	Notes
31211100	31211100	0	NUT M10	
31312102	31312102	0	STUD BOLT M10X40X24X12	
31423105	31423105	0	SPRING WASHER 10,5	
39114008	39114008	0	TYRE 4.00-8 2PR	
39114010	39114010	0	TYRE 4.0-10 2PR	
39115010	39115010	0	TYRE 5.00-10 2PR	
39115012	39115012	0	TYRE 5.00-12 2PR	
39116018	39116018	0	TYRE 6.5/80-12 2PR	
39414008	39414008	0	INNER TUBE	
39414010	39414010	0	INNER TUBE	
39415010	39415010	0	INNER TUBE	
39415012	39415012	0	INNER TUBE	
39416018	39416018	0	INNER TUBE	
53143712	53143712	0	SPACER	
58043250	58043250	0	RIM	
58044804	58044804	0	RIM	
58048330	58048330	0	RIM	
92480703	92480703	0	SPACER CM. 6 FOR WHEELS (PAIR)(0901012301)	
92480718	92480718	0	WEIGHT KG. 12 FOR CUTTER BAR FOR 90SLB/305/306/307/792/794	
92480719	92480719	0	WEIGHTS KG. 11 FOR WHEELS 4.00-8 FOR 305/306 (PAIR)	
92480720	92480720	0	WEIGHTS KG. 15 FOR WHEELS 4.0-10 AND 5.0-10 FOR 305/306/307 (PAIR)	
92480721	92480721	0	WEIGHTS KG. 34 FOR WHEELS 5.00-12 / 6.5/80-12 (PAIR) (0901012307)	
92480757	92480757	0	CAGE WHEELS DIAM. CM. 49 FOR 306/30 (PAIR) (0901012315)	
92480758	92480758	0	ADAPTER RINGS FOR MOUNTING STEEL CAGE WHEELS CM. 49 (PAIR)	
92480836	92480836	0	STEEL CAGE WHEELS DIAM. 43 CM.	

	A	B	C ★	D
4.00 - 8"	391.14008	394.14008	580.52326	924.80719 (Kg .11)
4.0 - 10"	391.14010	394.14010	580.52327	924.80720 (Kg .15)
5.0-10"	391.15010	394.15010	580.52327	924.80720 (Kg. 15)
5.00 - 12"	391.15012	394.15012	580.52328	924.80721 (Kg .34)
6.5/80-12"	391.16018	394.16018	580.52328	924.80721 (Kg .34)

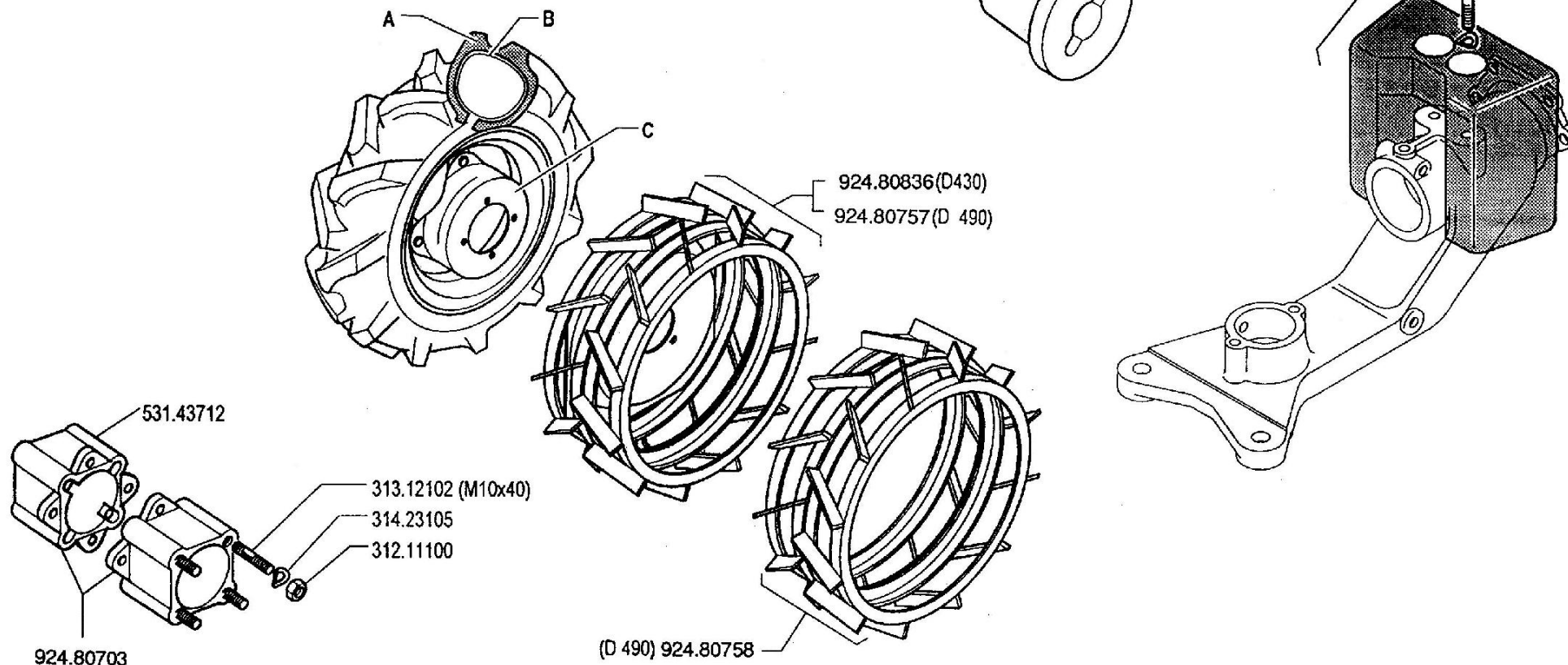

FERRARI

300 serie **95**

RUOTE

WHEELS
RUEDAS

ROUES
RÄDER

DALLA MACCHINA
DE LA MAQUINA
DE LA MACHINE
FROM THE MACHINE
AB DER MASCHINE

AGGIORNAMENTO

REVISION

MISE A JOUR

APLAZAMIENTO

ANPASSUNG

15

01

11/1996

★N.

ZENITE

Pos.	Code	Q.ty	Description	Notes
31211100	31211100	0	NUT M10	
31312102	31312102	0	STUD BOLT M10X40X24X12	
31423105	31423105	0	SPRING WASHER 10,5	
39114008	39114008	0	TYRE 4.00-8 2PR	
39114010	39114010	0	TYRE 4.0-10 2PR	
39115010	39115010	0	TYRE 5.00-10 2PR	
39115012	39115012	0	TYRE 5.00-12 2PR	
39116018	39116018	0	TYRE 6.5/80-12 2PR	
39414008	39414008	0	INNER TUBE	
39414010	39414010	0	INNER TUBE	
39415010	39415010	0	INNER TUBE	
39415012	39415012	0	INNER TUBE	
39416018	39416018	0	INNER TUBE	
53143712	53143712	0	SPACER	
58052326	58052326	0	RIM	
58052327	58052327	0	RIM	
58052328	58052328	0	RIM	
92480703	92480703	0	SPACER CM. 6 FOR WHEELS (PAIR)(0901012301)	
92480718	92480718	0	WEIGHT KG. 12 FOR CUTTER BAR FOR 90SLB/305/306/307/792/794	
92480719	92480719	0	WEIGHTS KG. 11 FOR WHEELS 4.00-8 FOR 305/306 (PAIR)	
92480720	92480720	0	WEIGHTS KG. 15 FOR WHEELS 4.0-10 AND 5.0-10 FOR 305/306/307 (PAIR)	
92480721	92480721	0	WEIGHTS KG. 34 FOR WHEELS 5.00-12 / 6.5/80-12 (PAIR) (0901012307)	
92480757	92480757	0	CAGE WHEELS DIAM. CM. 49 FOR 306/30 (PAIR) (0901012315)	
92480758	92480758	0	ADAPTER RINGS FOR MOUNTING STEEL CAGE WHEELS CM. 49 (PAIR)	
92480836	92480836	0	STEEL CAGE WHEELS DIAM. 43 CM.	

	A	B	C	D
4.00 - 8"	391.14008	394.14008	580.52326	924.80719 (Kg .11)
4.0 - 10"	391.14010	394.14010	580.52327	924.80720 (Kg .15)
5.0-10"	391.15010	394.15010	580.52327	924.80720 (Kg .15)
5.00 - 12"	391.15012	394.15012	580.52328	924.80721 (Kg .34)
6.5/80-12"	391.16018	394.16018	580.52328	924.80721 (Kg .34)

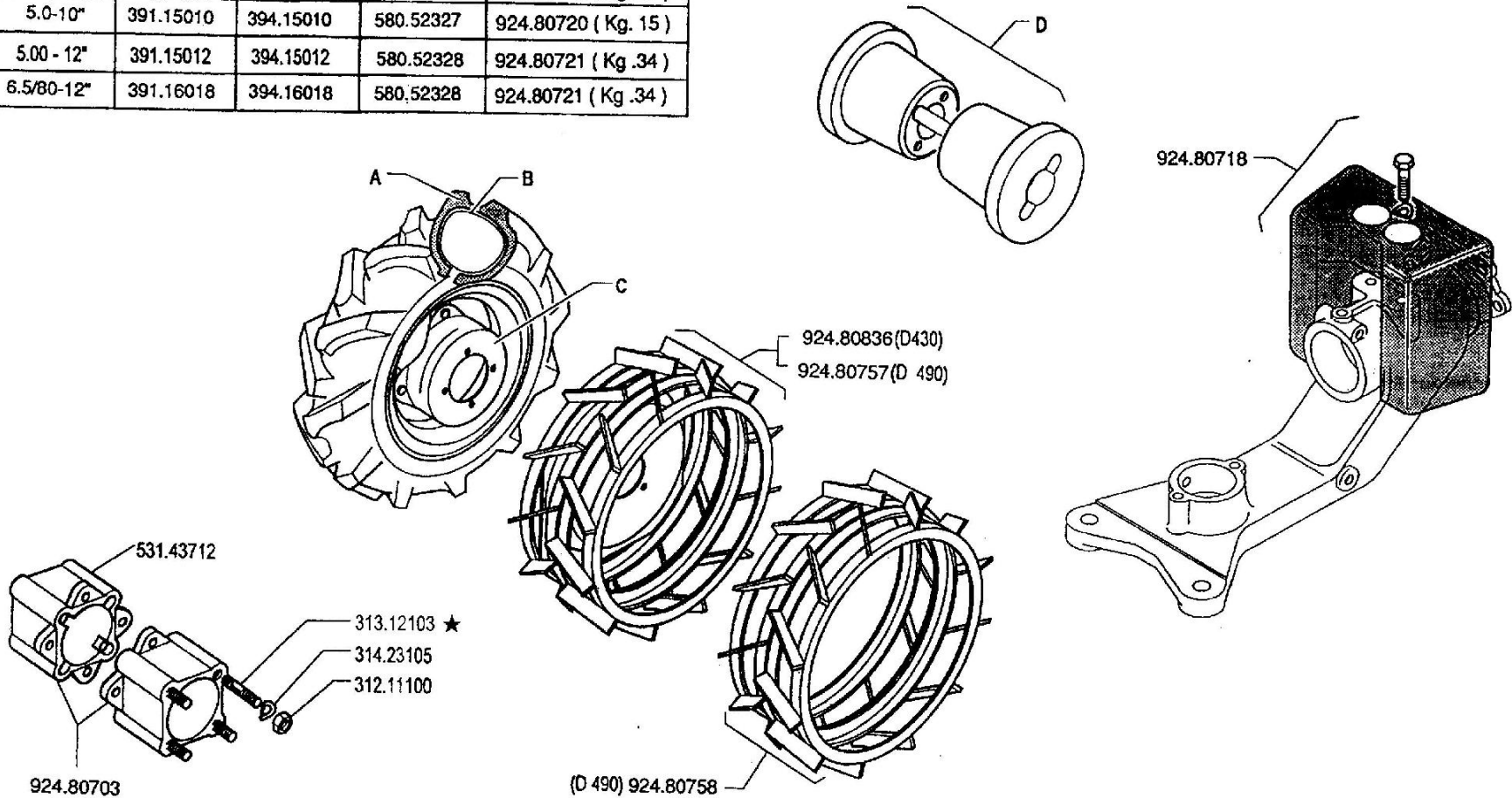

FERRARI

300 serie **95**

RUOTE

WHEELS
RUEDAS

ROUES
RÄDER

DALLA MACCHINA
DE LA MAQUINA
DE LA MACHINE
FROM THE MACHINE
AB DER MASCHINE

AGGIORNAMENTO
REVISION
MISE A JOUR
APLAZAMIENTO
ANPASSUNG

15

11/1999

Rev.
2

★N

ZENVE

Pos.	Code	Q.ty	Description	Notes
31211100	31211100	0	NUT M10	
31312103	31312103	0	STUD BOLT M10X46X24X16	
31423105	31423105	0	SPRING WASHER 10,5	
39114008	39114008	0	TYRE 4.00-8 2PR	
39114010	39114010	0	TYRE 4.0-10 2PR	
39115010	39115010	0	TYRE 5.00-10 2PR	
39115012	39115012	0	TYRE 5.00-12 2PR	
39116018	39116018	0	TYRE 6.5/80-12 2PR	
39414008	39414008	0	INNER TUBE	
39414010	39414010	0	INNER TUBE	
39415010	39415010	0	INNER TUBE	
39415012	39415012	0	INNER TUBE	
39416018	39416018	0	INNER TUBE	
53143712	53143712	0	SPACER	
58052326	58052326	0	RIM	
58052327	58052327	0	RIM	
58052328	58052328	0	RIM	
92480703	92480703	0	SPACER CM. 6 FOR WHEELS (PAIR)(0901012301)	
92480718	92480718	0	WEIGHT KG. 12 FOR CUTTER BAR FOR 90SLB/305/306/307/792/794	
92480719	92480719	0	WEIGHTS KG. 11 FOR WHEELS 4.00-8 FOR 305/306 (PAIR)	
92480720	92480720	0	WEIGHTS KG. 15 FOR WHEELS 4.0-10 AND 5.0-10 FOR 305/306/307 (PAIR)	
92480721	92480721	0	WEIGHTS KG. 34 FOR WHEELS 5.00-12 / 6.5/80-12 (PAIR) (0901012307)	
92480757	92480757	0	CAGE WHEELS DIAM. CM. 49 FOR 306/30 (PAIR) (0901012315)	
92480758	92480758	0	ADAPTER RINGS FOR MOUNTING STEEL CAGE WHEELS CM. 49 (PAIR)	
92480836	92480836	0	STEEL CAGE WHEELS DIAM. 43 CM.	

	A	B	C	D
4.00-8"	39114008	39414008	58052326	92480719 (kg.11)
4.0-10"	39114010	39414010	58052327	92480720 (kg.15)
4.0-10"	39114010	39414010	58052288 (FIX)	/
5.0-10"	39115010	39415010	58052327	92480720 (kg.15)
5.0-10"	39115010	39415010	58052288 (FIX)	/
5.00-12"	39115012	39415012	58052328	92480721 (kg.34)
6.5/80-12"	39116018	39416018	58052328	92480721 (kg.34)

★

★

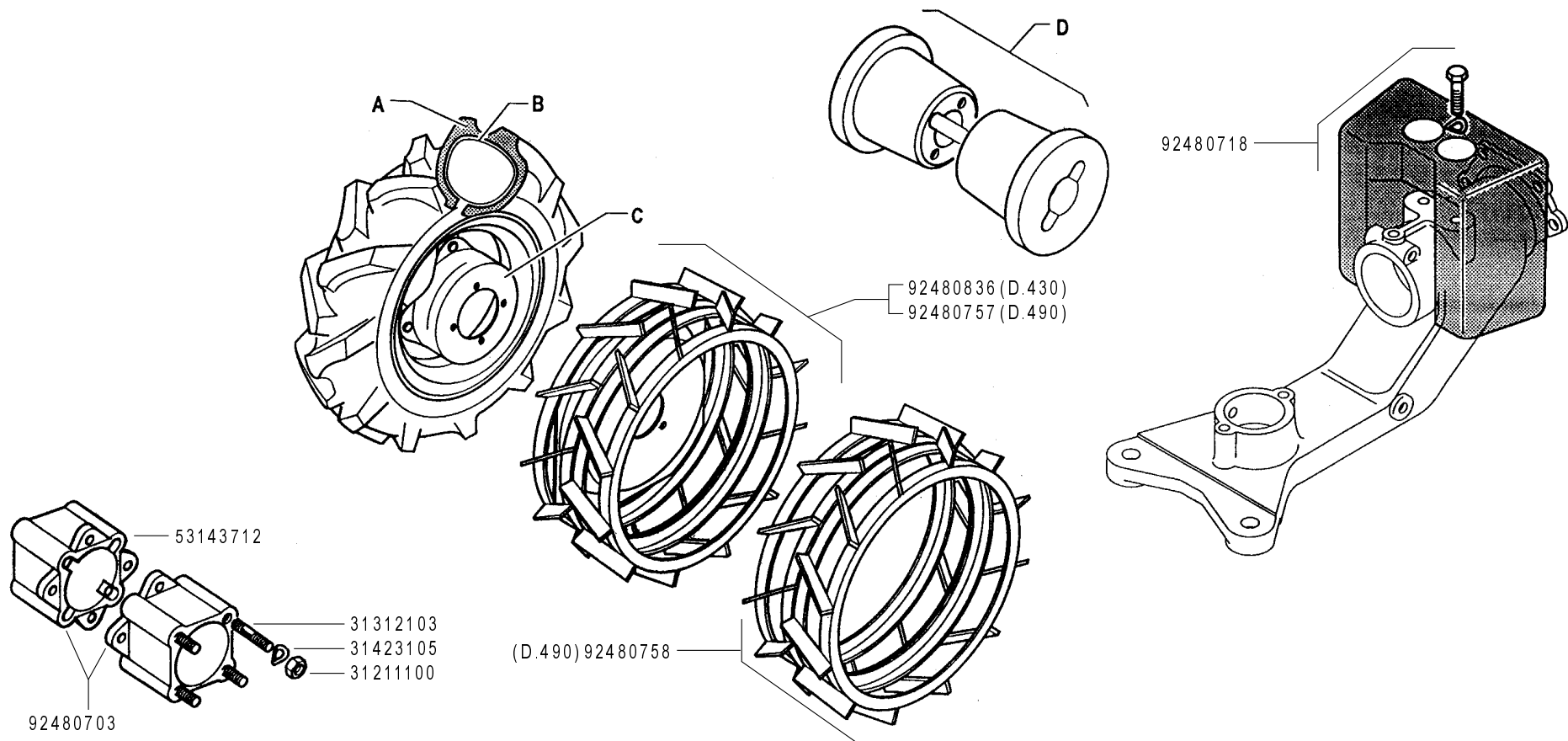
FERRARI
300 serie **95**
RUOTE

 WHEELS
 RUEDAS

 ROUES
 RÄDER

 DALLA MACCHINA
 DE LA MAQUINA
 DE LA MACHINE
 FROM THE MACHINE
 AB DER MASCHINE

★ N.

AGGIORNAMENTO

REVISION

MISE A JOUR

APLAZAMIENTO

ANPASSUNG

15

 Rev.
3
01/2008

ZENNE

Pos.	Code	Q.ty	Description	Notes
31211100	31211100	1	NUT M10	
31312103	31312103	1	STUD BOLT M10X46X24X16	
31423105	31423105	1	SPRING WASHER 10,5	
39114008	39114008	1	TYRE 4.00-8 2PR	
39114010	39114010	1	TYRE 4.0-10 2PR	
39115010	39115010	1	TYRE 5.00-10 2PR	
39115012	39115012	1	TYRE 5.00-12 2PR	
39116018	39116018	1	TYRE 6.5/80-12 2PR	
39414008	39414008	1	INNER TUBE	
39414010	39414010	1	INNER TUBE	
39415010	39415010	1	INNER TUBE	
39415012	39415012	1	INNER TUBE	
39416018	39416018	1	INNER TUBE	
53143712	53143712	1	SPACER	
58052288	58052288	1	RIM	
58052326	58052326	1	RIM	
58052327	58052327	1	RIM	
58052328	58052328	1	RIM	
92480703	92480703	1	SPACER CM. 6 FOR WHEELS (PAIR)(0901012301)	
92480718	92480718	1	WEIGHT KG. 12 FOR CUTTER BAR FOR 90SLB/305/306/307/792/794	
92480719	92480719	1	WEIGHTS KG. 11 FOR WHEELS 4.00-8 FOR 305/306 (PAIR)	
92480720	92480720	1	WEIGHTS KG. 15 FOR WHEELS 4.0-10 AND 5.0-10 FOR 305/306/307 (PAIR)	
92480721	92480721	1	WEIGHTS KG. 34 FOR WHEELS 5.00-12 / 6.5/80-12 (PAIR) (0901012307)	
92480757	92480757	1	CAGE WHEELS DIAM. CM. 49 FOR 306/30 (PAIR) (0901012315)	
92480758	92480758	1	ADAPTER RINGS FOR MOUNTING STEEL CAGE WHEELS CM. 49 (PAIR)	
92480836	92480836	1	STEEL CAGE WHEELS DIAM. 43 CM.	

340 580.52013

FERRARI 580.52019

320 580.52025

320 580.52026

330 580.52027

330 580.52028

FERRARI 580.52029

310 580.52035

310 580.52036

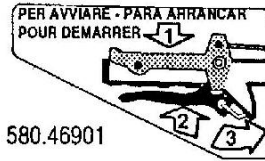

580.46901

FRIZIONE
EMBRAYAGE
EMBRAGUE 580.46903



580.46912



580.57677

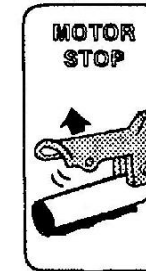

580.46902

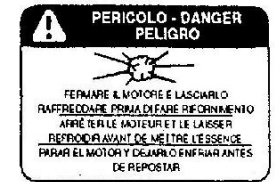

580.46909



580.57676



580.46910



580.46913



580.57678



580.57688

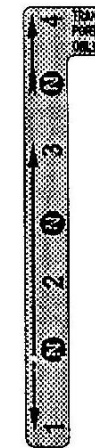

580.57704

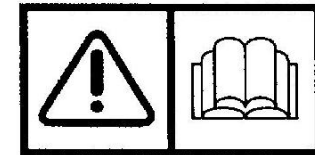

580.57724

FERRARI

300 serie 95

STICKERS
ADHESIVOS

ADESIVI

AUTOCOLLANTS
AUFKLEBES

DALLA MACCHINA
DE LA MAQUINA
DE LA MACHINE
FROM THE MACHINE
AB DER MASCHINE

N.

16 00

9/1997

ZENNE

Pos.	Code	Q.ty	Description	Notes
58046901	58046901	0	DECAL	
58046902	58046902	0	DECAL	
58046903	58046903	0	DECAL	
58046909	58046909	0	DECAL	
58046910	58046910	0	DECAL	
58046912	58046912	0	DECAL	
58046913	58046913	0	DECAL	
58052013	58052013	0	DECAL	
58052019	58052019	0	DECAL	
58052025	58052025	0	DECAL	
58052026	58052026	0	DECAL	
58052027	58052027	0	DECAL	
58052028	58052028	0	DECAL	
58052029	58052029	0	DECAL	
58052035	58052035	0	DECAL	
58052036	58052036	0	DECAL	
58057676	58057676	0	DECAL	
58057677	58057677	0	DECAL	
58057678	58057678	0	DECAL	
58057688	58057688	0	DECAL	
58057704	58057704	0	DECAL	
58057724	58057724	0	DECAL	



580.52019



580.52029

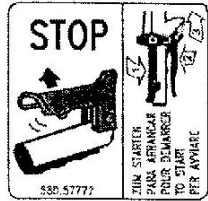

580.57772★

580.57770 KUPPLUNG
EMBRAYAGE
EMBRAGUE
CLUTCH
FRIZIONE

580.57770★

340

- 580.52013
- 580.52026
- 580.52028
- 580.52035
- 580.52036
- 580.52027
- 580.52025

320

320

330

330

310

310



580.57677

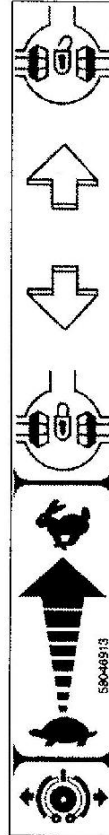

580.46913
580.57678

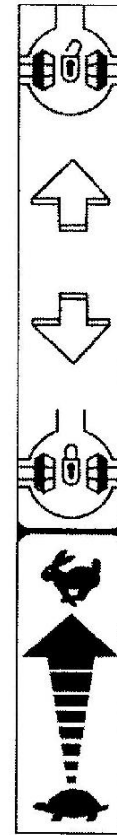

580.57688

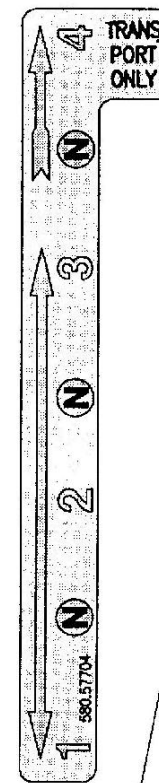

580.57704
★ 580.57768
★ 580.57767
580.57676
580.46912

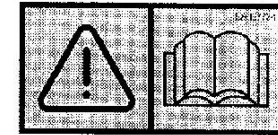

580.57724

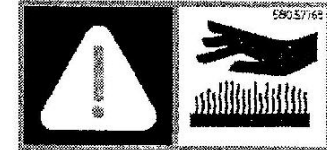

300 serie 95

STICKERS
ADHESIVOS

ADESIVI

AUTOCOLLANTS
AUFKLEBES

DALLA MACCHINA
DE LA MAQUINA
DE LA MACHINE
FROM THE MACHINE
AB DER MASCHINE

AGGIORNAMENTO
REVISION
MISE A JOUR
APLAZAMIENTO
ANPASSUNG

16

12/2003

Rev.
1

★N

ZERNE

Pos.	Code	Q.ty	Description	Notes
58046912	58046912	0	DECAL	
58046913	58046913	0	DECAL	
58052013	58052013	0	DECAL	
58052019	58052019	0	DECAL	
58052025	58052025	0	DECAL	
58052026	58052026	0	DECAL	
58052027	58052027	0	DECAL	
58052028	58052028	0	DECAL	
58052029	58052029	0	DECAL	
58052035	58052035	0	DECAL	
58052036	58052036	0	DECAL	
58057676	58057676	0	DECAL	
58057677	58057677	0	DECAL	
58057678	58057678	0	DECAL	
58057688	58057688	0	DECAL	
58057704	58057704	0	DECAL	
58057724	58057724	0	DECAL	
58057767	58057767	0	DECAL	
58057768	58057768	0	DECAL	
58057770	58057770	0	DECAL	
58057772	58057772	0	DECAL	



58057772



58057770

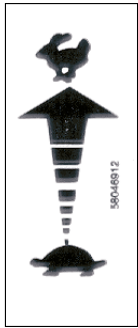

58046912

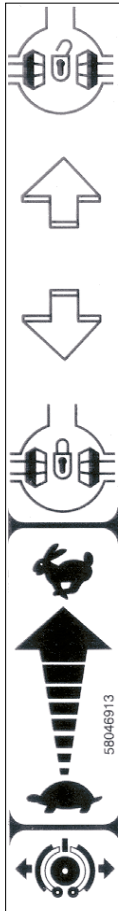

58046913

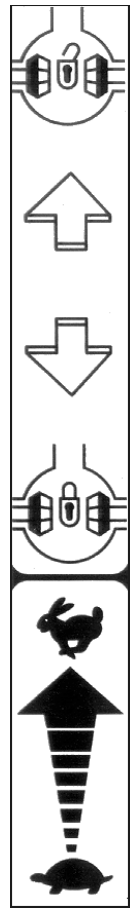

58057688



58057677



58057678

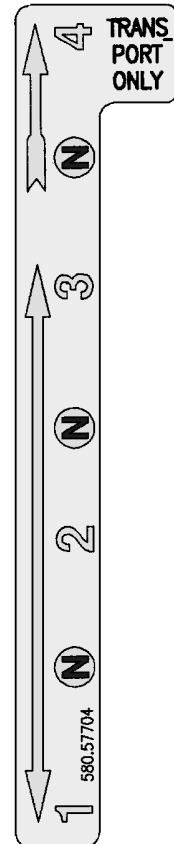

58057704

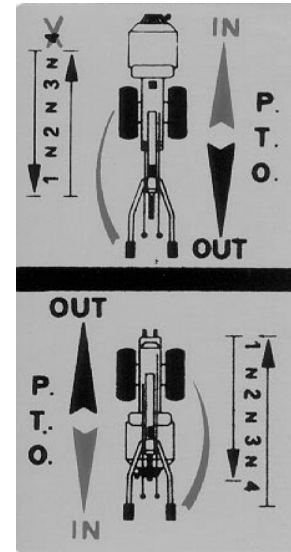

58047729 ★



58057724



58057768



58057767

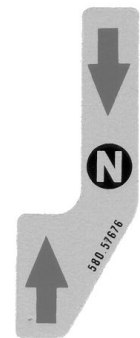

58057676

FERRARI

300 serie **95**

ADESIVI

STICKERS
ADHESIVOS

AUTOCOLLANTS
AUFKLEBES

DALLA MACCHINA
DE LA MAQUINA
DE LA MACHINE
FROM THE MACHINE
AB DER MASCHINE

AGGIORNAMENTO
REVISION
MISE A JOUR
APLAZAMIENTO
ANPASSUNG

16

Rev.
2

02/2006

★N.

ZENNE

Pos.	Code	Q.ty	Description	Notes
58046912	58046912	1	DECAL	
58046913	58046913	1	DECAL	
58047729	58047729	1	DECAL	
58057676	58057676	1	DECAL	
58057677	58057677	1	DECAL	
58057678	58057678	1	DECAL	
58057688	58057688	1	DECAL	
58057704	58057704	1	DECAL	
58057724	58057724	1	DECAL	
58057767	58057767	1	DECAL	
58057768	58057768	1	DECAL	
58057770	58057770	1	DECAL	
58057772	58057772	1	DECAL	

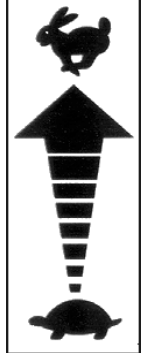
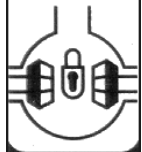
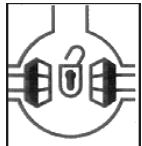

58057688



58057767

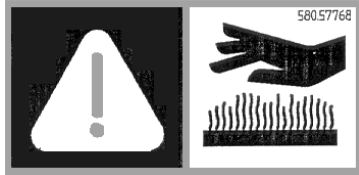

58057768

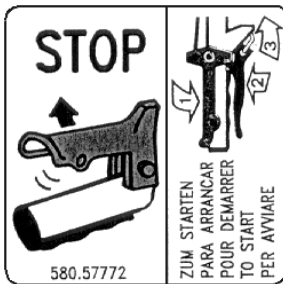

58057772



58057724

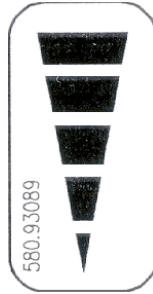

58093089



58057746

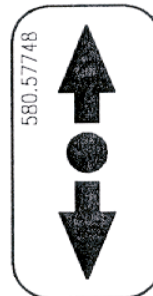

58057748

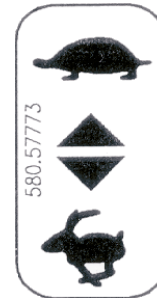

58057773

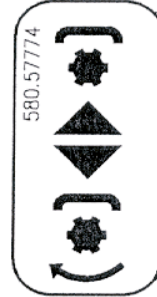

58057774

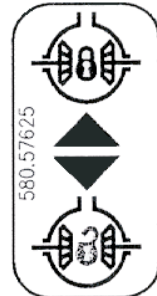

58057625

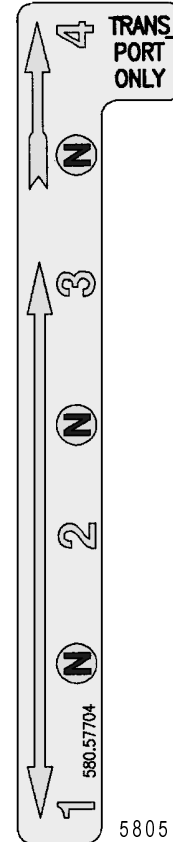

58057704



58057770

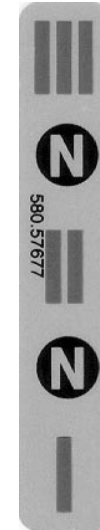

58057677

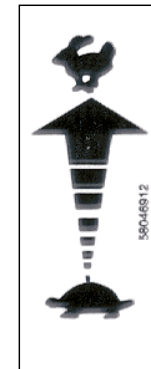

58046912



58057678

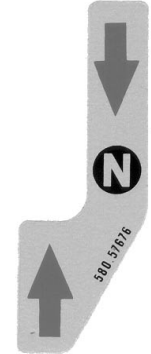

58057676

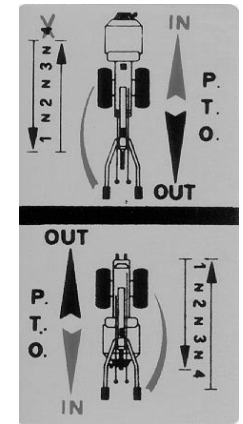

58047729

FERRARI

300 serie 95

STICKERS
ADHESIVOS

ADESIVI

AUTOCOLLANTS
AUFKLEBES

DALLA MACCHINA
DE LA MAQUINA
FROM THE MACHINE
AB DER MASCHINE

AGGIORNAMENTO

REVISION

MISE A JOUR

APLAZAMIENTO

ANPASSUNG

★N.

16

07/2006

Rev.
3

ZENNE

Pos.	Code	Q.ty	Description	Notes
58046912	58046912	1	DECAL	
58047729	58047729	1	DECAL	
58057625	58057625	1	DECAL	
58057676	58057676	1	DECAL	
58057677	58057677	1	DECAL	
58057678	58057678	1	DECAL	
58057688	58057688	1	DECAL	
58057704	58057704	1	DECAL	
58057724	58057724	1	DECAL	
58057746	58057746	1	DECAL	
58057748	58057748	1	DECAL	
58057767	58057767	1	DECAL	
58057768	58057768	1	DECAL	
58057770	58057770	1	DECAL	
58057772	58057772	1	DECAL	
58057773	58057773	1	DECAL	
58057774	58057774	1	DECAL	
58093089	58093089	1	DECAL	

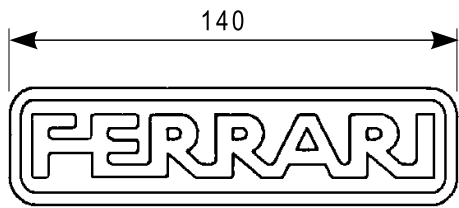

58052029

310

58052035

310

58052036



58052019

320

58052026

320

58052025

330

58052028

330

58052027

346

58052152 ★

340

58052013

FERRARI

300 serie **95**

ADESIVI

STICKERS
ADHESIVOS

AUTOCOLLANTS
AUFKLEBES

DALLA MACCHINA
DE LA MAQUINA
DE LA MACHINE
FROM THE MACHINE
AB DER MASCHINE

★ **N.**

AGGIORNAMENTO
REVISION
MISE A JOUR
APLAZAMIENTO
ANPASSUNG

17

Rev.
0

02/2006

ZENNE

Pos.	Code	Q.ty	Description	Notes
58052013	58052013	1	DECAL	
58052019	58052019	1	DECAL	
58052025	58052025	1	DECAL	
58052026	58052026	1	DECAL	
58052027	58052027	1	DECAL	
58052028	58052028	1	DECAL	
58052029	58052029	1	DECAL	
58052035	58052035	1	DECAL	
58052036	58052036	1	DECAL	
58052152	58052152	1	DECAL	

SPARE PARTS INSTANCE INDEX





SPARE PARTS INSTANCE INDEX

Code	Parts Table	Pos.	Q.ty	Code	Parts Table	Pos.	Q.ty	Code	Parts Table	Pos.	Q.ty
30000276	002_0_10478	30000276	0	31100003	003_5_33490	31100003	1	31111097	012_5_32832	31111097	1
	002_1_10500	30000276	0	31100015	003_3_25078	31100015	1		012_6_64016	31111097	1
30000277	002_0_10478	30000277	0		003_4_27606	31100015	1	31111151	01A_0_12068	31111151	0
	002_1_10500	30000277	0		003_5_33490	31100015	1		01A_1_12095	31111151	0
30000551	002_0_10478	30000551	0	31100786	003_0_10557	31100786	0		01A_2_12123	31111151	0
	002_1_10500	30000551	0		003_1_10576	31100786	0		01A_3_12154	31111151	0
30000612	10A_0_12219	30000612	0		003_2_10596	31100786	0		01A_4_24894	31111151	0
	10A_1_12244	30000612	0		003_3_25078	31100786	1	31111165	012_0_11498	31111165	0
	10A_2_12281	30000612	0	31100787	003_0_10557	31100787	0	31111217	010_1_11182	31111217	0
	10A_3_12322	30000612	0		003_1_10576	31100787	0		010_2_11218	31111217	0
30000628	01A_0_12068	30000628	0		003_2_10596	31100787	0	31111229	10A_0_12219	31111229	0
	01A_1_12095	30000628	0		003_3_25078	31100787	1		10A_1_12244	31111229	0
	01A_2_12123	30000628	0	31104020	003_3_25078	31104020	1		10A_2_12281	31111229	0
	01A_3_12154	30000628	0	31111086	012_0_11498	31111086	0		10A_3_12322	31111229	0
	01A_4_24894	30000628	0		012_1_11547	31111086	0		10A_4_63871	31111229	1
	10A_0_12219	30000628	0		012_2_11597	31111086	0	31112089	012_0_11498	31112089	0
	10A_1_12244	30000628	0		012_3_11651	31111086	0		012_1_11547	31112089	0
30000629	01A_0_12068	30000629	0		012_4_25381	31111086	1		012_2_11597	31112089	0
	01A_1_12095	30000629	0		012_5_32832	31111086	1		012_3_11651	31112089	0
	01A_2_12123	30000629	0		10A_4_63871	31111086	1		012_4_25381	31112089	1
	01A_3_12154	30000629	0	31111090	004_0_10617	31111090	0		012_5_32832	31112089	1
	01A_4_24894	30000629	0		004_1_10650	31111090	0		012_6_64016	31112089	1
30010142	010_1_11182	30010142	0		004_2_10685	31111090	0	31112090	012_1_11547	31112090	0
	010_2_11218	30010142	0		004_3_10722	31111090	0		012_6_64016	31112090	1
30040001	004_0_10617	30040001	0		004_4_25109	31111090	1	31112092	012_0_11498	31112092	0
	004_1_10650	30040001	0	31111091	012_2_11597	31111091	0		012_1_11547	31112092	0
	004_2_10685	30040001	0		012_3_11651	31111091	0		012_2_11597	31112092	0
	004_3_10722	30040001	0		012_4_25381	31111091	1		012_3_11651	31112092	0
	004_4_25109	30040001	1		012_5_32832	31111091	1		012_4_25381	31112092	1
31100003	003_0_10557	31100003	0	31111097	012_0_11498	31111097	0		012_5_32832	31112092	1
	003_1_10576	31100003	0		012_1_11547	31111097	0		012_6_64016	31112092	1
	003_2_10596	31100003	0		012_2_11597	31111097	0	31112150	004_0_10617	31112150	0
	003_3_25078	31100003	1		012_3_11651	31111097	0		004_1_10650	31112150	0
	003_4_27606	31100003	1		012_4_25381	31111097	1		004_2_10685	31112150	0



SPARE PARTS INSTANCE INDEX

Code	Parts Table	Pos.	Q.ty	Code	Parts Table	Pos.	Q.ty	Code	Parts Table	Pos.	Q.ty
31112150	004_3_10722	31112150	0	31112217	10A_2_12281	31112217	0	31211040	012_3_11651	31211040	0
	004_4_25109	31112150	1		10A_3_12322	31112217	0		012_4_25381	31211040	1
	010_0_11134	31112150	0		10A_4_63871	31112217	1		012_5_32832	31211040	1
	10A_4_63871	31112150	1	31112293	10A_1_12244	31112293	0	31211060	002_0_10478	31211060	0
31112152	010_0_11134	31112152	0		10A_2_12281	31112293	0		002_1_10500	31211060	0
	010_1_11182	31112152	0		10A_3_12322	31112293	0	31211080	003_0_10557	31211080	0
	010_2_11218	31112152	0		10A_4_63871	31112293	1		003_1_10576	31211080	0
31112153	012_0_11498	31112153	0	31112294	10A_0_12219	31112294	0		003_2_10596	31211080	0
	012_1_11547	31112153	0		10A_1_12244	31112294	0		003_3_25078	31211080	1
	012_2_11597	31112153	0		10A_2_12281	31112294	0		003_4_27606	31211080	1
	012_3_11651	31112153	0		10A_3_12322	31112294	0		003_5_33490	31211080	1
	012_4_25381	31112153	1		10A_4_63871	31112294	1		010_0_11134	31211080	0
	012_5_32832	31112153	1	31121005	01A_0_12068	31121005	0		012_0_11498	31211080	0
	012_6_64016	31112153	1		01A_1_12095	31121005	0		012_1_11547	31211080	0
	10A_0_12219	31112153	0		01A_2_12123	31121005	0		012_2_11597	31211080	0
	10A_1_12244	31112153	0		01A_3_12154	31121005	0		012_3_11651	31211080	0
	10A_2_12281	31112153	0		01A_4_24894	31121005	0		012_4_25381	31211080	1
	10A_3_12322	31112153	0	31132562	004_1_10650	31132562	0		012_5_32832	31211080	1
	10A_4_63871	31112153	1		004_2_10685	31132562	0		012_6_64016	31211080	1
31112154	01A_2_12123	31112154	0		004_3_10722	31132562	0		01A_0_12068	31211080	0
	01A_3_12154	31112154	0		004_4_25109	31132562	1		01A_1_12095	31211080	0
	01A_4_24894	31112154	0	31152103	004_0_10617	31152103	0		01A_2_12123	31211080	0
	10A_2_12281	31112154	0		004_1_10650	31152103	0		01A_3_12154	31211080	0
31112155	01A_0_12068	31112155	0		004_2_10685	31152103	0		01A_4_24894	31211080	0
	01A_1_12095	31112155	0		004_3_10722	31152103	0		10A_0_12219	31211080	0
31112156	01A_2_12123	31112156	0		004_4_25109	31152103	1		10A_1_12244	31211080	0
	01A_3_12154	31112156	0	31161043	002_0_10478	31161043	0		10A_4_63871	31211080	1
	01A_4_24894	31112156	0		002_1_10500	31161043	0	31211100	004_0_10617	31211100	0
31112210	004_3_10722	31112210	0	31201212	010_0_11134	31201212	0		004_1_10650	31211100	0
	004_4_25109	31112210	1	31211040	002_0_10478	31211040	0		004_2_10685	31211100	0
31112211	005_0_10769	31112211	0		002_1_10500	31211040	0		004_3_10722	31211100	0
	005_1_10807	31112211	0		012_0_11498	31211040	0		007_0_10996	31211100	0
	005_2_10845	31112211	0		012_1_11547	31211040	0		007_1_11010	31211100	0
31112217	10A_1_12244	31112217	0		012_2_11597	31211040	0		015_0_11945	31211100	0

SPARE PARTS INSTANCE INDEX

Code	Parts Table	Pos.	Q.ty	Code	Parts Table	Pos.	Q.ty	Code	Parts Table	Pos.	Q.ty
31211100	015_1_11971	31211100	0	31241080	012_6_64016	31241080	1	31241126	10A_4_63871	31241126	1
	015_2_11997	31211100	0		01A_0_12068	31241080	0	31312082	004_0_10617	31312082	0
	015_3_64117	31211100	1		01A_1_12095	31241080	0		004_1_10650	31312082	0
31215100	010_0_11134	31215100	0		01A_2_12123	31241080	0		004_2_10685	31312082	0
31221121	004_0_10617	31221121	0		01A_3_12154	31241080	0		004_3_10722	31312082	0
	004_1_10650	31221121	0		01A_4_24894	31241080	0		004_4_25109	31312082	1
	004_2_10685	31221121	0		10A_0_12219	31241080	0		010_0_11134	31312082	0
	004_3_10722	31221121	0		10A_1_12244	31241080	0		010_1_11182	31312082	0
	004_4_25109	31221121	1		10A_2_12281	31241080	0		010_2_11218	31312082	0
31241060	002_0_10478	31241060	0		10A_3_12322	31241080	0	31312083	003_0_10557	31312083	0
	002_1_10500	31241060	0		10A_4_63871	31241080	1		003_1_10576	31312083	0
	012_0_11498	31241060	0	31241085	004_0_10617	31241085	0		003_2_10596	31312083	0
	012_1_11547	31241060	0		004_1_10650	31241085	0		003_3_25078	31312083	1
	012_2_11597	31241060	0		004_2_10685	31241085	0		003_4_27606	31312083	1
	012_3_11651	31241060	0		004_3_10722	31241085	0		003_5_33490	31312083	1
	012_4_25381	31241060	1		004_4_25109	31241085	1	31312084	004_0_10617	31312084	0
	012_5_32832	31241060	1		010_1_11182	31241085	0		004_1_10650	31312084	0
	012_6_64016	31241060	1		010_2_11218	31241085	0		004_2_10685	31312084	0
31241080	003_3_25078	31241080	1	31241100	010_1_11182	31241100	0		004_3_10722	31312084	0
	003_4_27606	31241080	1		010_2_11218	31241100	0		004_4_25109	31312084	1
	003_5_33490	31241080	1		10A_0_12219	31241100	0	31312086	004_0_10617	31312086	0
	004_0_10617	31241080	0		10A_1_12244	31241100	0		004_1_10650	31312086	0
	004_1_10650	31241080	0		10A_2_12281	31241100	0		004_2_10685	31312086	0
	004_2_10685	31241080	0		10A_3_12322	31241100	0		004_3_10722	31312086	0
	004_3_10722	31241080	0		10A_4_63871	31241100	1		004_4_25109	31312086	1
	004_4_25109	31241080	1	31241120	007_0_10996	31241120	0	31312088	003_0_10557	31312088	0
	010_0_11134	31241080	0		007_1_11010	31241120	0		003_1_10576	31312088	0
	010_1_11182	31241080	0		10A_2_12281	31241120	0		003_2_10596	31312088	0
	010_2_11218	31241080	0		10A_3_12322	31241120	0		003_3_25078	31312088	1
	012_1_11547	31241080	0		10A_4_63871	31241120	1		003_4_27606	31312088	1
	012_2_11597	31241080	0	31241126	10A_0_12219	31241126	0		003_5_33490	31312088	1
	012_3_11651	31241080	0		10A_1_12244	31241126	0	31312094	004_0_10617	31312094	0
	012_4_25381	31241080	1		10A_2_12281	31241126	0		004_1_10650	31312094	0
	012_5_32832	31241080	1		10A_3_12322	31241126	0		004_2_10685	31312094	0

SPARE PARTS INSTANCE INDEX

Code	Parts Table	Pos.	Q.ty	Code	Parts Table	Pos.	Q.ty	Code	Parts Table	Pos.	Q.ty
31312094	004_3_10722	31312094	0	31411064	012_6_64016	31411064	1	31421083	010_2_11218	31421083	0
	004_4_25109	31312094	1		10A_0_12219	31411064	0		10A_4_63871	31421083	1
31312101	004_0_10617	31312101	0		10A_1_12244	31411064	0	31421100	10A_0_12219	31421100	0
	004_1_10650	31312101	0		10A_2_12281	31411064	0		10A_1_12244	31421100	0
	004_2_10685	31312101	0		10A_3_12322	31411064	0		10A_2_12281	31421100	0
	004_3_10722	31312101	0	31411084	003_3_25078	31411084	1		10A_3_12322	31421100	0
31312102	007_0_10996	31312102	0		012_0_11498	31411084	0		10A_4_63871	31421100	1
	007_1_11010	31312102	0		012_1_11547	31411084	0	31421101	004_3_10722	31421101	0
	015_0_11945	31312102	0		012_2_11597	31411084	0		004_4_25109	31421101	1
	015_1_11971	31312102	0		012_3_11651	31411084	0		005_0_10769	31421101	0
31312103	015_2_11997	31312103	0		012_4_25381	31411084	1		005_1_10807	31421101	0
	015_3_64117	31312103	1		012_5_32832	31411084	1		005_2_10845	31421101	0
31312124	004_3_10722	31312124	0		012_6_64016	31411084	1	31421130	007_0_10996	31421130	0
	004_4_25109	31312124	1		01A_0_12068	31411084	0		007_1_11010	31421130	0
31312125	004_0_10617	31312125	0		01A_1_12095	31411084	0	31421132	004_3_10722	31421132	0
	004_1_10650	31312125	0		01A_2_12123	31411084	0		004_4_25109	31421132	1
	004_2_10685	31312125	0		01A_3_12154	31411084	0	31422064	004_0_10617	31422064	0
	004_3_10722	31312125	0		01A_4_24894	31411084	0		004_1_10650	31422064	0
	004_4_25109	31312125	1	31411104	010_0_11134	31411104	0		004_2_10685	31422064	0
31411043	012_0_11498	31411043	0		010_1_11182	31411104	0		004_3_10722	31422064	0
	012_1_11547	31411043	0		010_2_11218	31411104	0		004_4_25109	31422064	1
	012_2_11597	31411043	0		01A_0_12068	31411104	0	31423043	002_0_10478	31423043	0
	012_3_11651	31411043	0		01A_1_12095	31411104	0		002_1_10500	31423043	0
	012_4_25381	31411043	1		01A_2_12123	31411104	0		012_0_11498	31423043	0
	012_5_32832	31411043	1		01A_3_12154	31411104	0		012_1_11547	31423043	0
	10A_4_63871	31411043	1		01A_4_24894	31411104	0		012_2_11597	31423043	0
31411064	002_0_10478	31411064	0	31414130	010_2_11218	31414130	0		012_3_11651	31423043	0
	002_1_10500	31411064	0	31421083	004_0_10617	31421083	0		012_4_25381	31423043	1
	012_0_11498	31411064	0		004_1_10650	31421083	0		012_5_32832	31423043	1
	012_1_11547	31411064	0		004_2_10685	31421083	0	31423084	003_0_10557	31423084	0
	012_2_11597	31411064	0		004_3_10722	31421083	0		003_1_10576	31423084	0
	012_3_11651	31411064	0		004_4_25109	31421083	1		003_2_10596	31423084	0
	012_4_25381	31411064	1		010_0_11134	31421083	0		003_3_25078	31423084	1
	012_5_32832	31411064	1		010_1_11182	31421083	0		003_4_27606	31423084	1

SPARE PARTS INSTANCE INDEX

Code	Parts Table	Pos.	Q.ty	Code	Parts Table	Pos.	Q.ty	Code	Parts Table	Pos.	Q.ty
31423084	003_5_33490	31423084	1	31423105	007_1_11010	31423105	0	34211041	10A_3_12322	34211041	0
	004_0_10617	31423084	0		015_0_11945	31423105	0		10A_4_63871	34211041	1
	004_1_10650	31423084	0		015_1_11971	31423105	0	34211042	005_0_10769	34211042	0
	004_2_10685	31423084	0		015_2_11997	31423105	0		005_1_10807	34211042	0
	004_3_10722	31423084	0		015_3_64117	31423105	1		005_2_10845	34211042	0
	004_4_25109	31423084	1		10A_1_12244	31423105	0	34213020	010_0_11134	34213020	0
	010_0_11134	31423084	0		10A_2_12281	31423105	0		010_1_11182	34213020	0
	010_1_11182	31423084	0		10A_3_12322	31423105	0		010_2_11218	34213020	0
	010_2_11218	31423084	0		10A_4_63871	31423105	1		012_0_11498	34213020	0
	012_0_11498	31423084	0	31423130	004_0_10617	31423130	0		012_1_11547	34213020	0
	012_1_11547	31423084	0		004_1_10650	31423130	0		012_2_11597	34213020	0
	012_2_11597	31423084	0		004_2_10685	31423130	0		012_3_11651	34213020	0
	012_3_11651	31423084	0		10A_2_12281	31423130	0		012_4_25381	34213020	1
	012_4_25381	31423084	1		10A_3_12322	31423130	0		012_5_32832	34213020	1
	012_5_32832	31423084	1		10A_4_63871	31423130	1		012_6_64016	34213020	1
	012_6_64016	31423084	1	31510100	01A_0_12068	31510100	0	34213022	010_0_11134	34213022	0
	01A_0_12068	31423084	0		01A_1_12095	31510100	0		010_1_11182	34213022	0
	01A_1_12095	31423084	0		01A_2_12123	31510100	0		010_2_11218	34213022	0
	01A_2_12123	31423084	0		01A_3_12154	31510100	0	34213024	010_0_11134	34213024	0
	01A_3_12154	31423084	0		01A_4_24894	31510100	0		010_1_11182	34213024	0
	01A_4_24894	31423084	0	34110028	010_0_11134	34110028	0		010_2_11218	34213024	0
	10A_0_12219	31423084	0		010_1_11182	34110028	0	34213060	005_0_10769	34213060	0
	10A_1_12244	31423084	0		010_2_11218	34110028	0		005_1_10807	34213060	0
	10A_2_12281	31423084	0	34110030	01A_0_12068	34110030	0		005_2_10845	34213060	0
	10A_3_12322	31423084	0		01A_1_12095	34110030	0	34213061	005_0_10769	34213061	0
	10A_4_63871	31423084	1		01A_2_12123	34110030	0		005_1_10807	34213061	0
31423105	003_3_25078	31423105	1		01A_3_12154	34110030	0		005_2_10845	34213061	0
	003_4_27606	31423105	1		01A_4_24894	34110030	0	34221070	10A_1_12244	34221070	0
	003_5_33490	31423105	1	34211028	10A_1_12244	34211028	0		10A_2_12281	34221070	0
	004_0_10617	31423105	0		10A_2_12281	34211028	0		10A_3_12322	34221070	0
	004_1_10650	31423105	0		10A_3_12322	34211028	0		10A_4_63871	34221070	1
	004_2_10685	31423105	0		10A_4_63871	34211028	1	34311060	007_0_10996	34311060	0
	004_3_10722	31423105	0	34211041	10A_1_12244	34211041	0		007_1_11010	34311060	0
	007_0_10996	31423105	0		10A_2_12281	34211041	0	35111052	005_0_10769	35111052	0



SPARE PARTS INSTANCE INDEX

Code	Parts Table	Pos.	Q.ty	Code	Parts Table	Pos.	Q.ty	Code	Parts Table	Pos.	Q.ty
35111052	005_1_10807	35111052	0	37112231	003_0_10557	37112231	0	39114008	015_1_11971	39114008	0
	005_2_10845	35111052	0		003_1_10576	37112231	0		015_2_11997	39114008	0
	007_0_10996	35111052	0		003_2_10596	37112231	0		015_3_64117	39114008	1
	007_1_11010	35111052	0		003_3_25078	37112231	1	39114010	015_0_11945	39114010	0
35111055	005_0_10769	35111055	0		003_4_27606	37112231	1		015_1_11971	39114010	0
	005_1_10807	35111055	0	37112233	003_3_25078	37112233	1		015_2_11997	39114010	0
	005_2_10845	35111055	0		003_4_27606	37112233	1		015_3_64117	39114010	1
35121014	004_4_25109	35121014	1	37320120	005_0_10769	37320120	0	39115010	015_0_11945	39115010	0
35121031	005_0_10769	35121031	0		005_1_10807	37320120	0		015_1_11971	39115010	0
	005_1_10807	35121031	0		005_2_10845	37320120	0		015_2_11997	39115010	0
	005_2_10845	35121031	0	37910832	005_0_10769	37910832	0		015_3_64117	39115010	1
35211120	005_0_10769	35211120	0		005_1_10807	37910832	0	39115012	015_0_11945	39115012	0
	005_1_10807	35211120	0		005_2_10845	37910832	0		015_1_11971	39115012	0
	005_2_10845	35211120	0	37911532	010_0_11134	37911532	0		015_2_11997	39115012	0
37111150	005_0_10769	37111150	0		010_1_11182	37911532	0		015_3_64117	39115012	1
	005_1_10807	37111150	0		010_2_11218	37911532	0	39116018	015_0_11945	39116018	0
	005_2_10845	37111150	0	38111191	010_2_11218	38111191	0		015_1_11971	39116018	0
37111152	005_0_10769	37111152	0	38211400	010_0_11134	38211400	0		015_2_11997	39116018	0
	005_1_10807	37111152	0		010_1_11182	38211400	0		015_3_64117	39116018	1
	005_2_10845	37111152	0		010_2_11218	38211400	0	39414008	015_0_11945	39414008	0
37111250	005_0_10769	37111250	0	38211500	004_0_10617	38211500	0		015_1_11971	39414008	0
	005_1_10807	37111250	0		004_1_10650	38211500	0		015_2_11997	39414008	0
	005_2_10845	37111250	0		004_2_10685	38211500	0		015_3_64117	39414008	1
	007_0_10996	37111250	0		004_3_10722	38211500	0	39414010	015_0_11945	39414010	0
	007_1_11010	37111250	0		004_4_25109	38211500	1		015_1_11971	39414010	0
37112173	003_0_10557	37112173	0		005_1_10807	38211500	0		015_2_11997	39414010	0
	003_1_10576	37112173	0		005_2_10845	38211500	0		015_3_64117	39414010	1
	003_2_10596	37112173	0	38211501	005_0_10769	38211501	0	39415010	015_0_11945	39415010	0
	003_3_25078	37112173	1	38212501	007_0_10996	38212501	0		015_1_11971	39415010	0
	003_4_27606	37112173	1		007_1_11010	38212501	0		015_2_11997	39415010	0
	003_5_33490	37112173	1	38213800	005_0_10769	38213800	0		015_3_64117	39415010	1
37112229	005_0_10769	37112229	0		005_1_10807	38213800	0	39415012	015_0_11945	39415012	0
	005_1_10807	37112229	0		005_2_10845	38213800	0		015_1_11971	39415012	0
	005_2_10845	37112229	0	39114008	015_0_11945	39114008	0		015_2_11997	39415012	0

SPARE PARTS INSTANCE INDEX

Code	Parts Table	Pos.	Q.ty	Code	Parts Table	Pos.	Q.ty	Code	Parts Table	Pos.	Q.ty
39415012	015_3_64117	39415012	1	52456354	005_0_10769	52456354	0	53152408	004_3_10722	53152408	0
39416018	015_0_11945	39416018	0		005_1_10807	52456354	0		004_4_25109	53152408	1
	015_1_11971	39416018	0		005_2_10845	52456354	0	53152409	004_3_10722	53152409	0
	015_2_11997	39416018	0	52456358	005_0_10769	52456358	0		004_4_25109	53152409	1
	015_3_64117	39416018	1	52456361	005_1_10807	52456361	0	53152410	004_3_10722	53152410	0
50947833	003_0_10557	50947833	0		005_2_10845	52456361	0		004_4_25109	53152410	1
50956262	003_1_10576	50956262	0	52456362	005_0_10769	52456362	0	53152412	004_3_10722	53152412	0
	003_2_10596	50956262	0		005_1_10807	52456362	0		004_4_25109	53152412	1
	003_3_25078	50956262	1		005_2_10845	52456362	0	53156150	003_3_25078	53156150	1
	003_4_27606	50956262	1	52456370	005_0_10769	52456370	0		003_4_27606	53156150	1
	003_5_33490	50956262	1		005_1_10807	52456370	0		003_5_33490	53156150	1
52156917	10A_0_12219	52156917	0		005_2_10845	52456370	0	53156325	004_0_10617	53156325	0
	10A_1_12244	52156917	0	52456389	005_0_10769	52456389	0		004_1_10650	53156325	0
	10A_2_12281	52156917	0		005_1_10807	52456389	0		004_2_10685	53156325	0
	10A_3_12322	52156917	0		005_2_10845	52456389	0		004_3_10722	53156325	0
	10A_4_63871	52156917	1	52456390	005_0_10769	52456390	0	53156326	004_0_10617	53156326	0
52357250	010_0_11134	52357250	0		005_1_10807	52456390	0		004_1_10650	53156326	0
	010_1_11182	52357250	0		005_2_10845	52456390	0		004_2_10685	53156326	0
	010_2_11218	52357250	0	53143128	004_0_10617	53143128	0		004_3_10722	53156326	0
52447896	003_0_10557	52447896	0		004_1_10650	53143128	0	53156332	004_0_10617	53156332	0
	003_1_10576	52447896	0		004_2_10685	53143128	0		004_1_10650	53156332	0
	003_2_10596	52447896	0		004_3_10722	53143128	0		004_2_10685	53156332	0
	003_3_25078	52447896	1	53143712	015_0_11945	53143712	0		004_3_10722	53156332	0
	003_4_27606	52447896	1		015_1_11971	53143712	0	53156342	004_1_10650	53156342	0
	003_5_33490	52447896	1		015_2_11997	53143712	0		004_2_10685	53156342	0
52456335	005_0_10769	52456335	0		015_3_64117	53143712	1		004_3_10722	53156342	0
	005_1_10807	52456335	0	53143875	004_0_10617	53143875	0	53156346	004_2_10685	53156346	0
	005_2_10845	52456335	0		004_1_10650	53143875	0		004_3_10722	53156346	0
52456339	005_0_10769	52456339	0		004_2_10685	53143875	0		004_4_25109	53156346	1
	005_1_10807	52456339	0		004_3_10722	53143875	0	53247468	003_0_10557	53247468	0
	005_2_10845	52456339	0	53152401	004_3_10722	53152401	0		003_1_10576	53247468	0
52456344	005_0_10769	52456344	0		004_4_25109	53152401	1		003_2_10596	53247468	0
	005_1_10807	52456344	0	53152402	004_3_10722	53152402	0		003_3_25078	53247468	1
52456349	005_2_10845	52456349	0		004_4_25109	53152402	1		003_4_27606	53247468	1

SPARE PARTS INSTANCE INDEX

Code	Parts Table	Pos.	Q.ty	Code	Parts Table	Pos.	Q.ty	Code	Parts Table	Pos.	Q.ty
53247488	003_5_33490	53247488	1	55243340	10A_0_12219	55243340	0	55248379	010_1_11182	55248379	0
54143090	007_0_10996	54143090	0		10A_1_12244	55243340	0		010_2_11218	55248379	0
	007_1_11010	54143090	0		10A_2_12281	55243340	0	55249668	10A_0_12219	55249668	0
55102678	004_0_10617	55102678	0		10A_3_12322	55243340	0		10A_1_12244	55249668	0
	004_1_10650	55102678	0		10A_4_63871	55243340	1		10A_2_12281	55249668	0
	004_2_10685	55102678	0	55248038	012_0_11498	55248038	0		10A_3_12322	55249668	0
	004_3_10722	55102678	0		012_1_11547	55248038	0		10A_4_63871	55249668	1
	004_4_25109	55102678	1		012_2_11597	55248038	0	55251686	10A_1_12244	55251686	0
55102714	10A_0_12219	55102714	0		012_3_11651	55248038	0		10A_2_12281	55251686	0
	10A_1_12244	55102714	0		012_4_25381	55248038	1		10A_3_12322	55251686	0
	10A_2_12281	55102714	0		012_5_32832	55248038	1		10A_4_63871	55251686	1
	10A_3_12322	55102714	0		012_6_64016	55248038	1	55251688	10A_1_12244	55251688	0
	10A_4_63871	55102714	1	55248041	012_0_11498	55248041	0		10A_2_12281	55251688	0
55142076	010_0_11134	55142076	0		012_1_11547	55248041	0		10A_3_12322	55251688	0
	010_1_11182	55142076	0		012_2_11597	55248041	0		10A_4_63871	55251688	1
	010_2_11218	55142076	0		012_3_11651	55248041	0	55252318	01A_0_12068	55252318	0
55142109	01A_0_12068	55142109	0		012_4_25381	55248041	1		01A_1_12095	55252318	0
	01A_1_12095	55142109	0		012_5_32832	55248041	1		01A_2_12123	55252318	0
	01A_2_12123	55142109	0		012_6_64016	55248041	1		01A_3_12154	55252318	0
	01A_3_12154	55142109	0	55248283	012_0_11498	55248283	0		01A_4_24894	55252318	0
	01A_4_24894	55142109	0		012_1_11547	55248283	0	55257249	010_0_11134	55257249	0
55147842	003_0_10557	55147842	0		012_2_11597	55248283	0		010_1_11182	55257249	0
	003_1_10576	55147842	0		012_3_11651	55248283	0		010_2_11218	55257249	0
	003_2_10596	55147842	0		012_4_25381	55248283	1	55257255	010_0_11134	55257255	0
	003_3_25078	55147842	1		012_5_32832	55248283	1	55257313	010_1_11182	55257313	0
	003_4_27606	55147842	1		012_6_64016	55248283	1		010_2_11218	55257313	0
	003_5_33490	55147842	1	55248284	012_0_11498	55248284	0	55257321	010_1_11182	55257321	0
55157609	003_1_10576	55157609	0		012_1_11547	55248284	0		010_2_11218	55257321	0
	003_2_10596	55157609	0		012_2_11597	55248284	0	56119937	002_0_10478	56119937	0
	003_3_25078	55157609	1		012_3_11651	55248284	0		002_1_10500	56119937	0
	003_4_27606	55157609	1		012_4_25381	55248284	1	56137370	002_0_10478	56137370	0
	003_5_33490	55157609	1		012_5_32832	55248284	1		002_1_10500	56137370	0
55220363	004_4_25109	55220363	1		012_6_64016	55248284	1	56142314	010_0_11134	56142314	0
55243340	012_0_11498	55243340	0	55248379	010_0_11134	55248379	0	56143059	007_0_10996	56143059	0

SPARE PARTS INSTANCE INDEX

Code	Parts Table	Pos.	Q.ty	Code	Parts Table	Pos.	Q.ty	Code	Parts Table	Pos.	Q.ty
56143059	007_1_11010	56143059	0	56148037	012_2_11597	56148037	0	56152403	004_3_10722	56152403	0
56143878	004_0_10617	56143878	0		012_3_11651	56148037	0		004_4_25109	56152403	1
	004_1_10650	56143878	0		012_4_25381	56148037	1	56156261	004_4_25109	56156261	1
56147520	004_0_10617	56147520	0		012_5_32832	56148037	1	56156276	003_4_27606	56156276	1
	004_1_10650	56147520	0		012_6_64016	56148037	1		003_5_33490	56156276	1
	004_2_10685	56147520	0	56148285	012_0_11498	56148285	0	56156281	003_4_27606	56156281	1
	004_3_10722	56147520	0		012_1_11547	56148285	0		003_5_33490	56156281	1
56147648	010_0_11134	56147648	0		012_2_11597	56148285	0	56156284	003_5_33490	56156284	1
56147655	012_0_11498	56147655	0		012_3_11651	56148285	0	56156285	003_5_33490	56156285	1
	012_1_11547	56147655	0		012_4_25381	56148285	1	56156940	10A_0_12219	56156940	0
	012_2_11597	56147655	0		012_5_32832	56148285	1		10A_1_12244	56156940	0
	012_3_11651	56147655	0		012_6_64016	56148285	1		10A_2_12281	56156940	0
	012_4_25381	56147655	1	56148286	012_0_11498	56148286	0		10A_3_12322	56156940	0
	012_5_32832	56147655	1		012_3_11651	56148286	0		10A_4_63871	56156940	1
	012_6_64016	56147655	1		012_4_25381	56148286	1	56156948	10A_3_12322	56156948	0
56147711	012_0_11498	56147711	0		012_5_32832	56148286	1		10A_4_63871	56156948	1
	012_1_11547	56147711	0		012_6_64016	56148286	1	56157236	010_1_11182	56157236	0
	012_2_11597	56147711	0	56148287	012_0_11498	56148287	0		010_2_11218	56157236	0
	012_3_11651	56147711	0		012_1_11547	56148287	0	56157245	10A_0_12219	56157245	0
	012_4_25381	56147711	1		012_2_11597	56148287	0		10A_1_12244	56157245	0
	012_5_32832	56147711	1		012_3_11651	56148287	0	56157248	010_1_11182	56157248	0
56147845	003_0_10557	56147845	0		012_4_25381	56148287	1		010_2_11218	56157248	0
	003_1_10576	56147845	0		012_5_32832	56148287	1	56157257	010_0_11134	56157257	0
	003_2_10596	56147845	0		012_6_64016	56148287	1		010_1_11182	56157257	0
	003_3_25078	56147845	1	56149590	002_0_10478	56149590	0		010_2_11218	56157257	0
	003_4_27606	56147845	1		002_1_10500	56149590	0	56157260	010_0_11134	56157260	0
	003_5_33490	56147845	1	56150361	012_0_11498	56150361	0	56157271	010_0_11134	56157271	0
56147923	004_0_10617	56147923	0		012_1_11547	56150361	0	56157274	010_0_11134	56157274	0
	004_1_10650	56147923	0		012_2_11597	56150361	0		010_1_11182	56157274	0
	004_2_10685	56147923	0		012_3_11651	56150361	0		010_2_11218	56157274	0
	004_3_10722	56147923	0		012_4_25381	56150361	1	56157311	010_1_11182	56157311	0
	004_4_25109	56147923	1		012_5_32832	56150361	1		010_2_11218	56157311	0
56148037	012_0_11498	56148037	0		012_6_64016	56150361	1	56157312	010_1_11182	56157312	0
	012_1_11547	56148037	0	56152315	010_0_11134	56152315	0		010_2_11218	56157312	0

SPARE PARTS INSTANCE INDEX

Code	Parts Table	Pos.	Q.ty	Code	Parts Table	Pos.	Q.ty	Code	Parts Table	Pos.	Q.ty
56157324	010_1_11182	56157324	0	56343058	007_0_10996	56343058	0	56456347	005_0_10769	56456347	0
	010_2_11218	56157324	0		007_1_11010	56343058	0		005_1_10807	56456347	0
56157332	012_1_11547	56157332	0	56347484	003_3_25078	56347484	1		005_2_10845	56456347	0
	012_2_11597	56157332	0		003_4_27606	56347484	1	56456351	005_0_10769	56456351	0
	012_3_11651	56157332	0	56347700	10A_0_12219	56347700	0		005_1_10807	56456351	0
	012_4_25381	56157332	1		10A_1_12244	56347700	0		005_2_10845	56456351	0
	012_5_32832	56157332	1	56349782	003_3_25078	56349782	1	56456475	005_0_10769	56456475	0
	012_6_64016	56157332	1	56351685	10A_1_12244	56351685	0		005_1_10807	56456475	0
56157411	10A_4_63871	56157411	1		10A_2_12281	56351685	0		005_2_10845	56456475	0
56157412	10A_4_63871	56157412	1		10A_3_12322	56351685	0	58002429	012_0_11498	58002429	0
56157532	01A_4_24894	56157532	1		10A_4_63871	56351685	1		012_1_11547	58002429	0
56157539	01A_0_12068	56157539	0	56356165	003_2_10596	56356165	0		012_2_11597	58002429	0
	01A_1_12095	56157539	0		003_3_25078	56356165	1		012_3_11651	58002429	0
	01A_2_12123	56157539	0	56356251	003_0_10557	56356251	0		012_4_25381	58002429	1
	01A_3_12154	56157539	0		003_1_10576	56356251	0		012_5_32832	58002429	1
	01A_4_24894	56157539	0		003_2_10596	56356251	0		012_6_64016	58002429	1
56157555	01A_0_12068	56157555	0		003_3_25078	56356251	1	58002538	012_0_11498	58002538	0
	01A_1_12095	56157555	0		003_4_27606	56356251	1		012_1_11547	58002538	0
	01A_2_12123	56157555	0	56356328	005_0_10769	56356328	0		012_2_11597	58002538	0
	01A_3_12154	56157555	0		005_1_10807	56356328	0		012_3_11651	58002538	0
	01A_4_24894	56157555	0		005_2_10845	56356328	0		012_4_25381	58002538	1
56157590	01A_0_12068	56157590	0	56356329	005_0_10769	56356329	0		012_5_32832	58002538	1
	01A_1_12095	56157590	0		005_1_10807	56356329	0		012_6_64016	58002538	1
	01A_2_12123	56157590	0		005_2_10845	56356329	0	58042067	012_0_11498	58042067	0
	01A_3_12154	56157590	0	56356330	005_0_10769	56356330	0		012_1_11547	58042067	0
	01A_4_24894	56157590	0		005_1_10807	56356330	0		012_2_11597	58042067	0
56157606	004_2_10685	56157606	0		005_2_10845	56356330	0		012_3_11651	58042067	0
	004_3_10722	56157606	0	56356331	005_0_10769	56356331	0		012_4_25381	58042067	1
	004_4_25109	56157606	1		005_1_10807	56356331	0		012_5_32832	58042067	1
56157607	004_2_10685	56157607	0		005_2_10845	56356331	0	58042111	01A_0_12068	58042111	0
	004_3_10722	56157607	0	56356348	005_2_10845	56356348	0		01A_1_12095	58042111	0
	004_4_25109	56157607	1	56356924	10A_2_12281	56356924	0		01A_2_12123	58042111	0
56157856	010_0_11134	56157856	0		10A_3_12322	56356924	0		01A_3_12154	58042111	0
56252136	010_0_11134	56252136	0		10A_4_63871	56356924	1		01A_4_24894	58042111	0



SPARE PARTS INSTANCE INDEX

Code	Parts Table	Pos.	Q.ty	Code	Parts Table	Pos.	Q.ty	Code	Parts Table	Pos.	Q.ty
58042167	012_0_11498	58042167	0	58043032	002_0_10478	58043032	0	58046912	016_2_25498	58046912	1
	012_1_11547	58042167	0		002_1_10500	58043032	0		016_3_32939	58046912	1
	012_2_11597	58042167	0	58043034	002_0_10478	58043034	0	58046913	016_0_12023	58046913	0
	012_3_11651	58042167	0		002_1_10500	58043034	0		016_1_12046	58046913	0
	012_4_25381	58042167	1	58043036	002_0_10478	58043036	0		016_2_25498	58046913	1
	012_5_32832	58042167	1		002_1_10500	58043036	0	58047568	012_0_11498	58047568	0
	012_6_64016	58042167	1	58043053	004_0_10617	58043053	0		012_1_11547	58047568	0
	10A_2_12281	58042167	0		004_1_10650	58043053	0		012_2_11597	58047568	0
	10A_3_12322	58042167	0		004_2_10685	58043053	0	58047712	012_0_11498	58047712	0
	10A_4_63871	58042167	1		004_3_10722	58043053	0		012_1_11547	58047712	0
58042200	012_1_11547	58042200	0		004_4_25109	58043053	1		012_2_11597	58047712	0
	012_2_11597	58042200	0	58043086	005_0_10769	58043086	0		012_3_11651	58047712	0
	012_3_11651	58042200	0		005_1_10807	58043086	0		012_4_25381	58047712	1
	012_4_25381	58042200	1		005_2_10845	58043086	0		012_5_32832	58047712	1
	012_5_32832	58042200	1	58043117	004_0_10617	58043117	0		10A_4_63871	58047712	1
	012_6_64016	58042200	1		004_1_10650	58043117	0	58047729	016_2_25498	58047729	1
58042202	012_0_11498	58042202	0		004_2_10685	58043117	0		016_3_32939	58047729	1
	012_1_11547	58042202	0		004_3_10722	58043117	0	58048000	012_0_11498	58048000	0
	012_2_11597	58042202	0		004_4_25109	58043117	1		012_1_11547	58048000	0
	012_3_11651	58042202	0	58043176	010_0_11134	58043176	0		012_2_11597	58048000	0
	012_4_25381	58042202	1		010_1_11182	58043176	0		012_3_11651	58048000	0
	012_5_32832	58042202	1		010_2_11218	58043176	0		012_4_25381	58048000	1
	012_6_64016	58042202	1	58043219	012_0_11498	58043219	0		012_5_32832	58048000	1
58042219	10A_1_12244	58042219	0		012_6_64016	58043219	1		012_6_64016	58048000	1
	10A_2_12281	58042219	0	58043250	015_0_11945	58043250	0	58048002	012_6_64016	58048002	1
	10A_3_12322	58042219	0	58043364	012_0_11498	58043364	0	58048009	012_0_11498	58048009	0
	10A_4_63871	58042219	1	58044804	015_0_11945	58044804	0		012_1_11547	58048009	0
58042486	012_0_11498	58042486	0	58046901	016_0_12023	58046901	0		012_2_11597	58048009	0
	012_2_11597	58042486	0	58046902	016_0_12023	58046902	0		012_3_11651	58048009	0
	012_3_11651	58042486	0	58046903	016_0_12023	58046903	0		10A_4_63871	58048009	1
	012_4_25381	58042486	1	58046909	016_0_12023	58046909	0	58048012	012_2_11597	58048012	0
	012_5_32832	58042486	1	58046910	016_0_12023	58046910	0		012_3_11651	58048012	0
58043031	002_0_10478	58043031	0	58046912	016_0_12023	58046912	0		012_4_25381	58048012	1
	002_1_10500	58043031	0		016_1_12046	58046912	0		012_5_32832	58048012	1



SPARE PARTS INSTANCE INDEX

Code	Parts Table	Pos.	Q.ty	Code	Parts Table	Pos.	Q.ty	Code	Parts Table	Pos.	Q.ty
58048012	012_6_64016	58048012	1	58052027	016_0_12023	58052027	0	58052328	015_2_11997	58052328	0
58048124	002_0_10478	58048124	0		016_1_12046	58052027	0		015_3_64117	58052328	1
	002_1_10500	58048124	0		017_0_25512	58052027	1	58053035	012_6_64016	58053035	1
58048301	012_0_11498	58048301	0	58052028	016_0_12023	58052028	0	58056154	012_2_11597	58056154	0
58048330	015_0_11945	58048330	0		016_1_12046	58052028	0		012_3_11651	58056154	0
58049501	012_6_64016	58049501	1		017_0_25512	58052028	1		012_4_25381	58056154	1
58049505	012_0_11498	58049505	0	58052029	016_0_12023	58052029	0		012_5_32832	58056154	1
	012_1_11547	58049505	0		016_1_12046	58052029	0		012_6_64016	58056154	1
	012_2_11597	58049505	0		017_0_25512	58052029	1	58056155	012_4_25381	58056155	1
	012_3_11651	58049505	0	58052035	016_0_12023	58052035	0		012_5_32832	58056155	1
	012_4_25381	58049505	1		016_1_12046	58052035	0		012_6_64016	58056155	1
	012_5_32832	58049505	1		017_0_25512	58052035	1	58056391	005_0_10769	58056391	0
58050345	012_0_11498	58050345	0	58052036	016_0_12023	58052036	0		005_1_10807	58056391	0
	012_1_11547	58050345	0		016_1_12046	58052036	0		005_2_10845	58056391	0
	012_2_11597	58050345	0		017_0_25512	58052036	1	58056593	012_3_11651	58056593	0
58051670	012_0_11498	58051670	0	58052152	017_0_25512	58052152	1		012_4_25381	58056593	1
	012_1_11547	58051670	0	58052288	015_3_64117	58052288	1		012_5_32832	58056593	1
	012_2_11597	58051670	0	58052317	01A_0_12068	58052317	0		012_6_64016	58056593	1
	012_3_11651	58051670	0		01A_1_12095	58052317	0	58056595	012_6_64016	58056595	1
	012_4_25381	58051670	1		01A_2_12123	58052317	0	58056918	10A_0_12219	58056918	0
	012_5_32832	58051670	1		01A_3_12154	58052317	0		10A_1_12244	58056918	0
	012_6_64016	58051670	1		01A_4_24894	58052317	0		10A_2_12281	58056918	0
58052013	016_0_12023	58052013	0	58052319	01A_0_12068	58052319	0		10A_3_12322	58056918	0
	016_1_12046	58052013	0		01A_1_12095	58052319	0		10A_4_63871	58056918	1
	017_0_25512	58052013	1		01A_2_12123	58052319	0	58056942	10A_0_12219	58056942	0
58052019	016_0_12023	58052019	0		01A_3_12154	58052319	0		10A_1_12244	58056942	0
	016_1_12046	58052019	0		01A_4_24894	58052319	0		10A_2_12281	58056942	0
	017_0_25512	58052019	1	58052326	015_1_11971	58052326	0		10A_3_12322	58056942	0
58052025	016_0_12023	58052025	0		015_2_11997	58052326	0		10A_4_63871	58056942	1
	016_1_12046	58052025	0		015_3_64117	58052326	1	58056991	10A_2_12281	58056991	0
	017_0_25512	58052025	1	58052327	015_1_11971	58052327	0		10A_3_12322	58056991	0
58052026	016_0_12023	58052026	0		015_2_11997	58052327	0		10A_4_63871	58056991	1
	016_1_12046	58052026	0		015_3_64117	58052327	1	58057232	010_0_11134	58057232	0
	017_0_25512	58052026	1	58052328	015_1_11971	58052328	0		010_1_11182	58057232	0

SPARE PARTS INSTANCE INDEX

Code	Parts Table	Pos.	Q.ty	Code	Parts Table	Pos.	Q.ty	Code	Parts Table	Pos.	Q.ty
58057232	010_2_11218	58057232	0	58057288	012_4_25381	58057288	1	58057688	016_0_12023	58057688	0
58057263	012_0_11498	58057263	0		012_5_32832	58057288	1		016_1_12046	58057688	0
	012_1_11547	58057263	0	58057289	012_0_11498	58057289	0		016_2_25498	58057688	1
	012_2_11597	58057263	0	58057297	012_6_64016	58057297	1		016_3_32939	58057688	1
	012_3_11651	58057263	0	58057329	012_1_11547	58057329	0	58057704	016_0_12023	58057704	0
	012_4_25381	58057263	1		012_2_11597	58057329	0		016_1_12046	58057704	0
	012_5_32832	58057263	1		012_3_11651	58057329	0		016_2_25498	58057704	1
	012_6_64016	58057263	1		012_4_25381	58057329	1		016_3_32939	58057704	1
58057266	10A_1_12244	58057266	0		012_5_32832	58057329	1	58057724	016_0_12023	58057724	0
	10A_2_12281	58057266	0		012_6_64016	58057329	1		016_1_12046	58057724	0
	10A_3_12322	58057266	0	58057342	012_2_11597	58057342	0		016_2_25498	58057724	1
	10A_4_63871	58057266	1		012_3_11651	58057342	0		016_3_32939	58057724	1
58057273	010_0_11134	58057273	0		012_4_25381	58057342	1	58057746	016_3_32939	58057746	1
	010_1_11182	58057273	0		012_5_32832	58057342	1	58057748	016_3_32939	58057748	1
	010_2_11218	58057273	0	58057401	012_3_11651	58057401	0	58057767	016_1_12046	58057767	0
58057284	012_1_11547	58057284	0		012_4_25381	58057401	1		016_2_25498	58057767	1
	012_2_11597	58057284	0		012_5_32832	58057401	1		016_3_32939	58057767	1
	012_3_11651	58057284	0	58057413	10A_4_63871	58057413	1	58057768	016_1_12046	58057768	0
	012_4_25381	58057284	1	58057416	012_6_64016	58057416	1		016_2_25498	58057768	1
	012_5_32832	58057284	1	58057417	10A_4_63871	58057417	1		016_3_32939	58057768	1
	012_6_64016	58057284	1	58057419	10A_4_63871	58057419	1	58057770	016_1_12046	58057770	0
58057285	012_1_11547	58057285	0	58057625	016_3_32939	58057625	1		016_2_25498	58057770	1
	012_2_11597	58057285	0	58057676	016_0_12023	58057676	0		016_3_32939	58057770	1
	012_3_11651	58057285	0		016_1_12046	58057676	0	58057772	016_1_12046	58057772	0
	012_4_25381	58057285	1		016_2_25498	58057676	1		016_2_25498	58057772	1
	012_5_32832	58057285	1		016_3_32939	58057676	1		016_3_32939	58057772	1
58057287	012_1_11547	58057287	0	58057677	016_0_12023	58057677	0	58057773	016_3_32939	58057773	1
	012_2_11597	58057287	0		016_1_12046	58057677	0	58057774	016_3_32939	58057774	1
	012_3_11651	58057287	0		016_2_25498	58057677	1	58093089	016_3_32939	58093089	1
	012_4_25381	58057287	1		016_3_32939	58057677	1	58100052	002_0_10478	58100052	0
	012_5_32832	58057287	1	58057678	016_0_12023	58057678	0		002_1_10500	58100052	0
58057288	012_1_11547	58057288	0		016_1_12046	58057678	0	58147704	012_6_64016	58147704	1
	012_2_11597	58057288	0		016_2_25498	58057678	1	58150313	012_0_11498	58150313	0
	012_3_11651	58057288	0		016_3_32939	58057678	1		012_1_11547	58150313	0

SPARE PARTS INSTANCE INDEX

Code	Parts Table	Pos.	Q.ty	Code	Parts Table	Pos.	Q.ty	Code	Parts Table	Pos.	Q.ty
58150313	012_2_11597	58150313	0	59052238	01A_1_12095	59052238	0	59056380	005_0_10769	59056380	0
	012_3_11651	58150313	0		01A_2_12123	59052238	0	59056384	005_1_10807	59056384	0
	012_4_25381	58150313	1		01A_3_12154	59052238	0		005_2_10845	59056384	0
	012_5_32832	58150313	1		01A_4_24894	59052238	0	59056909	10A_2_12281	59056909	0
	012_6_64016	58150313	1	59052239	01A_0_12068	59052239	0	59056911	10A_0_12219	59056911	0
58156156	012_6_64016	58156156	1		01A_1_12095	59052239	0		10A_1_12244	59056911	0
59015425	004_0_10617	59015425	0		01A_2_12123	59052239	0	59056912	10A_0_12219	59056912	0
	004_1_10650	59015425	0		01A_3_12154	59052239	0		10A_1_12244	59056912	0
	004_2_10685	59015425	0		01A_4_24894	59052239	0		10A_2_12281	59056912	0
	004_3_10722	59015425	0		10A_2_12281	59052239	0		10A_3_12322	59056912	0
	004_4_25109	59015425	1	59052244	01A_1_12095	59052244	0		10A_4_63871	59056912	1
59043063	007_0_10996	59043063	0		01A_2_12123	59052244	0	59056920	010_2_11218	59056920	0
	007_1_11010	59043063	0		01A_3_12154	59052244	0	59056935	10A_0_12219	59056935	0
59047708	002_0_10478	59047708	0		01A_4_24894	59052244	0		10A_1_12244	59056935	0
	002_1_10500	59047708	0	59052247	10A_1_12244	59052247	0		10A_2_12281	59056935	0
59047709	012_0_11498	59047709	0		10A_2_12281	59052247	0		10A_3_12322	59056935	0
	012_1_11547	59047709	0		10A_3_12322	59052247	0		10A_4_63871	59056935	1
	012_2_11597	59047709	0		10A_4_63871	59052247	1	59056949	010_1_11182	59056949	0
	012_3_11651	59047709	0	59052252	01A_2_12123	59052252	0	59056952	10A_3_12322	59056952	0
	012_4_25381	59047709	1		01A_3_12154	59052252	0		10A_4_63871	59056952	1
	012_5_32832	59047709	1		01A_4_24894	59052252	0	59057116	012_1_11547	59057116	0
59048042	002_0_10478	59048042	0	59052253	01A_2_12123	59052253	0		012_2_11597	59057116	0
	002_1_10500	59048042	0		01A_3_12154	59052253	0		012_3_11651	59057116	0
59048122	002_0_10478	59048122	0		01A_4_24894	59052253	0		012_4_25381	59057116	1
	002_1_10500	59048122	0	59052322	01A_0_12068	59052322	0	59057231	010_0_11134	59057231	0
59052125	010_0_11134	59052125	0		01A_1_12095	59052322	0	59057251	010_1_11182	59057251	0
59052129	010_0_11134	59052129	0		01A_2_12123	59052322	0		010_2_11218	59057251	0
59052215	012_0_11498	59052215	0		01A_3_12154	59052322	0	59057268	010_0_11134	59057268	0
59052237	01A_0_12068	59052237	0		01A_4_24894	59052322	0	59057304	010_0_11134	59057304	0
	01A_1_12095	59052237	0	59056258	004_4_25109	59056258	1	59057319	010_1_11182	59057319	0
	01A_2_12123	59052237	0	59056259	004_4_25109	59056259	1		010_2_11218	59057319	0
	01A_3_12154	59052237	0	59056365	005_0_10769	59056365	0	59057550	01A_0_12068	59057550	0
	01A_4_24894	59052237	0		005_1_10807	59056365	0		01A_1_12095	59057550	0
59052238	01A_0_12068	59052238	0		005_2_10845	59056365	0		01A_2_12123	59057550	0



SPARE PARTS INSTANCE INDEX

Code	Parts Table	Pos.	Q.ty
59057550	01A_3_12154	59057550	0
	01A_4_24894	59057550	0
59057556	01A_0_12068	59057556	0
	01A_1_12095	59057556	0
	01A_2_12123	59057556	0
	01A_3_12154	59057556	0
	01A_4_24894	59057556	0
	10A_2_12281	59057556	0
59247884	003_0_10557	59247884	0
	003_1_10576	59247884	0
	003_2_10596	59247884	0
	003_3_25078	59247884	1
	003_4_27606	59247884	1
	003_5_33490	59247884	1
59247924	003_3_25078	59247924	1
	003_4_27606	59247924	1
	003_5_33490	59247924	1
59247971	003_0_10557	59247971	0
	003_1_10576	59247971	0
	003_2_10596	59247971	0
	003_3_25078	59247971	1
	003_4_27606	59247971	1
	003_5_33490	59247971	1
59256252	003_0_10557	59256252	0
	003_1_10576	59256252	0
59256253	003_3_25078	59256253	1
59256255	003_5_33490	59256255	1
59256265	003_2_10596	59256265	0
59256275	003_4_27606	59256275	1
	003_5_33490	59256275	1
59256279	003_4_27606	59256279	1
	003_5_33490	59256279	1
59256280	003_5_33490	59256280	1
59256999	10A_4_63871	59256999	1

Code	Parts Table	Pos.	Q.ty
59257151	012_5_32832	59257151	1
	012_6_64016	59257151	1
59257409	10A_4_63871	59257409	1
92480703	015_0_11945	92480703	0
	015_1_11971	92480703	0
	015_2_11997	92480703	0
	015_3_64117	92480703	1
92480718	015_0_11945	92480718	0
	015_1_11971	92480718	0
	015_2_11997	92480718	0
	015_3_64117	92480718	1
92480719	015_0_11945	92480719	0
	015_1_11971	92480719	0
	015_2_11997	92480719	0
	015_3_64117	92480719	1
92480720	015_0_11945	92480720	0
	015_1_11971	92480720	0
	015_2_11997	92480720	0
	015_3_64117	92480720	1
92480721	015_0_11945	92480721	0
	015_1_11971	92480721	0
	015_2_11997	92480721	0
	015_3_64117	92480721	1
92480757	015_0_11945	92480757	0
	015_1_11971	92480757	0
	015_2_11997	92480757	0
	015_3_64117	92480757	1
92480758	015_0_11945	92480758	0
	015_1_11971	92480758	0
	015_2_11997	92480758	0
	015_3_64117	92480758	1
92480836	015_0_11945	92480836	0
	015_1_11971	92480836	0
	015_2_11997	92480836	0

Code	Parts Table	Pos.	Q.ty
92480836	015_3_64117	92480836	1
F0300002174	010_0_11134	F0300002	0
F0305017120	010_0_11134	F0305017	0
F0305017125	010_0_11134	F0305017	0
F0814732000	010_0_11134	F0814732	0
F0828468050	010_0_11134	F0828468	0
F0831148000	010_0_11134	F0831148	0
F0831193010	010_2_11218	F0831193	0
F0831195040	010_0_11134	F0831195	0
F0837554000	010_0_11134	F0837554	0
F0864067020	010_0_11134	F0864067	0